

Engineering Drawing Notes – ME170

UNIT 8

Part C – Geometric Dimensioning & Tolerancing

Geometric dimensioning and tolerancing is a simplified method of dimensioning and tolerancing machined parts. Before this method was developed, long and often confusing notes were used to describe part features. Now, with geometric dimensioning and tolerancing, these complicated notes are replaced with easy-to-read symbols. In addition to showing the size and location of part features, this method also shows exactly how far part features can vary from true form and still function as intended.

Geometric dimensioning and tolerancing is normally used to control three part characteristics: form, location, and runout. A series of standard symbols indicates each variation. Almost any geometric form can easily be controlled with geometric dimensioning and tolerancing. The first step in mastering this dimensional form is to learn the terms and elements and how they are used.

TERMS AND SYMBOLS

The heart of the geometric dimensioning and tolerancing system is the proper interpretation of each symbol. Although you do not need to memorize these symbols, you should be able to identify each symbol and its correct meaning.

FEATURE CONTROL SYMBOL

The feature control symbol (Figure 8-1) lists the required tolerance data. This symbol is a frame that contains the geometric characteristic symbol, datum references, and tolerance value. The exact size and entries of the feature control symbol are determined by the part features that require control.

Geometric characteristic symbols show the characteristic that is to be controlled. Each of these symbols has a specific meaning and application, as shown in Figure 8-2.

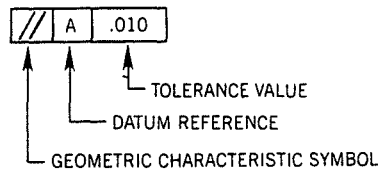

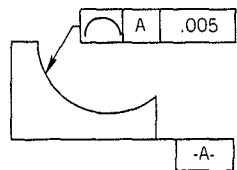
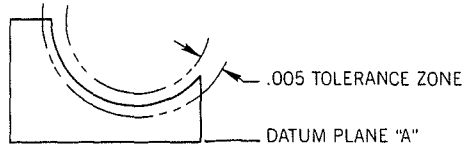
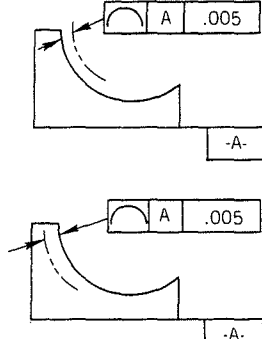
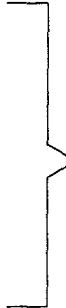


Figure 8-1 Feature control symbol.

GEOMETRIC CHARACTERISTIC	APPLICATION	INTERPRETATION
<p>—</p> <p>STRAIGHTNESS</p>		
<p>▭</p> <p>FLATNESS</p>		
<p>○</p> <p>ROUNDNESS</p>		
<p>⊘</p> <p>CYLINDRICITY</p>		

Figure 8-2 Geometric characteristic symbols.

GEOMETRIC CHARACTERISTIC	APPLICATION	INTERPRETATION
 <p>PROFILE OF A LINE</p>	 <p>BILATERAL</p>	 <p>.005 TOLERANCE ZONE DATUM PLANE "A"</p> <p>EACH ELEMENT OF THE LINE MUST LIE WITHIN A <u>BILATERAL</u> TOLERANCE ZONE CONSISTING OF TWO PARALLEL PLANES EQUALLY DISPOSED ABOUT THE TRUE PROFILE, RELATIVE TO THE DATUM PLANE AND .005" APART</p>
	 <p>UNILATERAL</p>	 <p>EACH ELEMENT OF THE LINE MUST LIE WITHIN A <u>UNILATERAL</u> TOLERANCE ZONE CONSISTING OF TWO PARALLEL PLANES DISPOSED ON EITHER SIDE OF THE TRUE PROFILE AS INDICATED BY THE FEATURE CONTROL SYMBOL, RELATIVE TO THE DATUM PLANE AND .005" APART</p>


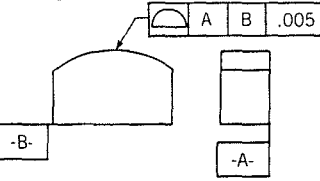
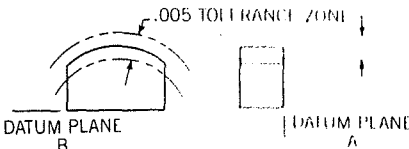
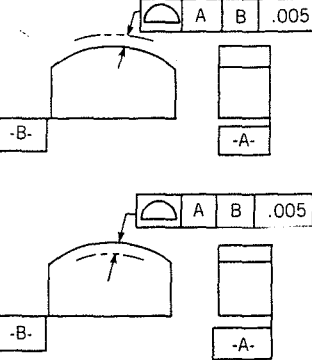


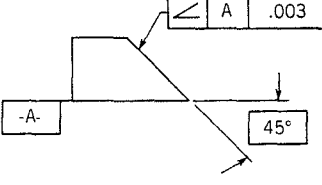
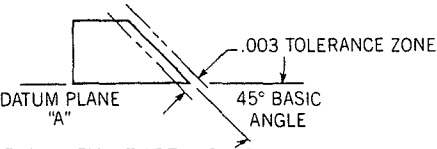

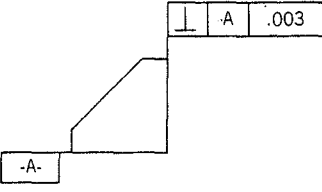
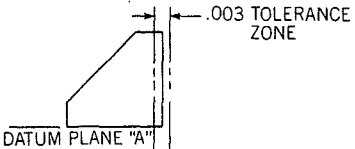

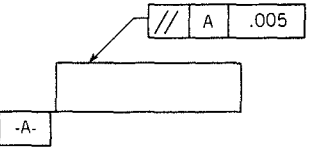
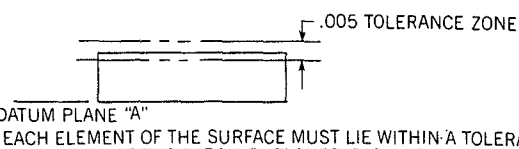

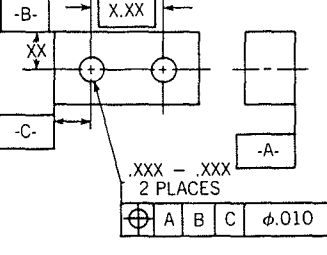
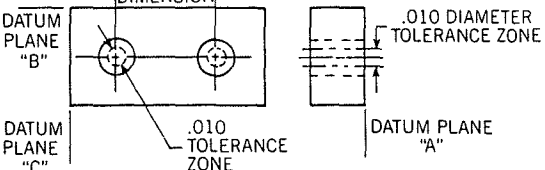

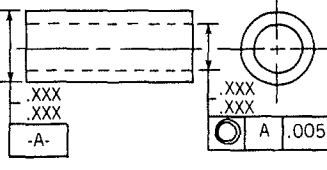
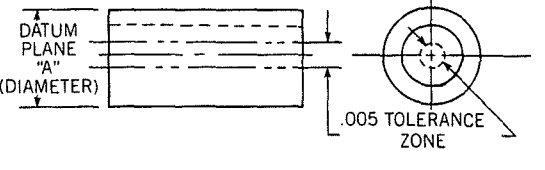
GEOMETRIC CHARACTERISTIC	APPLICATION	INTERPRETATION
 <p>PROFILE OF A SURFACE</p>	 <p>BILATERAL</p>	 <p>.005 TOLERANCE ZONE DATUM PLANE B DATUM PLANE A</p> <p>EACH ELEMENT OF THE SURFACE MUST LIE WITHIN A <u>BILATERAL</u> TOLERANCE ZONE CONSISTING OF TWO PARALLEL PLANES EQUALLY DISPOSED ABOUT THE TRUE SURFACE, RELATIVE TO THE DATUM PLANE AND .005" APART</p>
	 <p>UNILATERAL</p>	 <p>EACH ELEMENT OF THE SURFACE MUST LIE WITHIN A <u>UNILATERAL</u> TOLERANCE ZONE CONSISTING OF TWO PARALLEL PLANES DISPOSED ON EITHER SIDE OF THE TRUE PROFILE AS INDICATED BY THE FEATURE CONTROL SYMBOL, RELATIVE TO THE DATUM PLANE AND .005" APART</p>

Figure 8-2 (continued)

GEOMETRIC CHARACTERISTIC	APPLICATION	INTERPRETATION
 <p>ANGULARITY</p>		 <p> .003 TOLERANCE ZONE DATUM PLANE "A" 45° BASIC ANGLE </p> <p>EACH ELEMENT OF THE SURFACE MUST LIE WITHIN A TOLERANCE ZONE CONSISTING OF TWO PARALLEL PLANES INCLINED TO THE BASIC ANGLE, WITH REFERENCE TO THE DATUM PLANE, AND .003" APART</p>
 <p>PERPENDICULARITY</p>		 <p> .003 TOLERANCE ZONE DATUM PLANE "A" </p> <p>EACH ELEMENT OF THE SURFACE MUST LIE WITHIN A TOLERANCE ZONE CONSISTING OF TWO PARALLEL PLANES, PERPENDICULAR TO THE DATUM PLANE, AND .003" APART</p>
 <p>PARALLELISM</p>		 <p> .005 TOLERANCE ZONE DATUM PLANE "A" </p> <p>EACH ELEMENT OF THE SURFACE MUST LIE WITHIN A TOLERANCE ZONE CONSISTING OF TWO PARALLEL PLANES, PARALLEL TO THE DATUM PLANE, AND .005" APART</p>

GEOMETRIC CHARACTERISTIC	APPLICATION	INTERPRETATION
 <p>POSITION</p>		 <p> BASIC DIMENSION DATUM PLANE "B" DATUM PLANE "C" .010 TOLERANCE ZONE .010 DIAMETER TOLERANCE ZONE DATUM PLANE "A" </p> <p>HOLE CENTERS MUST LIE WITHIN A CYLINDRICAL TOLERANCE ZONE .010 IN DIAMETER, EQUALLY DISPOSED ABOUT THE CENTER LINES, RELATIVE TO THE BASIC DIMENSION AND DATUM PLANES</p>
 <p>CONCENTRICITY</p>		 <p> DATUM PLANE "A" (DIAMETER) .005 TOLERANCE ZONE </p> <p>HOLE CENTERLINE MUST LIE WITHIN A CYLINDRICAL TOLERANCE ZONE .005" IN DIAMETER, EQUALLY DISPOSED ABOUT THE CENTER LINE, RELATIVE TO THE DATUM PLANE (OUTSIDE DIAMETER)</p>


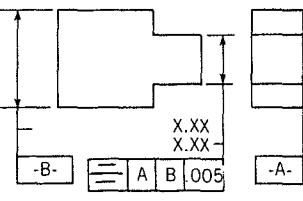
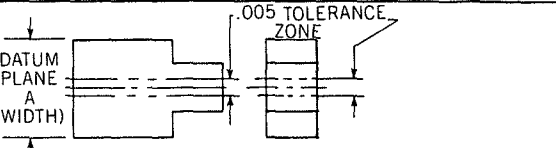

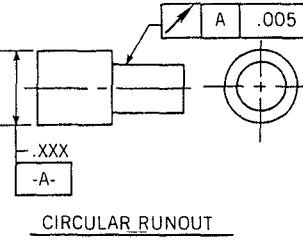
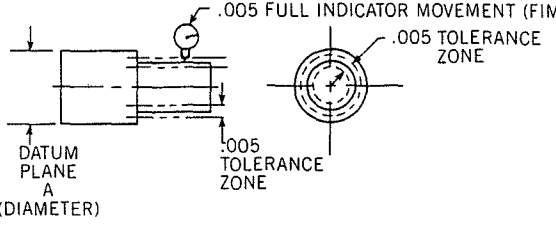

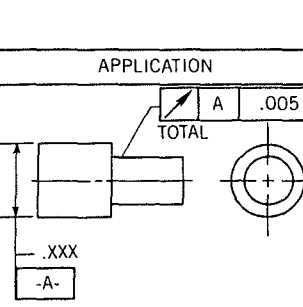
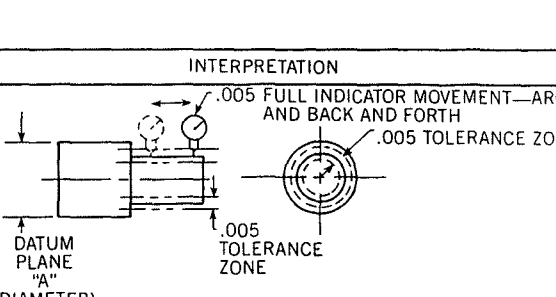
GEOEMTRIC CHARACTERISTIC	APPLICATION	INTERPRETATION
 SYMMETRY		 CENTERLINE OF PROJECTION MUST LIE WITHIN A TOLERANCE ZONE CONSISTING OF TWO PARALLEL PLANES .005 APART RELATIVE TO THE DATUM PLANES AND PART CENTER LINE
 RUNOUT CIRCULAR RUNOUT	 WHEN NO NOTATION OR WHEN THE ABBREVIATION "CIRC" IS USED BELOW THE FEATURE CONTROL SYMBOL CIRCULAR RUNOUT IS INDICATED	 EACH ELEMENT OF THE PROJECTION MUST BE LOCATED SO AN INDICATOR POSITIONED AS SHOWN WILL MOVE NO MORE THAN .005" WHEN THE PART IS REMOVED ON DATUM A
 RUNOUT (THE SYMBOL MAY ALSO BE USED TO SHOW TOTAL RUNOUT) TOTAL RUNOUT	 TOTAL RUNOUT IS INDICATED WHEN THE WORD "TOTAL" APPEARS BELOW THE FEATURE CONTROL SYMBOL	 EACH ELEMENT OF THE PROJECTION MUST BE LOCATED SO AN INDICATOR, POSITIONED AS SHOWN, WILL MOVE NO MORE THAN .005" WHEN THE PART IS REVOLVED ON DATUM A AND THE INDICATOR IS MOVED BACK AND FORTH

Figure 8-2 (continued)

Datum references are the letter values that identify a specific datum surface on the part. A datum is a line, surface, edge, or a point on the part that is used as a reference or point of origin for dimensions. The letter value shown in the feature control symbol refers to the specific datum shown with a datum identification symbol. As shown in Figure 8-3, the datum reference in the feature control symbol means the detail must be held parallel to the datum surface shown with the datum identification symbol. When more than one letter is used as a datum reference (Figure 8-4), the first letter indicates the primary datum, the second letter indicates the secondary datum, and the tertiary datum is shown with the third letter. Figure 8-5 shows how these three datums are

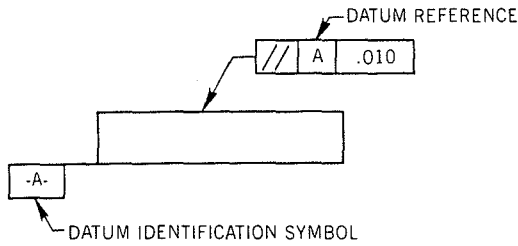


Figure 8-3 Application of datum reference and datum identification symbols.

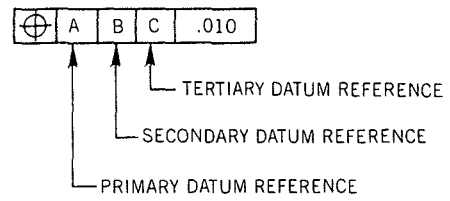


Figure 8-4 Primary, secondary, and tertiary datums.

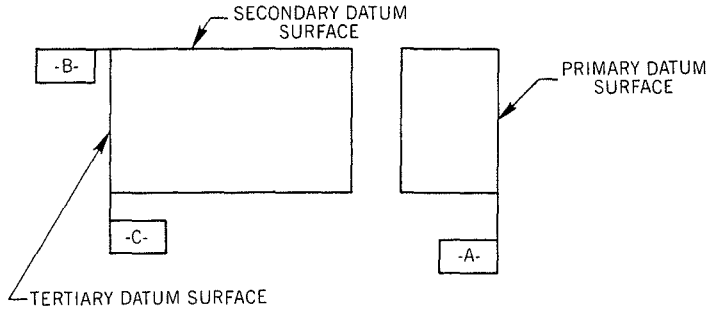


Figure 8-5 Relating datums to an actual part.

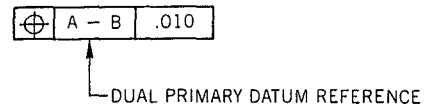


Figure 8-6 Dual primary datums.

related to a single part. In cases where a part has two datum surfaces that are primary datums, the datum references will have a dash between them (Figure 8-6).

Tolerance values show how much the part can vary from the dimensioned size and still pass inspection. Remember this is a *total* amount, not a plus or minus value.

SUPPLEMENTARY SYMBOLS

Supplementary symbols define and further clarify the meaning of the other entries in the feature control symbol.

Maximum material condition, or MMC, is the size of a part when it has the most material allowed by the tolerance. As shown in Figure 8-7, this condition means the largest size of an external feature and the smallest size of an internal feature. The key point to remember here is *most material*. The opposite condition from the MMC is the *least material condition*, or LMC. Here the part has its least material: the smallest size of an external feature or the largest

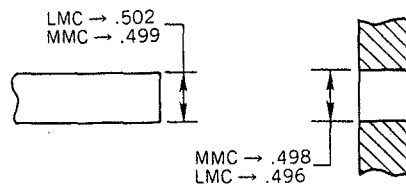


Figure 8-7 Maximum and least material conditions.

size of an internal feature. The key point to remember here is *least material*. Every part feature has both an MMC and an LMC.

The MMC modifier, indicated by a circled **(M)**, is used only for those parts that can vary in size. When the MMC modifier is applied to a tolerance value (Figure 8-8), it means that the tolerance shown only applies when the feature is at its maximum material size. As the size of the part feature departs from the MMC size, the tolerance value increases by the amount of variation. To illustrate how this occurs, refer to the chart shown in Figure 8-9. The size of the feature is $.500 \pm .003$, and the tolerance in the feature control symbol is $.002''$. The MMC size of the part is $.503''$, and the LMC size is $.497''$. As shown in the chart, the $.002''$ tolerance only applies at the $.503$ dimension. As the feature size departs from the MMC, the tolerance increases by the amount of variation.

The MMC modifier can also be applied to a datum reference if the reference is subject to a change in size. As shown in Figure 8-10, as the size of the datum varies from the MMC size, the tolerance values also vary by the amount of departure from the MMC. Only the MMC modifier is called out in the feature control symbol. The LMC is a reference value and has no modifier in the feature control symbol.

Regardless of feature size, or RFS, is a modifier indicating that the tolerance applies regardless of the size of the feature. Like the MMC modifier, the RFS modifier may be applied to either a feature size or a datum reference. Likewise, the RFS modifier, shown by a circled **(S)**, only applies to a feature or datum that can vary in size. The effect of the RFS modifier is shown in Figure 8-11.

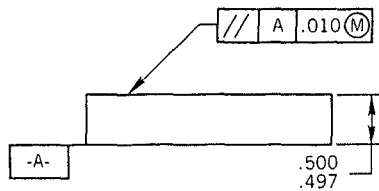
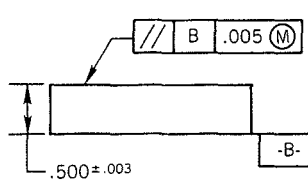
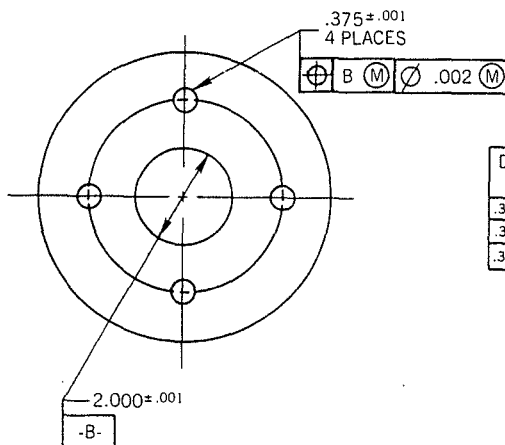


Figure 8-8 Applying an MMC modifier to a tolerance.



TOLERANCE	
DETAIL SIZE	ALLOWED
.503 MMC	.005
.502	.006
.501	.007
.500	.008
.499	.009
.498	.010
.497 LMC	.011

Figure 8-9 Interpreting the effect of MMC on a dimension.



DETAIL SIZE	DATUM B SIZE		
	1.999 MMC	2.000	2.001 LMC
.374 MMC	.002	.003	.004
.375	.003	.004	.005
.376 LMC	.004	.005	.006

Figure 8-10 Applying the MMC modifier to a datum and a tolerance.

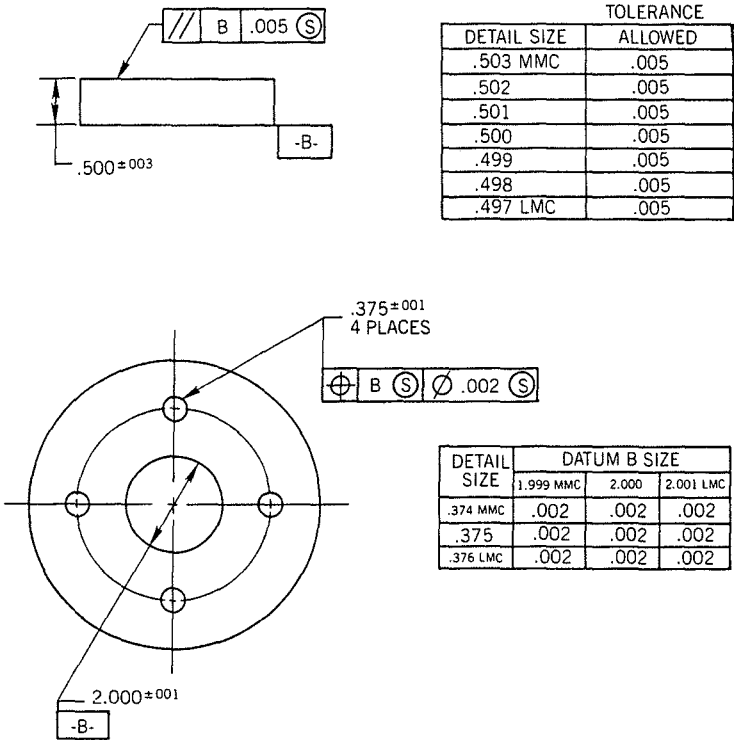


Figure 8-11 Interpreting the effect of RFS on a dimension and datum.

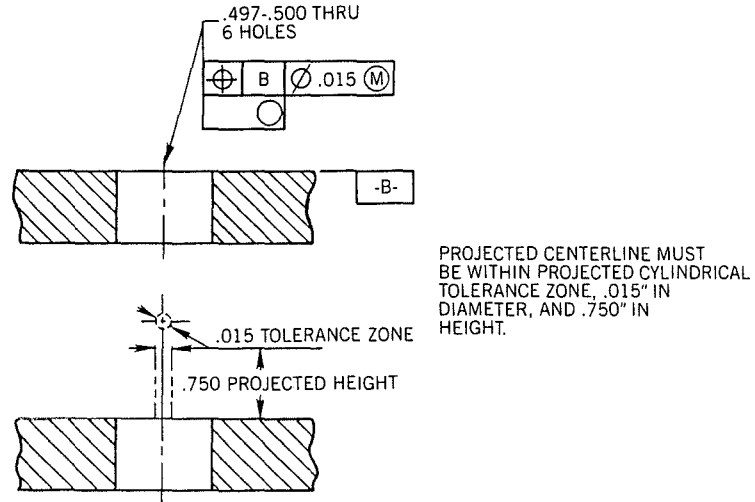


Figure 8-12 Projected tolerance zone modifier.

When the RFS modifier appears, the stated tolerance applies regardless of any variations in the part sizes.

Projected tolerance zone, shown with a circled (P), indicates that the tolerance zone is to be projected above the surface of the part (Figure 8-12). This modifier is normally positioned below the feature control symbol and is used for applications where mating parts must have aligned holes.

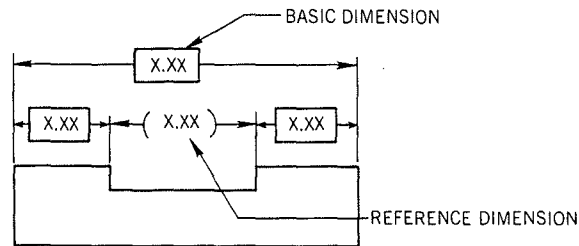


Figure 8-13 Basic dimension.

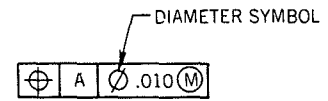


Figure 8-14 Diameter symbol used in a feature control symbol.

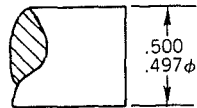


Figure 8-15 Diameter symbol used to abbreviate diameter.

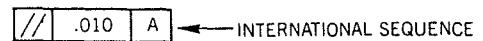


Figure 8-16 Usual and international sequence of tolerance data.

Basic and reference dimensions are shown on geometrically toleranced prints by a box or parenthesis. The box (Figure 8-13) is used to indicate a basic dimension. Basic dimensions are considered to be exact. The tolerance, if any, is applied to the basic dimension. Reference dimensions are for informational purposes only and are shown in parenthesis [()].

Diameter symbols show the tolerance value applied to a diameter. In feature control symbols, the diameter symbol is placed before the tolerance value (Figure 8-14). This symbol may also be used to indicate a diameter abbreviation (Figure 8-15).

SEQUENCE OF TOLERANCE DATA

The tolerance data in a feature control symbol may be placed in either the usual or the international sequence (Figure 8-16). The only difference between these two symbols is the order of the datum reference and the tolerance value. The usual sequence places the datum reference first and the tolerance data last. The international sequence simply reverses the position of these two values.