

ECE 463 Lab 5: Modulation II : ASK, FSK

1. Introduction

In this lab, we will implement two non-coherent modulations: Amplitude Shift Keying (ASK) and Frequency Shift Keying (FSK). In ASK, the message is represented in the amplitude of a carrier signal. The amplitude of the carrier signal varies with the message signal, keeping the frequency and the phase constant. On-Off Keying is the simplest form of ASK modulation representing the binary message at the presence (one) and absence (zero) of a carrier signal. In FSK, the message is transmitted through discrete frequency changes of a carrier signal. In general, a standard FSK signal does not have continuous phase, as the modulate signal instantaneously switches between two different frequencies. In the lab, we will implement FSK with continuous phase that avoids the wideband frequency components from the discontinuity of phase.

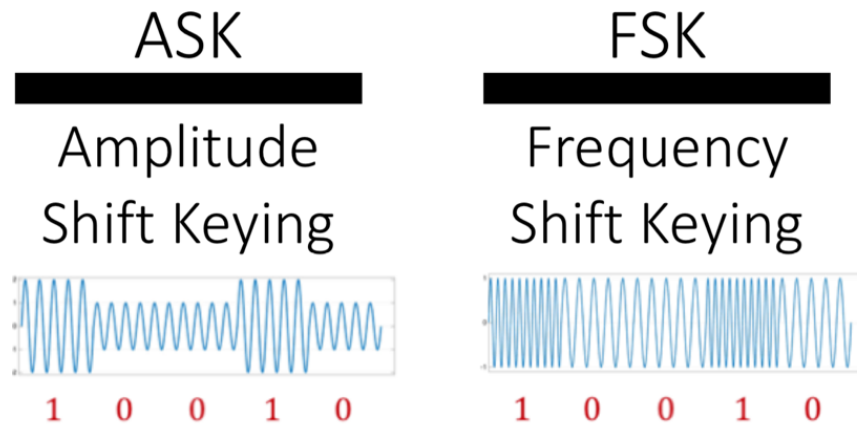

1.1. Contents

1. Introduction
2. Amplitude Shift Keying
3. Frequency Shift Keying

1.2. Report

Submit the answers, figures and the discussions on all the questions. The report is due as a hard copy at the beginning of the next lab.

2. ASK: On-Off Keying (OOK)

2.1. Transmitter

Start by loading “TxDBPSK.gvi” and rename it as “TxOOK.gvi”. In this section, we will build a transmitter that performs On-Off Keying (OOK) modulation. The data is conveyed in the amplitude of the carrier signal (e.g. “1” for amplitude 1 and “0” for amplitude 0). The OOK modulated signal has a similar form with the amplitude modulation as

$$y(t) = \frac{1}{2}(1 + m(t)) \cdot A \cdot \cos(2\pi f_c t)$$

where $m(t)$ is the pulse-shaped symbols (between -1 and 1), A is the amplitude of the carrier, and f_c is the carrier frequency.

Set the default parameter values in the panel:

- Carrier frequency: 900.1MHz
- IQ rate: 400k
- Gain: 0
- Active antenna: TX1
- Message length: 1000
- Symbol rate: 10k

1. Reuse the basic transmitter chains (e.g. bit-to-symbol, adding training sequence, pulse shaping, convolution, etc). Change the modulation type of the pulse shaping to “ASK”. (Do not use or bypass differential encoding.)
2. Implement OOK modulation in the hidden box below.



2.2.Receiver

Start by loading “RxDBPSK.gvi” and rename it as “RxOOK.gvi”. In this section, we will build a receiver that performs On-Off Keying (OOK) modulation.

Set the default parameter values in the panel:

- Carrier frequency: 900MHz (make sure 100kHz offset to Tx)
 - IQ rate: 400k
 - Gain: 0
 - Active antenna: RX2
 - Message length: 1000
 - Symbol rate: 10k
1. Reuse the basic receiver chains (e.g. matched filtering, pulse alignment, frame sync, symbol-to-bit, BER, constellation, etc). Change the modulation type of the pulse shaping to “ASK”. (Do not use or bypass differential decoding.)
 2. Implement OOK demodulation. Use bandpass filter to remove any unwanted tones (the desired received signal at 100kHz). Implement a rectifier in the blank diagram.

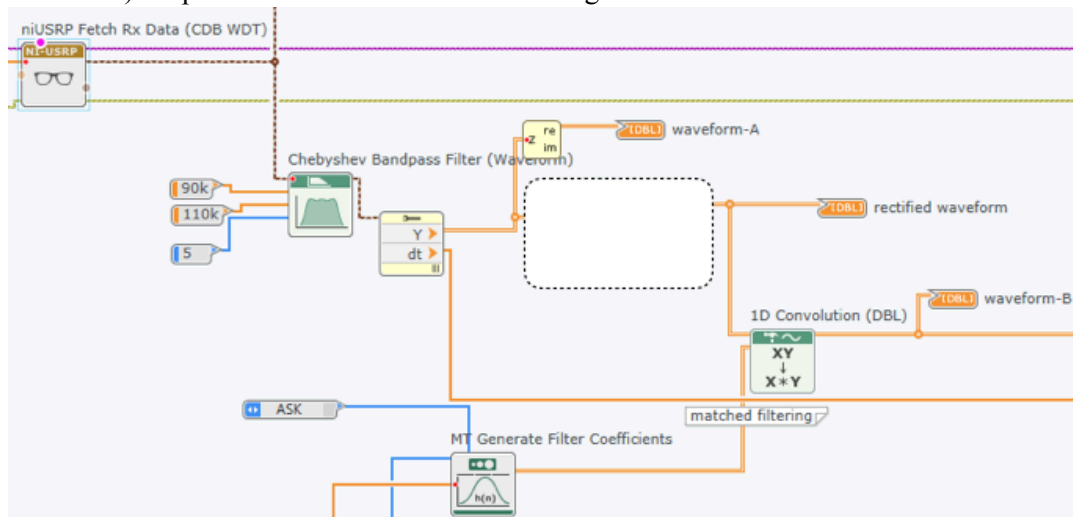

Figure 1.

3. Use a right threshold value for the frame-sync block.
4. Verify if you can decode the bits correctly and achieve correct constellation and BER.

2.3. Questions

- 2.3.1. In Figure 1, what waveforms do you expect to see in “waveform-A”, “rectified waveform”, and “waveform-B”? Plot the results and explain how you see such waveforms.
- 2.3.2. If you want to implement Amplitude Shift Keying (ASK) instead of OOK, what do you modify and add? (You don't have to implement in diagram.)

3. Frequency Shift Keying (FSK)

3.1. Transmitter

Start with “TxASK.gvi” and rename it as “TxFSK.gvi”. In this section, we will build a transmitter that performs binary Frequency Shift Keying (FSK) modulation. The data is conveyed in the frequency of the carrier signal. The Continuous-phaseFSK modulated signal has a similar form with the frequency modulation as

$$y(t) = A \cdot \cos\left(2\pi f_c t + 2\pi \Delta f \int_0^t m(\tau) d\tau\right)$$

where Δf is the peak frequency deviation, $m(t)$ is the pulse-shaped symbols (between -1 and 1), A is the amplitude of the carrier, and f_c is the carrier frequency.

Set the default parameter values in the panel:

- Carrier frequency: 1GHz
- IQ rate: 400k
- Gain: 0
- Active antenna: TX1
- Message length: 1000
- Symbol rate: 10k
- Enabled Channels: 0

1. Reuse the basic transmitter chains (e.g. bit-to-symbol, adding training sequence, pulse shaping, convolution, etc). Change the modulation type of the pulse shaping to “FSK”.
2. (Frequency Modulation) Complete the following diagram in your VI to implement FSK modulation. See the FSK equation. The integration of $m(t)$ is already implemented by IIR filter.

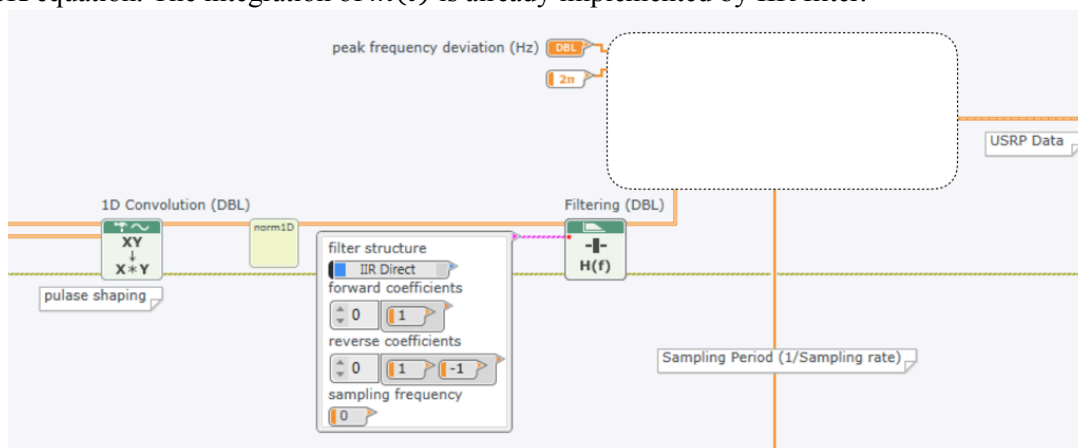

Figure 2.

3. Use the peak frequency deviation as 20kHz.

3.2. Receiver

Start with “RxBPSK.gvi” and rename it as “RxFSK.gvi”. In this section, we will build a receiver that performs binary Frequency Shift Keying (FSK) demodulation.

Set the default parameter values in the panel:

- Carrier frequency: 1G
- IQ rate: 400k
- Gain: 0
- Active antenna: RX2
- Message length: 1000
- Symbol rate: 10k

1. Reuse the basic receiver chains (e.g. matched filtering, pulse alignment, frame sync, symbol-to-bit, BER, constellation, etc).
2. (Frequency Demodulation) Implement the following diagram in your VI for frequency demodulation. (Note that there is no reverse coefficient.)

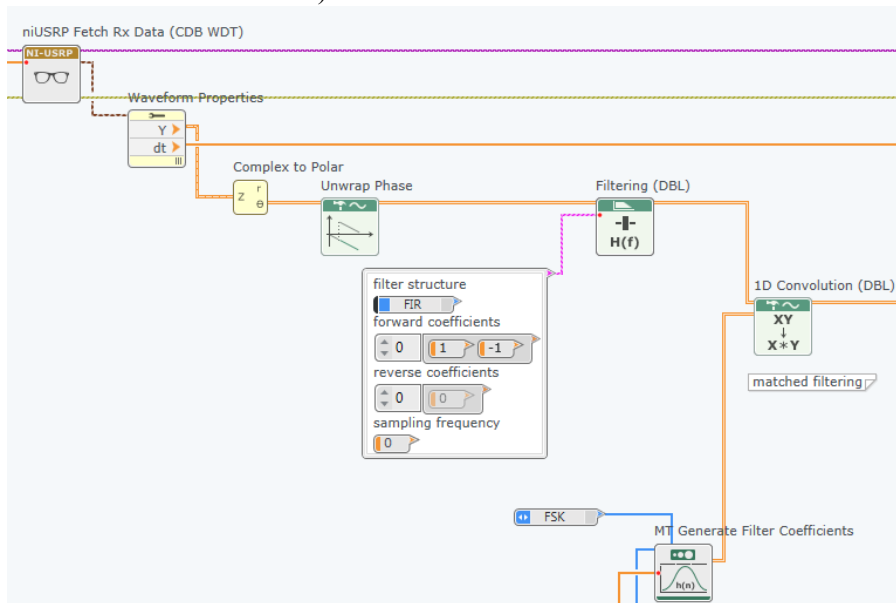

Figure 3.

3. Use a right threshold value for the frame-sync block.
4. Verify if you can decode the bits correctly and achieve correct constellation and BER.

3.3. Questions

- 3.3.1. Plot the spectrum of transmitted signal at a couple of different peak frequency deviations. Compare their bandwidth with the theoretical FSK bandwidth.
- 3.3.2. Reduce the peak frequency deviation (Δf) until the decoding fails. Compare and discuss the result with the theoretical Δf .
- 3.3.3. Explain how Figure 2 and 3 perform frequency modulation and demodulation.