

ECE 445

SENIOR DESIGN LABORATORY

FINAL REPORT

Onboard Edge Computing for High-Resolution FMCW SAR on An Integrated UAV Platform

Team #12

CHENXIAO WANG
(cw95@illinois.edu)

GISELLE LIM JEAY JEE
(gjee2@illinois.edu)

VICTORIA LIM JEAY JIA
(vljia2@illinois.edu)

YINFEI MA
(yinfeim2@illinois.edu)

TA: Weibo Yuan

Instructor: Shurun Tan

May 2026

Abstract

This project implements an unmanned aerial vehicle (UAV)-mounted frequency-modulated continuous-wave synthetic aperture radar (FMCW SAR) system with onboard edge computing for real-time radar image generation. The system integrates an FMCW radar front end, signal acquisition hardware, an NVIDIA Jetson Orin Nano processing platform, UAV telemetry/control interfaces, and a redesigned 3D-printed enclosure for mechanical mounting and wiring access. Radar data is digitized, processed onboard using Fourier-transform-based SAR imaging methods, and prepared for visualization through the UAV control interface. The final design focuses on improving system integration, reducing reliance on offline post-processing, and supporting low-latency SAR image formation during UAV operation. Verification includes subsystem-level testing of signal acquisition, processing latency, communication, mechanical fit, and system integration. The completed system demonstrates progress toward a practical UAV-borne SAR platform capable of onboard processing and real-time situational awareness.

Contents

1	Introduction	1
1.1	Problem Background	1
1.2	Project Objectives	2
1.3	System Overview	2
1.4	High-Level Requirements	3
2	System Design	4
2.1	Overall System Architecture	4
2.2	RF Subsystem	5
2.2.1	RF Circuit	6
2.2.2	Antenna Pair	6
2.3	Onboard Processing Subsystem	6
2.4	Communication and Control Subsystem	7
2.5	Mechanical System Design	9
2.6	PCB Design	11
2.6.1	Wave Generator	11
2.6.2	Signal Amplifier	12
2.7	Power Supply	12
2.7.1	Project Schedule	13
3	Testing and Verification	14
3.1	PCB Testing	14
3.2	RF Testing	15
3.3	Communication and Telemetry Testing	15
3.4	SAR Processing Verification	16
3.5	Mechanical Verification	17
3.6	Integration Results	17
3.7	System Limitations and Tradeoffs	18
3.8	Summary	18
4	Cost	19
4.1	Parts	19
4.2	Labor	19
5	Conclusion	20
5.1	Accomplishments and Uncertainties	20
5.2	Ethical Considerations	20
5.3	Future Work	21
	References	22
	Appendix A Mechanical Design Appendix	23
	Appendix B Requirement and Verification Tables	24

1 Introduction

Synthetic aperture radar (SAR) systems mounted on unmanned aerial vehicles (UAVs) have become increasingly useful for applications such as terrain mapping, infrastructure inspection, environmental monitoring, and disaster response. Compared to optical imaging systems, SAR systems are capable of operating under poor lighting and adverse weather conditions because radar sensing does not rely on visible light. Among different SAR approaches, frequency-modulated continuous-wave synthetic aperture radar (FMCW SAR) provides several advantages for UAV deployment, including lower power consumption, compact hardware requirements, and reduced system weight [1].

Previous UAV-mounted FMCW SAR implementations within this project area demonstrated the feasibility of integrating radar sensing systems with commercial UAV platforms. However, earlier systems relied heavily on offline processing for SAR image reconstruction and encountered several practical limitations during testing, including unstable hardware integration, sensitivity to UAV motion disturbances, wiring constraints, and inconsistent image quality [2]. These limitations reduced the practicality of the system for real-time situational awareness and rapid field deployment.

This project addresses these limitations through the development of an integrated UAV-borne FMCW SAR platform with edge computing capabilities onboard. The system combines radar sensing hardware, signal acquisition circuitry, GPU-accelerated processing onboard, communication interfaces, and a redesigned mechanical enclosure into a unified platform capable of performing SAR image generation directly onboard the UAV. By moving SAR image reconstruction from offline post-processing to embedded real-time computation, the system reduces processing latency and improves operational usability during flight missions.

1.1 Problem Background

Traditional UAV-based SAR systems commonly depend on post-flight processing because SAR image formation algorithms require significant computational resources [3]. This introduces delays between radar data acquisition and image generation, making the system less suitable for applications that require immediate environmental feedback. In addition, practical deployment introduces several engineering challenges involving payload integration, mechanical stability, cable routing, vibration tolerance, power delivery, and reliable communication between onboard devices and the UAV platform [4].

Earlier implementations also faced challenges related to image quality degradation caused by UAV motion and limited onboard computational performance. Mechanical integration constraints between the gimbal assembly, radar hardware, and the onboard computing platform further complicated deployment and maintenance. These issues motivated the redesign of both the hardware architecture and the computational pipeline.

1.2 Project Objectives

The primary objective of this project is to implement a UAV-mounted FMCW SAR system capable of performing real-time onboard SAR image reconstruction using an embedded edge computing platform. The project focuses on improving system integration, reducing processing latency, enhancing imaging reliability, and supporting practical UAV deployment.

Specific project objectives include:

- Integrate an FMCW radar sensing system with a UAV platform for airborne SAR data acquisition.
- Implement a signal acquisition pipeline capable of conditioning, digitizing, and transferring radar data to the onboard processor.
- Develop an onboard SAR processing pipeline using GPU-accelerated computation on the NVIDIA Jetson Orin Nano platform.
- Improve mechanical integration through a redesigned 3D-printed enclosure supporting the radar hardware, onboard processor, and wiring interfaces.
- Support communication between onboard subsystems and the UAV control interface for telemetry exchange and visualization.

1.3 System Overview

The UAV-mounted FMCW SAR system developed in this project integrates radar sensing hardware, onboard edge computing, signal acquisition circuitry, communication interfaces, and a custom mechanical payload structure into a unified airborne sensing platform. The overall system workflow is illustrated in Figure 1.

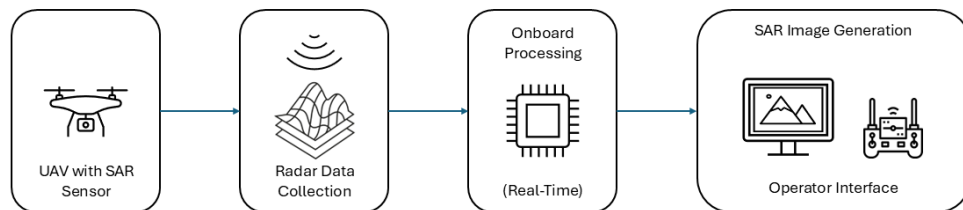

Figure 1: Conceptual overview of real-time SAR imaging with onboard processing

During operation, the FMCW radar front-end transmits radar signals toward the surrounding environment and receives reflected radar echoes from nearby objects and terrain features. The received analog radar signals are conditioned and digitized before being transferred to the onboard processing subsystem.

The onboard processing subsystem is implemented using the NVIDIA Jetson Orin Nano embedded computing platform. This subsystem performs radar data acquisition, temporary data storage, SAR signal processing, and image reconstruction directly onboard the UAV platform. By integrating SAR image formation into the embedded processing pipeline, the system reduces dependence on offline post-processing and improves operational responsiveness during UAV operation.

Processed SAR images and telemetry data are transmitted through the communication and control subsystem to the operator interface for monitoring and visualization. Communication between the payload system and UAV platform is supported through the DJI Payload SDK (PSDK) interface and onboard communication hardware. To support subsystem integration, a custom 3D-printed enclosure and mounting structure were designed for the radar hardware, onboard processor, wiring interfaces, and compatibility with the UAV gimbal-supported payload structure.

The complete system architecture is divided into five major subsystems: the RF sensing subsystem, signal acquisition subsystem, onboard processing subsystem, communication and control subsystem, and the mechanical and power integration subsystem. The interaction between these subsystems is discussed in detail in Section 2.

1.4 High-Level Requirements

- The system shall process radar return signals while maintaining a minimum signal-to-noise ratio (SNR) of 5 dB.
- The system must be capable of generating two-dimensional SAR images with a meter-level resolution and sufficient contrast to distinguish basic scene features.
- The system must perform onboard processing and transmit SAR images to the ground controller with an end-to-end latency of no more than 5 seconds per frame.

2 System Design

2.1 Overall System Architecture

The overall system architecture was designed to support real-time FMCW SAR data acquisition, onboard SAR image reconstruction, subsystem communication, and stable UAV payload integration. Figure 2 illustrates the interaction between the major subsystems within the UAV-mounted SAR platform.

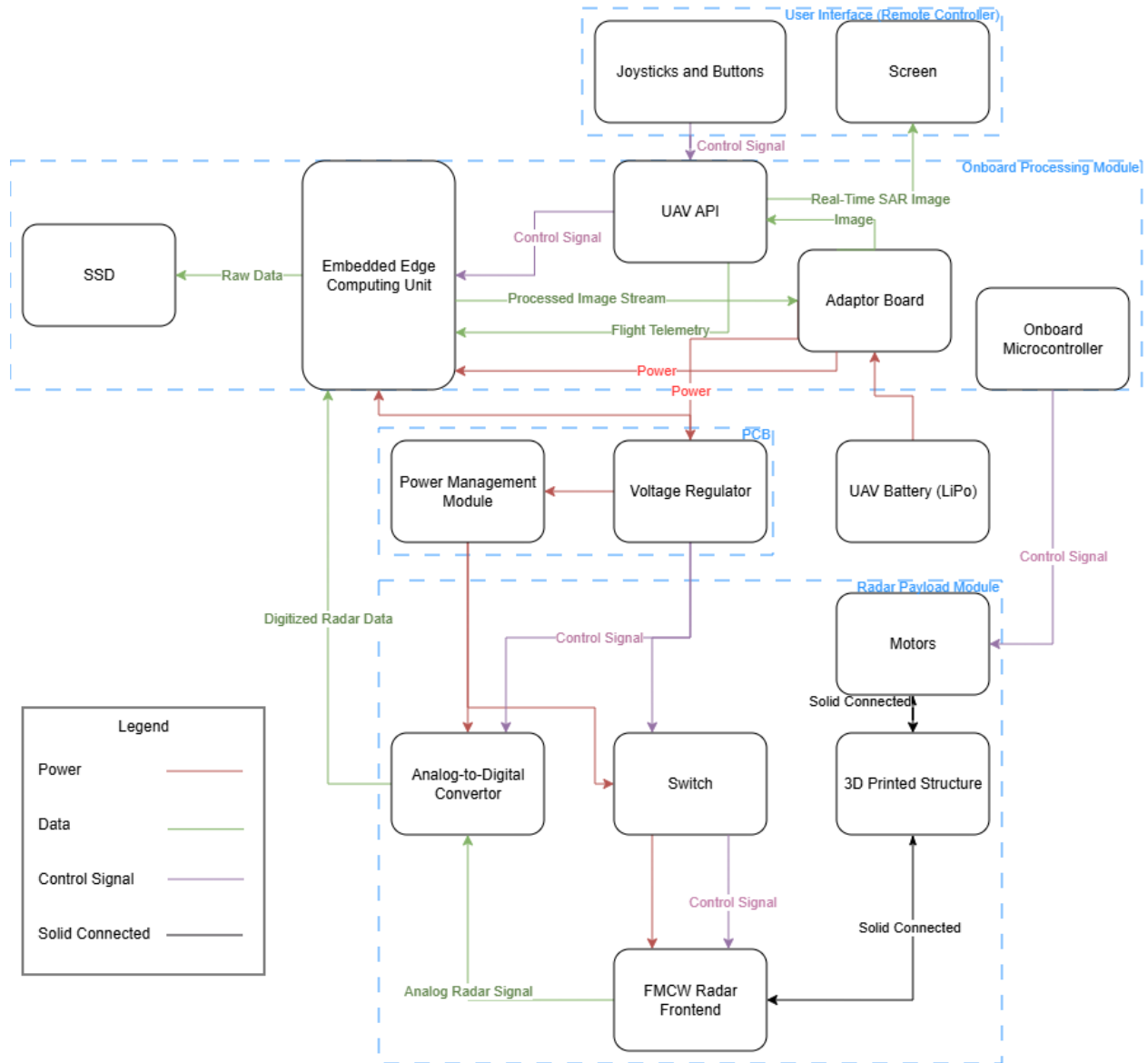

Figure 2: Overall block diagram of the UAV-mounted FMCW SAR system

The system integrates five primary subsystems: the RF sensing subsystem, signal acquisition subsystem, onboard processing subsystem, communication and control subsystem, and the mechanical and power integration subsystem. Together, these subsystems sup-

port radar sensing, onboard SAR processing, telemetry exchange, and image visualization during UAV operation.

The RF sensing subsystem generates and receives FMCW radar signals during flight operation. Reflected signals are conditioned and digitized before being transferred to the onboard processing subsystem.

The onboard processing subsystem, implemented using the NVIDIA Jetson Orin Nano platform [5], performs radar data acquisition, SAR signal processing, and image reconstruction directly onboard the UAV. Processed SAR images and telemetry data are transmitted to the operator interface for visualization.

Communication between the payload system and UAV platform is supported through the DJI Payload SDK (PSDK) interface and DJI X-Port connection [6]. Mechanical integration between the radar hardware, onboard processor, and UAV mounting structure was supported through a custom-designed 3D-printed enclosure.

Compared to earlier UAV-mounted FMCW SAR implementations, the completed architecture reduces reliance on offline SAR image reconstruction through GPU-accelerated onboard processing.

2.2 RF Subsystem

The RF subsystem is responsible for generating, transmitting, receiving, and down-converting the radar signal. It works as the front-end sensing part of the UAV-mounted FMCW SAR system. In this project, the RF subsystem is mainly divided into two parts: the RF circuit and the antenna pair. Figure 3 shows the implemented RF subsystem.

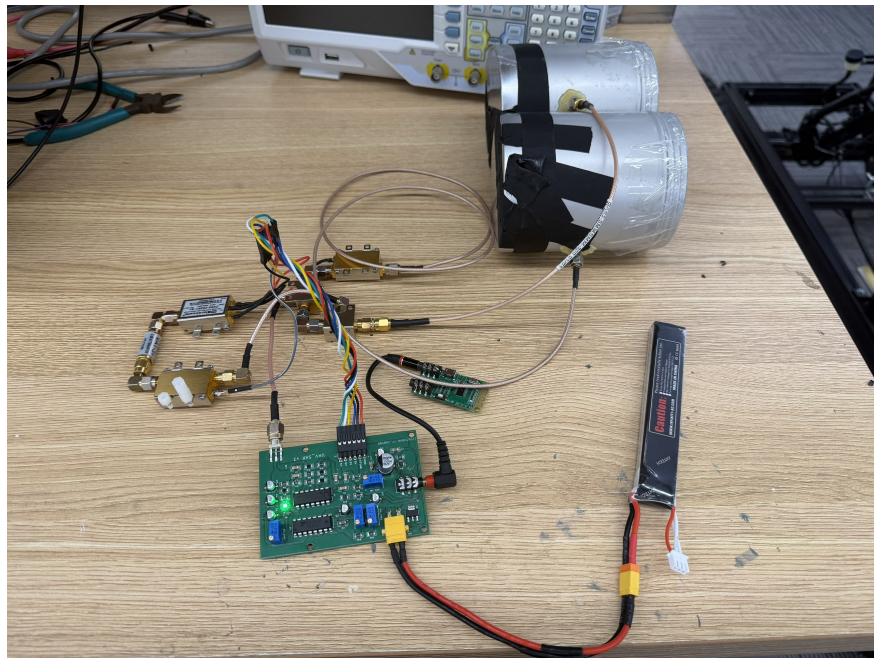

Figure 3: RF subsystem

2.2.1 RF Circuit

The RF circuit generates the FMCW radar signal and processes the received echo signal [1]. The triangular waveform generated by the PCB is used as the tuning signal for the voltage-controlled oscillator. The oscillator then produces a frequency-modulated RF signal for radar transmission.

After the RF signal is generated, it is amplified and divided into two paths. One path is sent to the transmitting antenna, while the other path is used as the reference signal for the mixer. The echo signal received by the receiving antenna is also sent to the mixer. By mixing the received signal with the reference signal, the RF circuit produces a low-frequency beat signal. This beat signal contains the target range information and is sent to the PCB signal amplifier for filtering and amplification.

Overall, the RF circuit converts the low-frequency control waveform into a high-frequency FMCW radar signal, and then converts the received radar echo back into a low-frequency signal that can be acquired and processed.

2.2.2 Antenna Pair

The antenna pair consists of two antennas with the same design. One antenna is used for transmission, and the other one is used for reception. The transmitting antenna radiates the FMCW signal toward the target area, while the receiving antenna collects the reflected echo signal from the environment.

The two antennas have identical structures because of the reciprocity principle of antennas. This means that the same antenna design can be used for both transmitting and receiving signals. During UAV flight, the antenna pair provides the physical interface between the RF circuit and the imaging scene. Its performance directly affects the received signal strength, system signal-to-noise ratio, and final SAR image quality.

2.3 Onboard Processing Subsystem

This system is a UAV-based synthetic aperture radar imaging pipeline designed to convert continuous radar returns into focused ground images. The radar signal is captured as a time-domain waveform, segmented into individual pulses using the trigger channel, and converted into complex range profiles. These range profiles represent the measured echoes from the scene at successive radar positions along the drone flight path, which are later combined to form a focused SAR image [7].

The imaging algorithm is Fast Factorized Backprojection, or FFBP. FFBP was selected because it preserves the main strength of backprojection: the ability to form images from non-ideal drone trajectories, while greatly reducing the computational cost. Instead of coherently summing every radar pulse into every image pixel in one large operation, FFBP recursively combines smaller subapertures and subimages. This divide-and-conquer structure allows the system to keep much of the image quality of conventional backprojection while making the computation more suitable for onboard processing.

The system is designed for deployment on an NVIDIA Jetson Orin Nano. The most expensive parts of the reconstruction are accelerated with CUDA through CuPy and custom GPU kernels. This allows range compression, phase compensation, interpolation, and coherent accumulation to be performed on the GPU, while the CPU handles signal acquisition, pulse detection, control logic, and data management. The result is a compact onboard SAR processor that can produce images much faster than a purely CPU-based implementation.

Figure 4 illustrates the main processing stages of the onboard SAR imaging pipeline.

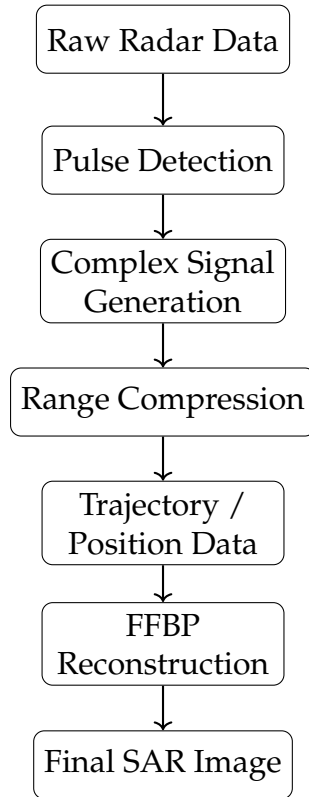

Figure 4: Schematic diagram for the SAR imaging algorithm

2.4 Communication and Control Subsystem

The communication and control system connects the custom FMCW SAR payload to the DJI Matrice 300 RTK through both hardware and software interfaces. The hardware interface consists of the DJI X-Port gimbal and an adapter board. The X-Port provides the mechanical and gimballed payload connection to the aircraft, while the adapter board exposes the required power and communication connections to the SAR electronics. The payload computer acts as the central bridge between the DJI platform and the FMCW SAR hardware.

On the software side, the payload computer runs the DJI Payload SDK (PSDK) libraries [6] together with the SAR acquisition, data recording, preview generation, and radar process-

ing software. The payload computer therefore functions as both a communication end-point and the onboard radar data processor. It receives control commands from DJI Pilot or a custom mobile application, controls the FMCW radar front-end, stores raw radar data locally, processes the recorded data into focused SAR images, and transfers the final image results back to the DJI-side interface.

The control path is organized around high-level mission commands such as bring-up, start recording and processing, and push final result. These commands are received by the PSDK application running on the payload computer and forwarded to the internal payload controller, which triggers the corresponding SAR software operation. For example, the bring-up command initializes the radar front-end and local storage, while the recording command starts radar acquisition and metadata logging. During operation, the payload computer processes the recorded radar data into focused SAR images and streams the results back to the drone.

After power is supplied through the X-Port and adapter board, the payload computer boots and initializes the PSDK application. Once the DJI-side connection is established, the payload enters a standby state. During recording, the payload computer controls the radar front-end and stores raw radar data locally. During processing, it reads the recorded radar data, generates focused SAR images, continuously transmits preview streams to the UAV, and sends the final SAR image results to the operator interface.

Figure 5 illustrates the control path, real-time preview flow, and SAR image flow within the onboard processing system.

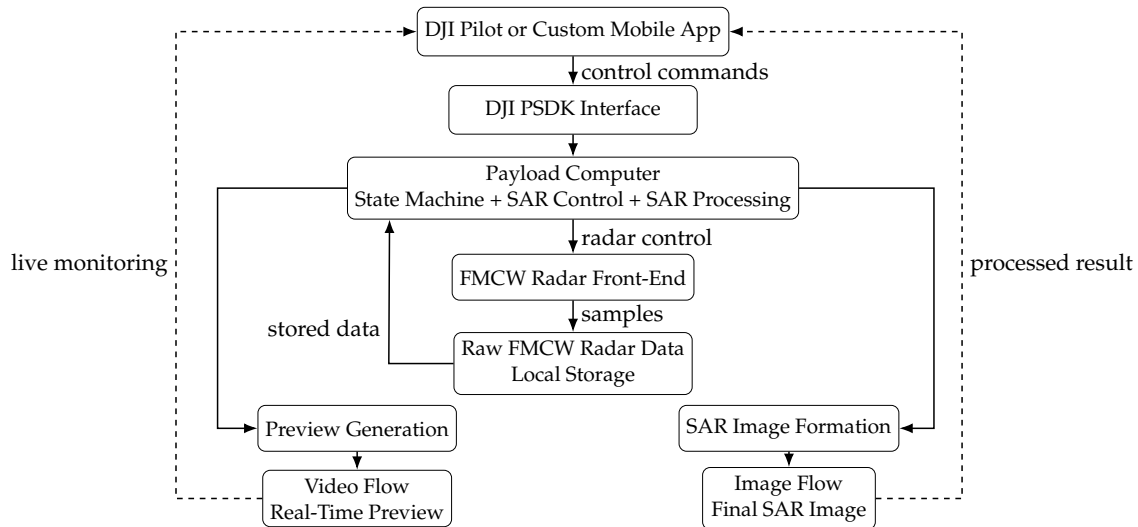

Figure 5: Control path, real-time preview flow, and SAR image flow

The communication system is separated into two data paths because the real-time preview and final SAR image have different requirements. The first path is the video flow, which transports a real-time radar preview to the DJI Pilot application. Since the payload is an FMCW SAR rather than an optical camera, the stream is a rendered representation of radar data optimized for low latency and operator awareness.

The second path is the payload image flow, which transfers the final SAR image results to the operator interface for visualization and storage. Once generated, the image is packaged as the final payload result and transmitted to the DJI-side interface. This separation keeps the real-time monitoring path lightweight while preserving the quality of the final SAR image product.

2.5 Mechanical System Design

The mechanical enclosure system was designed to support integration between the radar frontend, onboard processing hardware, PCB assemblies, wiring interfaces, and the UAV mounting structure. The final enclosure consists of a detachable upper cover and lower enclosure body fabricated using 3D printing technology. The enclosure was designed to provide structural rigidity during UAV operation while maintaining accessibility for subsystem assembly, debugging, and maintenance.

During subsystem integration and assembly, several enclosure revisions were required to accommodate practical hardware constraints identified throughout testing. Initial enclosure dimensions were insufficient to support simultaneous placement of the NVIDIA Jetson Orin Nano development board, RF circuitry, PCB assemblies, and associated wiring interfaces within the payload structure. As a result, the enclosure geometry, internal layout, and mounting arrangement were iteratively redesigned throughout the integration process.

The enclosure width and internal clearance were increased to accommodate the Jetson Orin Nano development board and provide sufficient spacing between the onboard processor, RF frontend, and PCB assemblies. The enclosure length was also adjusted multiple times during development to balance wiring accessibility, subsystem placement, and compatibility with the UAV gimbal-supported payload structure. These modifications were necessary because the onboard processor, RF circuitry, and PCB assemblies needed to remain in close proximity while still maintaining sufficient clearance for cable routing and gimbal rotation during UAV operation.

Special consideration was given to wire routing between the Jetson platform, RF circuitry, and gimbal assembly. The limited cable length between subsystems required the routing openings and internal layout to be redesigned to reduce cable bending and simplify internal wiring paths. Openings were repositioned to allow cables from the Jetson platform to exit through the enclosure side wall and loop back toward the RF and PCB assemblies while avoiding interference with the payload structure and gimbal movement.

Figure 6 shows the dimensional engineering layout of the enclosure body structure. The layout defines the overall enclosure dimensions, mounting hole placement, and subsystem integration geometry used during fabrication. Figure 7 illustrates the primary 3D CAD renderings of the enclosure body and detachable cover used in the final payload assembly. Additional enclosure fabrication drawings and supplementary render views are provided in Appendix A.

Mechanical fastening and vibration stability during UAV operation were also considered

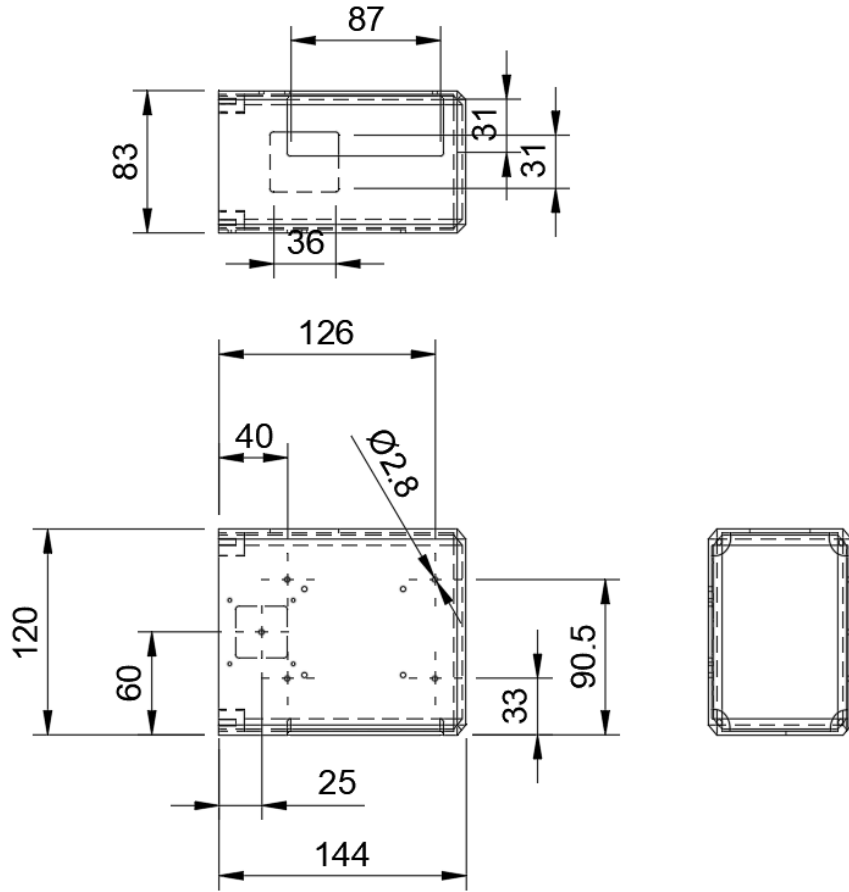

Figure 6: Dimensional layout of the enclosure body structure

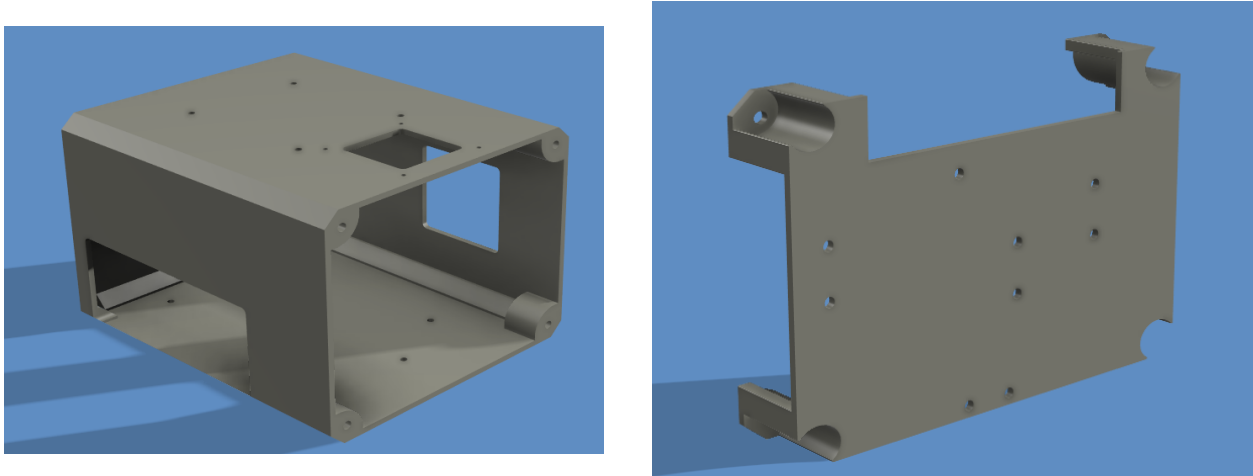

Figure 7: 3D CAD renderings of the enclosure body and detachable cover

throughout the enclosure design process. Dedicated mounting holes and internal support structures were incorporated to securely fasten the Jetson board, PCB assemblies, and RF components within the enclosure. Because the RF circuitry required vertically

stacked mounting and precise spacing between assembled components, layered screw mounts and custom support spacing were integrated into the enclosure structure to maintain alignment and prevent component displacement during flight operation.

The detachable upper cover was designed to support mounting of the RF circuitry while also allowing simplified subsystem assembly and maintenance access. The mounting hole locations were positioned using measured spacing from the assembled RF circuitry to ensure alignment between the RF components, PCB assemblies, and layered screw supports. These mounting points were used to mechanically stack and secure the RF circuit components within the enclosure during UAV operation.

The final enclosure geometry balances subsystem accessibility, wiring clearance, structural rigidity, vibration resistance, and compatibility with the UAV-mounted gimbal-supported payload assembly. All enclosure components were manufactured using 3D printing technology, enabling rapid prototyping, iterative dimensional modification, lightweight fabrication, and subsystem-specific customization suitable for UAV payload integration.

2.6 PCB Design

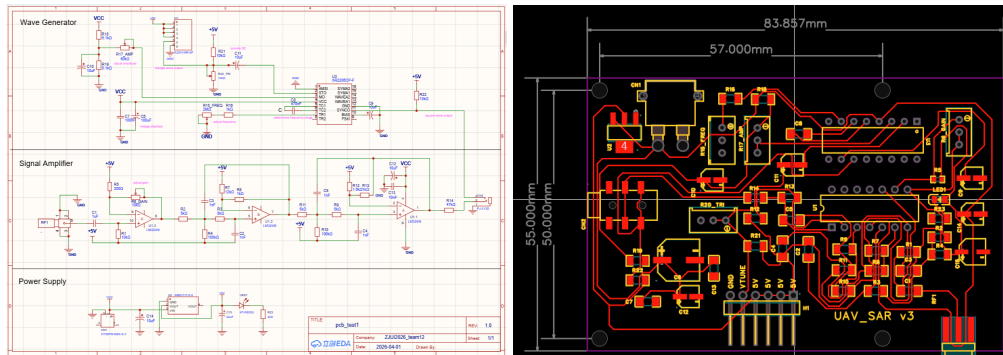

Figure 8: Our PCB

The PCB mainly needs to implement two functions. The first function is to provide a waveform for the RF circuit to generate linear frequency modulation waves. The second function is to filter and amplify the mixed signal received by the mixer. The final PCB is divided into three main functional sections: the wave generator, the signal amplifier, and the power supply. Detailed descriptions are provided below:

2.6.1 Wave Generator

The wave generator section is built around the XR2206 function generator IC. This circuit is designed to generate configurable low-frequency test waveforms, including a triangle-wave output for the voltage-controlled oscillator and a square-wave output for the ADC board. The oscillation frequency and amplitude are mainly determined by the external

timing capacitor and adjustable resistor network connected to the XR2206. In this project, we need a 0.8 V peak-to-peak voltage and a 50 Hz triangular wave.

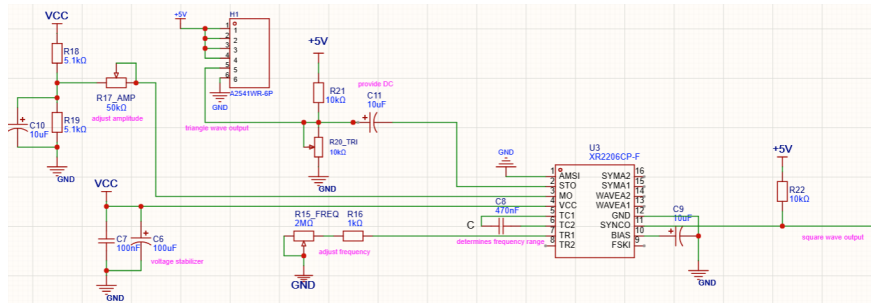

Figure 9: Wave generator

2.6.2 Signal Amplifier

The signal amplifier section uses a fourth-order low-pass filter to filter out high-frequency components from the mixer. We set the cutoff frequency to 20 kHz so that the maximum detection distance is

$$D_{max} = \frac{f_{max} \cdot c}{2K_r} = \frac{2 \times 10^3 \times 3 \times 10^8}{2 \times 6 \times 10^9} = 500m$$

The filtered signal is then passed to an amplifier, whose gain can be modified by adjusting the adjustable resistor. As long as the output level is less than the maximum output of the chip, the gain is expected to be about 30 dB maximum.

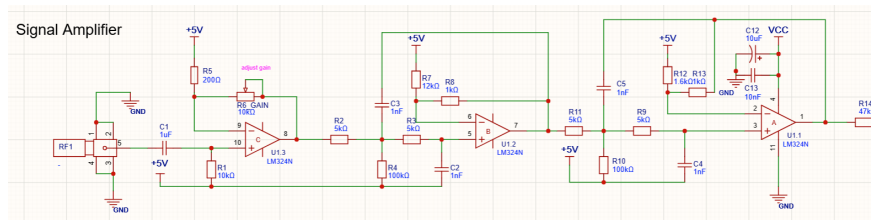

Figure 10: Signal amplifier

2.7 Power Supply

The power supply section uses an AMS1117-5.0 linear voltage regulator to generate a regulated +5 V rail from the external input supply. This regulated voltage is used to power the waveform generation and signal-conditioning circuits. Input and output capacitors are included to improve voltage stability and reduce power-supply noise. An LED indicator with a current-limiting resistor is also included to provide visual confirmation that the board is powered.

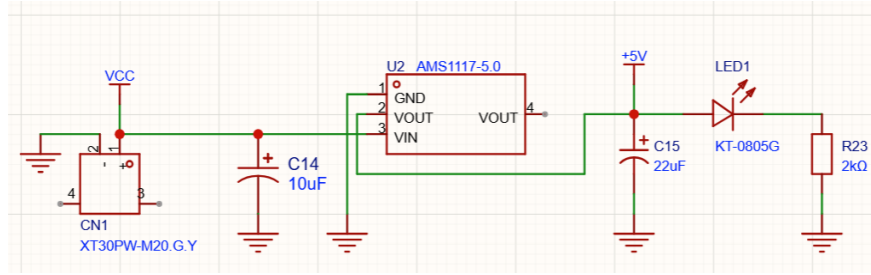

Figure 11: Power supply

2.7.1 Project Schedule

Table 1 summarizes the project schedule and division of responsibilities.

Table 1: Project schedule and team responsibilities

Week	Yinfei Ma	Chenxiao Wang	Giselle	Victoria
03/30/2026	Study DJI PSDK communication and telemetry interfaces; contribute to system integration planning	Investigate SAR imaging algorithms, RF subsystem requirements, and PCB design planning	Design the initial processing pipeline and subsystem interfaces	Develop the system block diagram and begin mechanical integration planning
04/13/2026	Implement telemetry retrieval, command handling, and radar data logging	Complete PCB schematic and layout design; evaluate RF subsystem constraints	Refine enclosure layout, subsystem placement, and processing pipeline	Develop enclosure CAD model and hardware mounting structure
04/27/2026	Improve communication reliability and synchronize payload operations	Prepare PCB assembly and evaluate RF subsystem integration	Fabricate enclosure prototype and evaluate wiring accessibility	Refine cable routing, fastening structure, and gimbal compatibility
05/04/2026	Integrate UAV communication software with the onboard payload pipeline	Assemble and test PCB waveform generation and signal amplification stages	Finalize enclosure dimensions and mechanical mounting structure	Integrate hardware into enclosure and debug subsystem wiring stability
05/11/2026	Perform system-level communication testing and telemetry validation	Verify PCB and RF subsystem functionality through integration testing	Support subsystem integration testing and enclosure refinement	Perform mechanical debugging, reliability evaluation, and integration support
05/18/2026	Final system testing, demonstration preparation, and presentation support	Final system testing, demonstration preparation, and presentation support	Final system testing, demonstration preparation, and presentation support	Final system testing, demonstration preparation, and presentation support

3 Testing and Verification

3.1 PCB Testing

For the PCB, we mainly tested two functions: waveform generation and echo signal processing.

For waveform generation testing, by adjusting the values of the variable resistors, we generated waveforms with the required frequency, amplitude, and shape. As observed on the oscilloscope, we successfully generated a triangular wave with an amplitude of $0.8 V_{pp}$ and a frequency of 50 Hz, as well as a square wave with a frequency of 50 Hz.

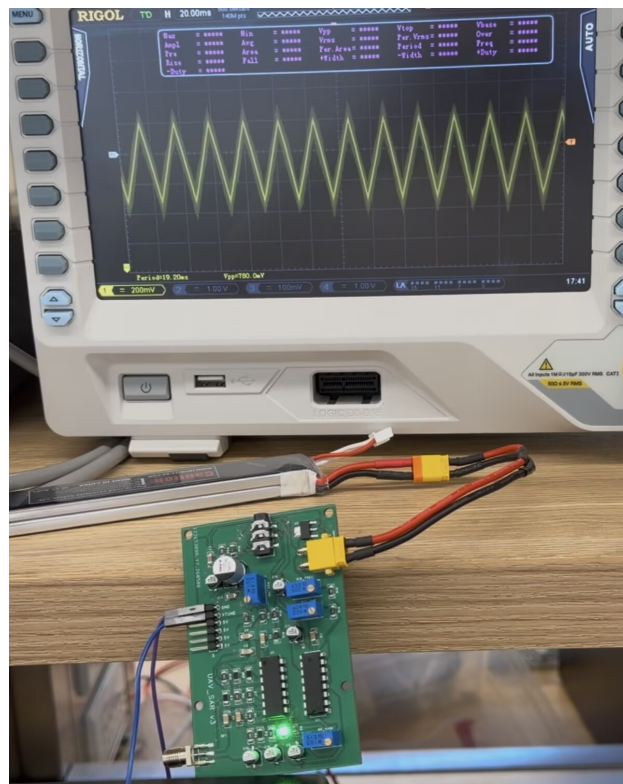

Figure 12: Wave generation testing

For the echo signal processing part, we used a function generator to input a cosine wave with an amplitude of $10 mV_{pp}$ and a frequency of 1000 kHz. We then measured the pre-processed output signal sent to the ADC board. The output waveform showed $500 mV_{pp}$, which is about a 50-fold increase in amplitude compared to the input waveform, confirming that the PCB design functions correctly. The SNR measured in the amplified signal is about 7.3 dB, which satisfies the requirements.



Figure 13: Wave amplifier testing

3.2 RF Testing

We used an oscilloscope to detect the echo of the antenna and a metal plate to cover the antenna. The results are shown below:



Figure 14: Antenna test

The waveform on the left side of the figure shows the waveform before the cover, and the waveform on the right side shows the waveform after the cover. It can be seen that the waveform has undergone significant changes. We can consider the antenna to be working effectively.

3.3 Communication and Telemetry Testing

The communication and telemetry subsystem was tested by establishing communication between the onboard processing unit, the DJI Extension Board, and the UAV platform.

The onboard computer was connected to the DJI communication interface through UART and network connections. Preliminary tests were performed to verify the initialization of communication and the retrieval functionality of telemetry. During testing, the onboard processing unit successfully received UAV position and telemetry information from the DJI platform.

Simple communication programs were also executed to verify stable data exchange between the payload computer and UAV system. The results confirmed that communication between the onboard processing subsystem and UAV platform was successfully established.

3.4 SAR Processing Verification

The onboard SAR processing pipeline was verified using simulated radar datasets and preliminary processing tests on the NVIDIA Jetson Orin Nano platform [5].

Signal preprocessing operations including filtering and noise reduction were first applied to the radar data before range-domain processing. Fourier transform operations were then performed to convert the radar signal into the frequency domain for SAR image reconstruction.

Verification was performed by comparing the GPU reconstruction output against a conventional backprojection reference. The reference BP implementation provides a high-quality baseline because it directly evaluates the contribution of each pulse to each image pixel. The CUDA implementation was first checked against this baseline on smaller image grids to confirm numerical consistency and correct phase behavior. Timing measurements were then collected on the Jetson Orin Nano to evaluate whether the reconstruction could meet onboard processing requirements.

The verification results show that GPU acceleration provides a substantial reduction in processing time, and that the factorized structure further reduces the cost of coherent summation. The FFBP implementation therefore provides the intended tradeoff for the system: high-quality SAR image formation with significantly lower computational load than full backprojection, making it the chosen algorithm for the final onboard UAV SAR imaging pipeline.

Figure 15 shows the timing breakdown of the GPU-accelerated FFBP imaging pipeline. The complete processing pipeline required approximately 2.8 s to process a pre-recorded radar dataset, demonstrating that the system can satisfy the real-time processing requirement.

```
Timing summary, slowest first:
 1.280s  46.10%  ffbp final coherent sum gpu
 0.505s  18.17%  save figure
 0.404s  14.57%  range compression fft gpu
 0.144s   5.19%  factorize subapertures gpu
 0.128s   4.61%  pulse detection and hilbert transform
 0.097s   3.48%  plot pcolormesh
 0.072s   2.60%  transfer input to gpu
 0.051s   1.83%  read wav
 0.031s   1.11%  mean subtraction and range window
 0.020s   0.71%  plot labels and colorbar
 0.017s   0.62%  cuda device check
 0.014s   0.50%  log scale gpu to cpu
 0.008s   0.29%  plot create figure
 0.003s   0.10%  build straight path and image grid gpu
 0.000s   0.00%  clip and flip signal
 0.000s   0.00%  setup output path
 0.000s   0.00%  compile ffbp raw kernels
 2.776s  100.00%  total
```

Figure 15: FFBP processing timing results

3.5 Mechanical Verification

The mechanical subsystem was verified by CAD inspection, enclosure assembly evaluation, and 3D printing preparation.

Several enclosure revisions were performed to improve board clearance, cable routing accessibility, and compatibility with the UAV mounting structure. The enclosure dimensions were adjusted to provide additional spacing for the onboard circuitry and wiring.

The enclosure length was increased to better accommodate onboard circuitry and subsystem wiring. In addition, one side opening was widened to simplify cable access and improve connector accessibility during assembly and debugging.

Particular attention was paid to cable routing near the UAV gimbal structure. The internal wiring paths and the placement of components were adjusted to reduce possible interference with the movement of the gimbal during operation.

The final enclosure revision was prepared for 3D printing and evaluated for printability, support placement, and structural stability.

3.6 Integration Results

Subsystem integration testing was performed to evaluate communication, power delivery, and interaction between major hardware modules.

The onboard processing unit, communication interface, radar subsystem, and mechanical enclosure were assembled within the integrated payload structure. Preliminary testing

verified successful communication between the onboard computer and UAV platform while supporting radar operation and local processing tasks.

Ground-based testing was also performed to evaluate subsystem synchronization, cable stability, and communication reliability.

The integrated system demonstrated successful coordination between sensing, communication, processing, and mechanical subsystems, representing substantial progress toward a UAV-mounted SAR platform.

3.7 System Limitations and Tradeoffs

Although the project demonstrated subsystem integration and onboard processing capability, several limitations remain.

SAR image quality and radar signal stability may be affected by antenna positioning, environmental reflections, vibration, and UAV motion. Additional calibration and flight testing are required to further evaluate system performance.

While the NVIDIA Jetson Orin Nano provides strong embedded processing capability, real-time SAR image generation remains computationally intensive for larger radar datasets and higher-resolution images.

Mechanical integration also introduced tradeoffs between enclosure size, payload weight, cooling requirements, and cable access. Enlarging the enclosure improved board clearance and wiring ease, but increased payload dimensions and structural complexity.

3.8 Summary

Testing and verification demonstrated successful subsystem functionality and substantial progress toward implementing a UAV-mounted FMCW SAR platform with onboard processing capability.

PCB testing verified waveform generation and signal amplification functionality, while RF testing confirmed preliminary radar transmission and reception capability. Communication testing verified telemetry exchange between the onboard computer and UAV platform, and SAR processing verification confirmed successful execution of the onboard processing pipeline. Mechanical verification and subsystem integration testing further demonstrated successful enclosure redesign and compatibility between onboard hardware components and the UAV payload structure. Detailed verification summaries are provided in Appendix B.

4 Cost

4.1 Parts

Table 2 summarizes the estimated hardware and manufacturing cost of the completed system, including the embedded computing platform, PCB fabrication, electronic components, and mechanical structure materials.

Table 2: Estimated hardware and fabrication cost of the completed UAV-mounted FMCW SAR system

Category	Item Description	Estimated Cost (¥)
Edge Computing Platform	NVIDIA Jetson Orin Nano Developer Kit (8 GB)	2500
	NVMe M.2 SSD	800
PCB and Electronics	PCB fabrication	120
	PCB components	200
	ADC/DAC interface components	500
	Miscellaneous electronic components	100
Mechanical Structure	3D printing materials	200
	Mounting hardware and vibration isolators	50
Total		4470

4.2 Labor

Assuming that each of us has a labor rate of ¥50/hour, the total construction period is estimated to be 120 hours. The total labor cost is calculated as:

$$\text{¥}50/\text{hr} \times 4 \times 120\text{hrs} = \text{¥}24000 \simeq \$3430 \quad (1)$$

5 Conclusion

5.1 Accomplishments and Uncertainties

This project developed a UAV-mounted FMCW SAR platform integrating radar sensing, onboard processing, communication control, and a custom enclosure into a unified embedded system.

The RF and PCB subsystems demonstrated waveform generation, signal amplification, and radar signal acquisition functionality. Communication between the onboard computer and DJI platform was established through the DJI Payload SDK interface.

An onboard SAR processing pipeline was implemented on the NVIDIA Jetson Orin Nano platform, including signal preprocessing, range processing, and preliminary SAR image reconstruction. The project demonstrated the feasibility of onboard SAR sensing and processing on a UAV platform.

Although significant progress was achieved, several limitations remain. SAR image quality may still be affected by motion disturbances, antenna alignment, environmental reflections, and UAV vibration. Additional calibration and flight-based testing are required to further evaluate system performance.

Real-time processing also remains computationally intensive for larger radar datasets and higher-resolution image generation. Mechanical integration challenges related to payload wiring and operational stability also require further refinement.

5.2 Ethical Considerations

This project involves UAV operation, FMCW radar sensing, onboard computation, wireless communication, and local data storage. Therefore, the main ethical concerns are public safety, privacy, RF compliance, cybersecurity, and accurate reporting of system limitations. Following the IEEE Code of Ethics, the project was intended for engineering research and environmental sensing rather than personal surveillance, and the team aimed to prioritize safety, responsible data use, and honest communication of technical results.

The primary safety risk comes from mounting custom radar and computing hardware on a UAV. Loose wiring, unstable mounting, gimbal interference, or payload imbalance could create hazards during operation. To reduce these risks, the system was first tested on the ground, and the enclosure was redesigned to improve component fastening, cable routing, board clearance, and compatibility with the UAV payload structure. Future flight tests should be performed only in approved open areas with a pre-flight checklist covering payload attachment, cable clearance, battery condition, communication status, and emergency procedures.

Because the system transmits FMCW radar signals, RF safety and interference must also be considered. Radar operation should remain within permitted frequency bands and power limits, and testing should be limited to controlled laboratory or approved outdoor

environments. If unstable RF output or unexpected interference is observed, transmission should be stopped until the issue is identified.

Privacy is another concern because radar sensing can collect information about objects and environments without visible-light imaging. Data collection should therefore be limited to approved test scenes and should avoid private areas or uninformed bystanders. Raw radar data, telemetry logs, and reconstructed SAR images should be stored only for project validation, shared only with authorized team members and course staff, and deleted when no longer needed.

The communication interface also introduces cybersecurity risks. Payload commands and data transfer should be restricted to trusted DJI PSDK and onboard control interfaces, and the system should not be connected to untrusted networks during testing. Finally, the team should clearly report unresolved limitations, including incomplete flight testing, motion sensitivity, vibration effects, antenna alignment issues, and the difference between onboard processing tests and full end-to-end real-time operation.

5.3 Future Work

Future work will focus on completing full flight-based SAR testing and improving overall system performance under real operating conditions. Additional testing may further evaluate image quality, motion sensitivity, telemetry reliability, and system stability during UAV flight.

Further optimization of the SAR processing pipeline may improve image quality, processing speed, and motion compensation capability. Additional GPU acceleration and algorithm refinement may also reduce onboard processing latency and improve real-time performance for larger radar datasets.

Mechanical improvements may include lighter enclosure materials, improved thermal management, enhanced vibration isolation, and more compact subsystem integration. Future enclosure revisions may also improve accessibility for wiring, maintenance, and payload assembly.

Additional future development may include improved operator visualization interfaces, automated mission control integration, and more advanced SAR imaging techniques. Future versions of the system may also investigate higher-resolution radar sensing, improved calibration methods, and more robust real-time onboard image reconstruction.

References

- [1] D. G. Gaviria, B. Geiger, C. Muth, and L. Schmalen, *On the sensing performance of fmcw-based integrated sensing and communications with arbitrary constellations*, arXiv:2503.17215. Accessed: 2026-04-06, Mar. 2025. [Online]. Available: <https://arxiv.org/pdf/2503.17215>.
- [2] J. Svedin, A. Bernland, A. Gustafsson, E. Claar, and J. Luong, "Small UAV-based SAR system using low-cost radar, position, and attitude sensors with onboard imaging capability," *International Journal of Microwave and Wireless Technologies*, vol. 13, no. 6, pp. 602–613, Mar. 2021. DOI: 10.1017/s1759078721000416.
- [3] H. Cruz, M. Vestias, J. Monteiro, H. Neto, and R. P. Duarte, "A Review of Synthetic Aperture Radar Image Formation Algorithms and Implementations: A Computational Perspective," *Remote Sensing*, vol. 14, no. 5, p. 1258, Mar. 2022, Accessed: 2026-05-15. DOI: 10.3390/rs14051258. [Online]. Available: <https://www.mdpi.com/2072-4292/14/5/1258>.
- [4] M. S. Hossain and G. Muhammad, "UAV-Based Remote Sensing System: Challenges and Opportunities," in *IEEE International Conference on Artificial Intelligence and Industrial Design*, IEEE, 2021, pp. 366–369. DOI: 10.1109/AIID51893.2021.9472713. [Online]. Available: <https://ieeexplore.ieee.org/document/9472713/>.
- [5] NVIDIA Corporation, *Jetson Orin Nano Series Modules Data Sheet*, Version 1.7, DS-11105-001. Accessed: 2026-04-08, NVIDIA Corporation, Mar. 2026. [Online]. Available: <https://developer.nvidia.com/embedded/downloads>.
- [6] DJI, *Matrice 300 RTK User Manual*, Version 4.0. Accessed: 2026-04-07, DJI, May 2023. [Online]. Available: https://dl.djicdn.com/downloads/matrice-300/20230518UM/M300_RTK_User_Manual_EN_v4.0.pdf.
- [7] NASA Earthdata, *Synthetic Aperture Radar (SAR)*, Accessed: 2026-04-07, NASA, May 2021. [Online]. Available: <https://www.earthdata.nasa.gov/learn/earth-observation-data-basics/sar>.

Appendix A Mechanical Design Appendix

This appendix contains supplementary mechanical fabrication drawings and additional CAD renderings of the UAV-mounted FMCW SAR enclosure structure referenced in Section 2.5.

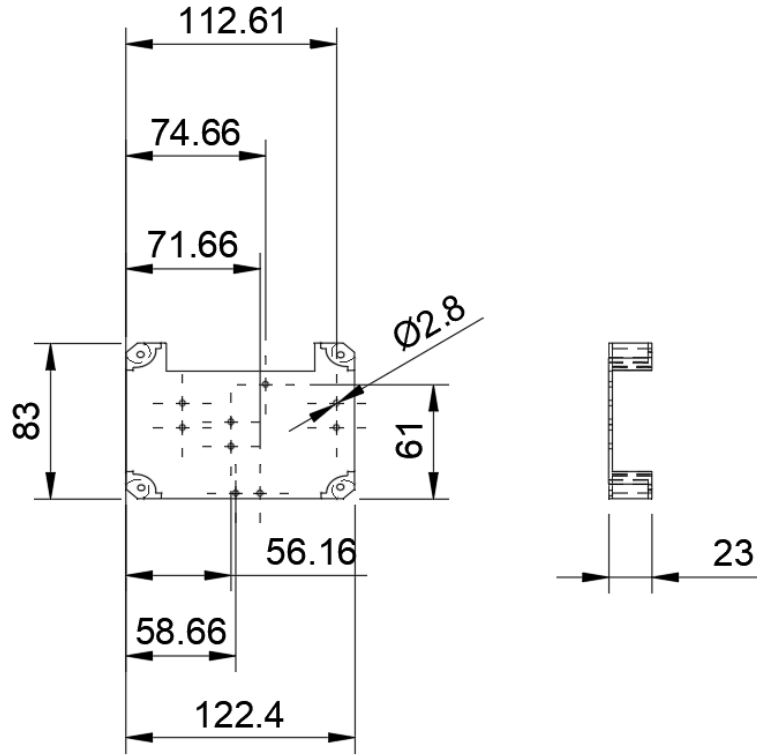

Figure 16: Dimensional layout of the detachable enclosure cover

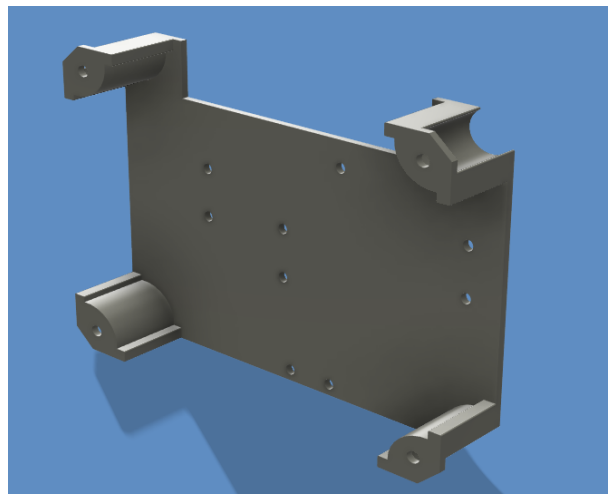
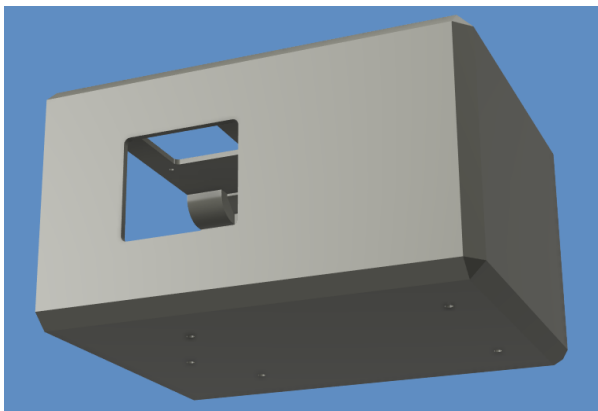

Figure 17: Supplementary CAD renderings of the enclosure structure

Appendix B Requirement and Verification Tables

This appendix summarizes subsystem requirements, verification methods, and current implementation status.

Table 3: RF sensing verification summary

Requirement	Verification Method	Status
FMCW radar signals are generated successfully	Reference waveform measurements and signal inspection	Verified
Radar signals are transmitted toward the target region	Ground-based transmission testing	Partially Verified
Reflected signals are received by the antenna	Controlled target reflection testing	Partially Verified
Analog radar signals are transferred to the acquisition subsystem	Signal continuity and interface testing	Verified

Table 4: UAV and flight control verification summary

Requirement	Verification Method	Status
The UAV follows predefined flight paths	Mission planning and telemetry validation	Partially Verified
The UAV maintains stable orientation during operation	Ground-based orientation testing	In Progress
The processing unit communicates with the UAV platform	Position data retrieval through DJI interface	Verified
The UAV supplies sufficient power to onboard systems	Power budgeting and voltage inspection	Verified

Table 5: Signal acquisition verification summary

Requirement	Verification Method	Status
Radar signals are amplified and filtered	Oscilloscope comparison before and after conditioning	Verified
Noise is reduced prior to ADC sampling	Signal-to-noise ratio comparison	Partially Verified
Analog radar signals are digitized correctly	ADC output validation	In Progress
Digitized data is transferred successfully	Data transmission testing to processing unit	In Progress
Stable power is maintained during acquisition	Voltage stability measurements	Verified

Table 6: Onboard processing verification summary

Requirement	Verification Method	Status
Radar data is preprocessed for noise reduction	Simulation and preprocessing comparison	Verified
FFT-based range processing is implemented	Frequency-domain output inspection	Verified
SAR image reconstruction is performed using RMA	Simulation-based image reconstruction testing	Partially Verified
Motion data improves imaging accuracy	Comparative simulation testing	In Progress
Real-time onboard processing is supported	Embedded processing latency measurements	In Progress

Table 7: Communication and control verification summary

Requirement	Verification Method	Status
SAR images are transmitted to the operator interface	Display interface and communication testing	In Progress
Control commands are received and processed	Operator command testing	Partially Verified
Reliable communication is maintained	Telemetry and data consistency testing	Partially Verified
DJI SDK integration is supported	SDK interface validation	Verified