

# INTELLIGENT FIRE PROTECTION ECOSYSTEM

By

Xiaohua Ding

(xiaohua5@illinois.edu)

Jiawei Zhu

(jiawez6@illinois.edu)

Honglei Zhu

(honglei3@illinois.edu)

Final Report for ECE 445, Senior Design, Spring 2024

TA: Jiahao Chen; Jianxin Zhang

05 May 2024

Project No. 16

## **Abstract**

In today's rapidly evolving urban environments, securing buildings against fire hazards continues to be a major concern. Traditional fire protection systems, while effective to some extent, are often unable to meet the dynamic challenges posed by modern infrastructure and various fire risks. In this paper, we design an intelligent fire protection system, which is based on smoke sensing detectors, combustible gas detectors, audible and visual alarms, and manual call points, as well as a fire data visualization platform. This fire protection system will better cope with today's residential environment and improve the accuracy of fire detection.

# Contents

- 1. Introduction ..... 1
  - 1.1 Introduction ..... 1
  - 1.2 Background ..... 1
  - 1.3 Subsystem ..... 2
    - 1.3.1 Wireless Smoke Sensor ..... 2
    - 1.3.2 Wireless combustible gas detector ..... 2
    - 1.3.3 Wireless audible and visual alarms and wireless manual alarm buttons ..... 2
    - 1.3.4 Fire visualization platform: ..... 2
- 2 Design ..... 3
  - 2.1 Combustible Gas Alarm System ..... 3
    - 2.1.1 Description: ..... 3
    - 2.1.2 Justification & Simulation ..... 5
    - 2.1.3 Design Alternatives ..... 5
  - 2.2 Smoke Alarm System ..... 5
    - 2.2.1 Description: ..... 5
    - 2.2.2 Justification & Simulation ..... 5
    - 2.2.3 Design Alternatives ..... 6
  - 2.3 Wireless Manual Call Points System ..... 7
    - 2.3.1 Description: ..... 7
    - 2.3.2 Justification & Simulation ..... 9
    - 2.3.3 Design Alternatives ..... 9
  - 2.4 Demo Box ..... 9
    - 2.4.1 Description: ..... 9
    - 2.4.2 Design Alternatives ..... 10
- 3. Design Verification ..... 10
  - 3.1 Verification of the Smoke Alarms ..... 11
    - 3.1.1 Experimental Design ..... 11
    - 3.1.2 Experimental Procedures ..... 11
    - 3.1.3 Experimental Result ..... 12

3.2 Verification of the Combustible Gas Alarm .....	13
3.1.1 Experimental Design .....	13
3.1.2 Experimental Procedures.....	13
3.1.3 Experimental Results.....	13
3.2 Verification of the Manual Call Points .....	14
3.2.1 Experimental Design .....	14
3.2.2 Experimental Procedures.....	14
3.2.3 Experimental Results.....	15
3.3 Verification of the Functionality of a Battery Power Detection Module.....	16
3.3.1 Experimental Design .....	16
3.3.2 Experimental Procedures.....	16
3.3.3 Experimental Results.....	17
4. Costs.....	18
4.1 Parts .....	18
4.2 Labor .....	18
5. Schedule.....	19
6. Conclusion.....	20
6.1 Accomplishments.....	20
6.2 Uncertainties.....	20
6.2.1 Smoke sensors & combustible gas detectors .....	20
6.2.2 Audible and visual alarms and manual call points.....	21
6.3 Ethical considerations .....	21
6.4 Future work.....	22
References .....	23
Appendix A Requirement and Verification Table.....	24
Appendix B PCB Layout .....	26

# 1. Introduction

## 1.1 Introduction

There are a large number of old neighborhoods, where the electrical wiring and plumbing systems may be outdated and unable to meet the needs of modern fire protection systems due to the age of the buildings. In addition, most of the residents in old neighborhoods are elderly, which have mobility problems due to their age and are more prone to fire hazards in their daily lives. Therefore, fire protection retrofits are needed to ensure fire safety in these older neighborhoods.

Difficulties faced in fire protection retrofitting mainly include structural constraints of the building, aging infrastructure, and control of retrofitting costs. The need to rewire and install new equipment is technically difficult and can also cause disruption to residents' daily lives. In addition, residents' varying levels of awareness and importance of fire safety, coupled with possible barriers to adapting to and learning from the new system, add additional challenges to the promotion and implementation of fire safety retrofitting. At the economic level, budgeting for retrofitting costs is also a key factor, and there is a need to maximize the safety effect with limited resources. Moreover, traditional fire alarm equipment can only transmit alarm signals through signal wires, and fire alarm information can only be transmitted to the fire mainframe in the fire control room, which creates an information barrier. This requires that our intelligent fire protection system should not only meet the national standards for fire protection products but also be able to facilitate the installation, reduce the cost of fire protection construction and construction time, and also need to be able to multi-platform data transfer.

In order to solve the problem of high construction costs and information barriers in the renovation of old neighborhoods, we propose wireless smoke sensors and wireless combustible gas detectors, as well as wireless audible and visual alarms and wireless manual alarm buttons, which, together with our fire visualization platform, make up our intelligent fire ecosystem.

## 1.2 Background

The background of the problem is the inability of traditional fire protection systems to effectively respond to the ever-changing challenges posed by the modern built environment, with limited scope and means of data transmission. According to Illinois Fire Departments, there were over 1.4 million incidents, 92 civilian lives were lost and over \$476 million in property damage resulted from fires, according to the Office of the Illinois State Fire Marshal. and over \$476 million in property damage resulted from fires in 2022 [1]. As urbanization and technological advances continue to reshape our cities, the need for smarter, more responsive fire safety solutions is increasingly evident. According to the United States Fire Department, there is a fire in a residential area every 85 seconds and these fires account for almost 80 percent of all fire-related deaths [2, 3]. Traditional systems, which rely on simple detection methods and manual intervention, are mainly classified into photoelectric smoke detectors and ionization smoke detectors [4]. However, because conventional smoke alarms use a point light source (as shown in Figure 1), when detecting a single type of gas or smoke, the alarm threshold depends only on the shape of the detection chamber and the position and intensity of the light-emitting element (LED), which makes it difficult to adjust, does not provide real-time feedback on the

concentration of toxic or combustible gases, and is susceptible to false alarms due to the presence of a single sensor. For example, smoke generated at low ambient temperatures is not recognized as a fire, whereas a conventional alarm would. It is therefore essential to integrate multiple sensors and provide real-time feedback in an alarm.

## **1.3 Subsystem**

### **1.3.1 Wireless Smoke Sensor**

It can monitor the smoke concentration and temperature value in the air in real time and send out an alarm as soon as an abnormality is detected. Not only on-site alarm, but also can transmit the alarm information to the visualization platform remotely.

### **1.3.2 Wireless combustible gas detector**

It can monitor the concentration of combustible gas and temperature value in the air in real time and issue an alarm immediately once it detects the abnormality. It not only sends out alarms at the scene, but also can transmit the alarm information to the visualization platform remotely.

### **1.3.3 Wireless audible and visual alarms and wireless manual alarm buttons**

Manual alarm buttons allow personnel to actively trigger the alarm when witnessing an emergency, and audible and visual alarms emit audible and visual alarms immediately upon receiving the trigger signal from the manual alarm button.

### **1.3.4 Fire visualization platform:**

A platform that integrates all fire equipment information, displays real-time smoke concentration, real-time combustible gas concentration, real-time temperature data, and can be muted and de-alerted for false triggered alarms.

In response to the problem of laying lines and drilling pipes encountered in the renovation of old neighborhoods, wireless smoke sensors and wireless combustible gas detectors use wireless communication technology, which can avoid large-scale line construction, significantly reducing the construction difficulty and cost, not only to reduce the fire protection construction and renovation period, but also to reduce the construction of the interference with the tenants. Wireless audible and visual alarms and wireless manual alarm buttons enable rapid deployment and flexible installation using IoT wireless communication modules and self-contained battery power that can be mounted directly on existing structures without destroying walls or floors. In order to break the information barrier that alarm information can only be viewed in the fire control room, we have designed the Smart Fire Ecosystem to realize real-time sharing of alarm information through the esp8266 IoT module. This means that in the event of a fire, not only can the fire control room receive the alarm, but also the relevant information can be sent directly to property managers, residents and other relevant emergency response departments through the computer-based fire data platform and mobile applications. This real-time information sharing mechanism greatly improves the speed and efficiency of emergency response and ensures that effective countermeasures can be taken in the early stages of a fire.

## 2 Design

The whole project is mainly divided into 4 subsystems: Combustible Gas Alarm System, Smoke Alarm System, Wireless Manual Call Points System, and demo box. Figure 2 is project's block diagram which shows the fundamental connection between different subsystems.

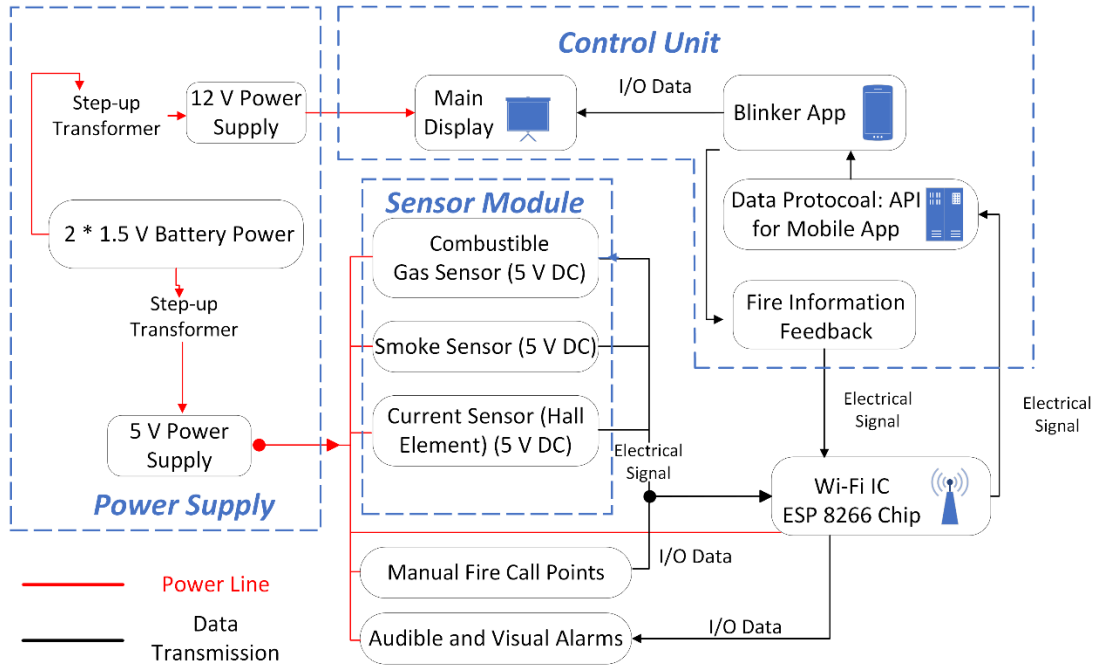

Figure 1 Block diagram

### 2.1 Combustible Gas Alarm System

#### 2.1.1 Description:

As shown in Figure 2 and circuit diagram, Figure 3, the Combustible Gas Alarm Platform is an advanced safety system designed to detect and alert for dangerous concentrations of combustible gases and excessive temperatures in the environment. By having a combination of the ESP8266 Wi-Fi module, MQ-5 gas sensor, and DHT-11 temperature sensor, this platform ensures real-time monitoring with high sensitivity and accuracy.

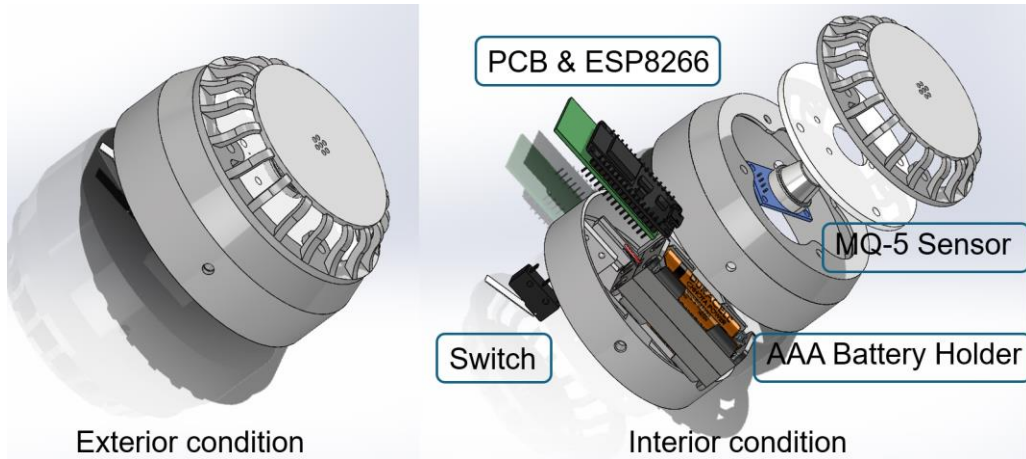

Figure 2 Exterior and interior structure of the combustible gas alarms

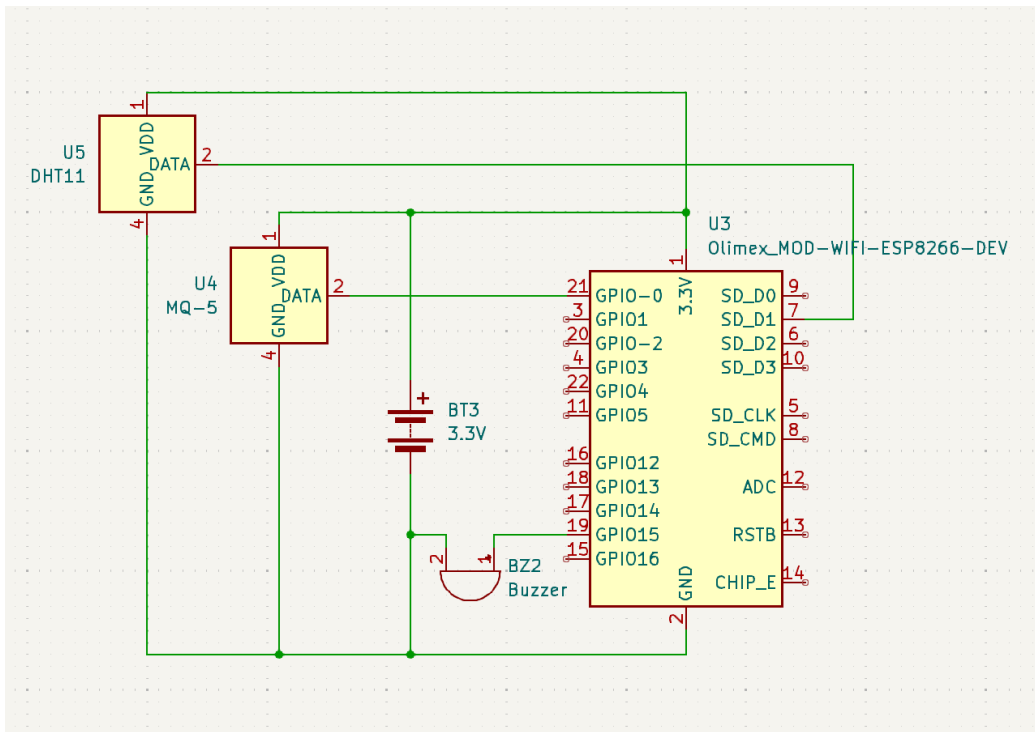

Figure 3 Basic circuit diagram of the combustible gas alarms

The ESP8266 microcontroller processes data from the MQ-5 sensor, which is specifically engineered to detect a wide range of combustible gases. And the DHT-11 complements this by monitoring the ambient temperature, adding an additional layer of safety by detecting potential fire conditions. When both the gas concentration and temperature exceed predefined thresholds—500 units for gas density and 200 units for temperature—the system activates a loud buzzer to warn of potential danger, ensuring prompt awareness and reaction.

The real time sensor value can be monitored on [bemfa.cloud](http://bemfa.cloud) on our PCs to give a convenient approach to check the situation around our houses or factories during in a timely-manner.



### **2.1.2 Justification & Simulation**

ESP8266 Wi-Fi Module: This microcontroller was selected for its built-in Wi-Fi capabilities, which are essential for implementing the necessary TCP/IP networking functions without the need for additional modules. The ESP8266 is also favored for its affordability and widespread community support, making it an ideal choice for rapid development and troubleshooting.

MQ-5 Gas Sensor: The choice of the MQ-5 sensor is justified by its sensitivity to a range of combustible gases, including methane and propane, which are common in both residential and industrial settings. This sensor provides reliable readings and is capable of operating under a variety of environmental conditions, which is critical for the diverse applications of the alarm system.

DHT-11 Temperature Sensor: The DHT-11 was selected for its ability to provide ambient temperature readings. Temperature is a crucial parameter in detecting potential fire hazards when combined with gas concentration levels. The DHT-11 is not only cost-effective but also sufficiently accurate for the temperature ranges expected in the target environments of the platform.

### **2.1.3 Design Alternatives**

Sensor Selection: The MQ-5 was chosen for its sensitivity to a broad range of combustible gases. Alternative sensors like the MQ-2 were considered but were not selected due to their broader sensitivity range, which was not required for this specific application.

Microcontroller Choice: The ESP8266 was preferred over options like Arduino due to its integrated Wi-Fi capability, essential for remote and wireless data transmission and control.

## **2.2 Smoke Alarm System**

### **2.2.1 Description:**

As shown in Figure 4 and circuit diagram, Figure 5, the Smoke Alarm detects and alarms the concentration of smoke and excessive temperatures in the environment. The platform combines the ESP8266 Wi-Fi module, the MQ-2 smoke sensor and the DHT-11 temperature sensor to ensure highly sensitive and accurate real-time monitoring.

The ESP8266 microcontroller processes data from the MQ-2 sensor, which is specifically designed to detect smoke data. The DHT-11 complements this by monitoring the ambient temperature, adding a layer of safety by detecting potential fire conditions. When smoke concentrations and temperatures exceed pre-set thresholds (400 units for smoke concentration and 50 degrees Celsius), the system activates a loud buzzer to warn of potential danger, ensuring that people are quickly aware and can react.

Real-time sensor values can be monitored via bemfa.cloud on a PC, making it easy to see what's going on around a house or common area in a timely manner.

### **2.2.2 Justification & Simulation**

The ESP8266 module has been selected for its integrated Wi-Fi functionality, which is essential for facilitating vital TCP/IP network operations. This feature negates the necessity for supplementary

modules, streamlining the system's networking capabilities. Moreover, the ESP8266 is recognized for its cost-effectiveness and robust community backing, which are significant advantages for swift prototyping and problem-solving processes.

For detecting and measuring smoke levels, the MQ-2 sensor has been employed due to its precision in delivering feedback on smoke concentration. It is engineered to offer dependable readings across diverse environmental scenarios, making it a crucial component for a broad spectrum of alarm system applications.

The DHT-11 sensor has been included for its effectiveness in measuring the surrounding temperature. When integrated with gas concentration data, temperature measurements are pivotal in the early detection of fire risks. The DHT-11 stands out for its economic efficiency and adequate precision for the temperature spectrum anticipated within the platform's operational environment, positioning it as a versatile and budget-friendly sensor suitable for a wide array of applications.

### 2.2.3 Design Alternatives

**Sensor Selection:** The MQ-2 was selected because of its sensitivity to smoke concentrations and its concentration feedback of real-time smoke data. A light point type smoke sensor was also considered but was not chosen due to its limited sensitivity and lack of feedback on specific smoke concentrations.

**Microcontroller Selection:** The ESP8266 was favored over options such as the Arduino because of its integrated Wi-Fi capability, which is critical for remote wireless data transfer and control.

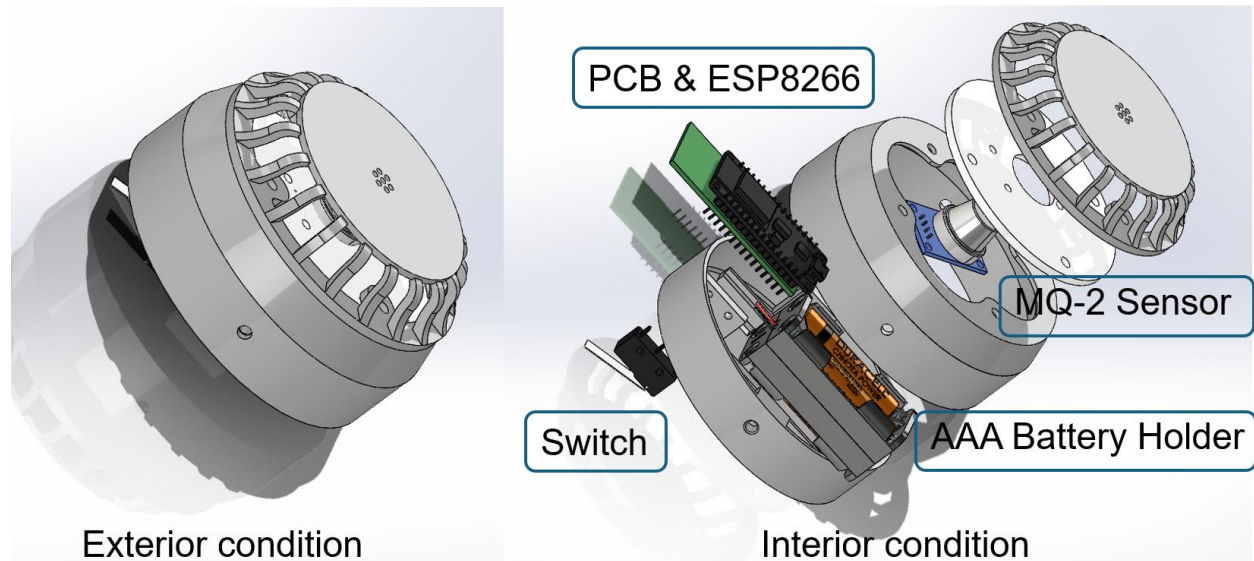

Figure 4 Exterior and interior structure of the smoke alarms

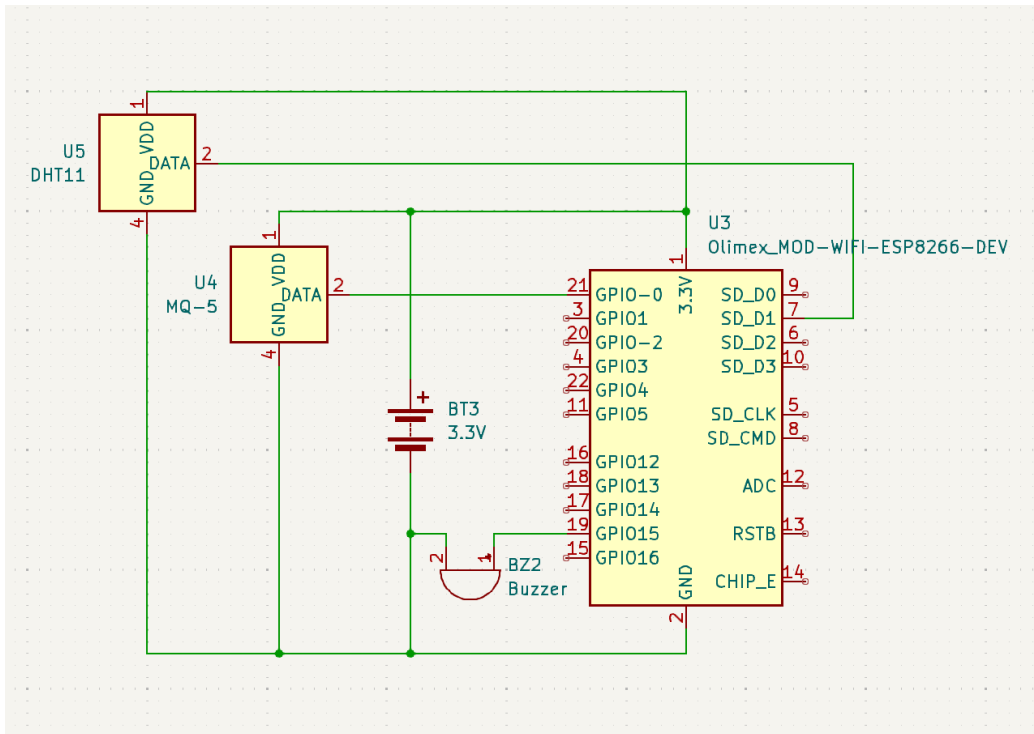

Figure 5 Basic circuit diagram of the smoke alarms

## 2.3 Wireless Manual Call Points System

### 2.3.1 Description:

As shown in Figure 6 and circuit diagram, Figure 7, the wireless manual call points system leverages two ESP8266 modules to establish a communication link that enables remote triggering of an alarm. This system is designed for environments where immediate notification of certain events, such as the detection of hazardous conditions or unauthorized entry, is crucial. The first ESP8266 (Sender or Station Mode) acts as the remote control, while the second ESP8266 (Receiver or Access Point Mode) activates the alert mechanisms.

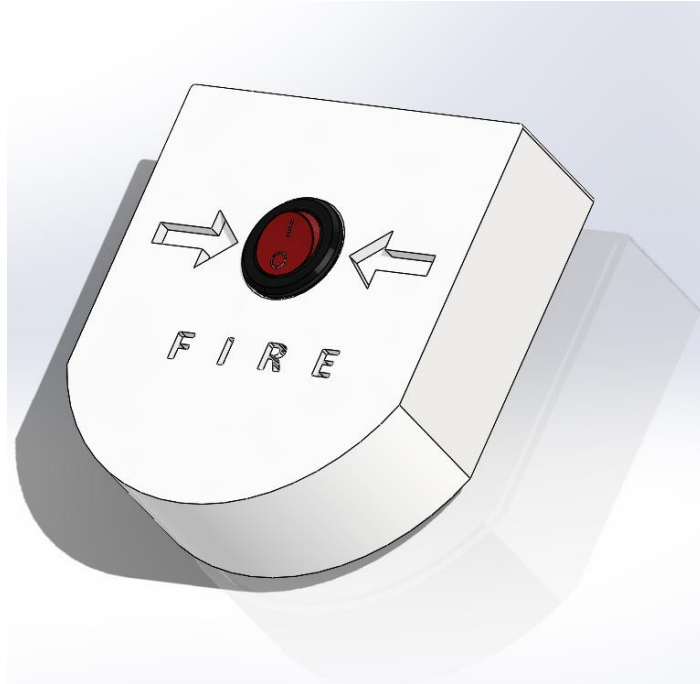

Figure 6 Exterior structure of the manual call points

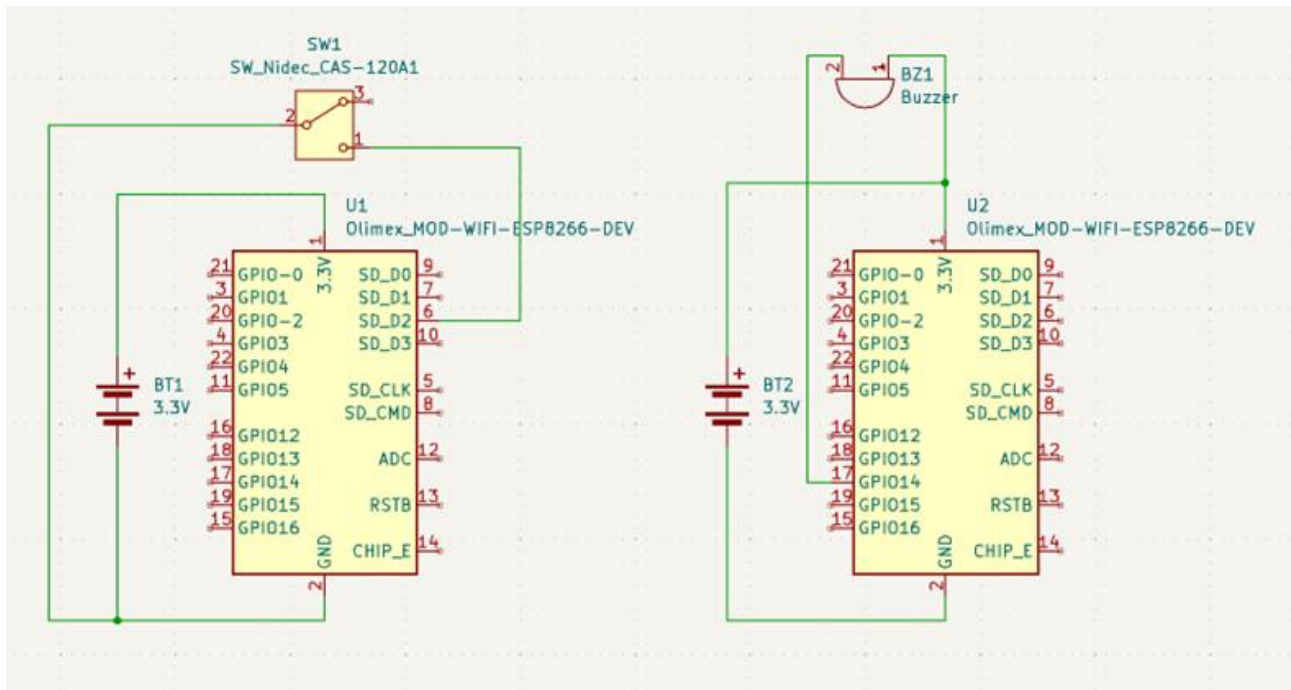

Figure 7 Basic circuit diagram of the manual call points and audible and visual alarms

The ESP8266 in station mode scans for and connects to the Wi-Fi network hosted by the second ESP8266 operating in Access Point mode. Equipped with physical buttons, the station module sends specific commands (e.g., "activate alarm") over the network when a button is pressed. The second

ESP8266 creates a Wi-Fi network and listens for station module. When receiving a command, it activates connected output devices — a buzzer for sound and an LED for visual indication.

When a button on the station module is pressed, it triggers a function to send a UDP packet with a command to the receiver. At the same time, the receiver module processes incoming commands and activates the alarm mechanisms accordingly.

### **2.3.2 Justification & Simulation**

To verify the effectiveness of the wireless manual call points system, simulations and tests are conducted to ensure robust communication over distances of 10-15 meters, which is a typical range for indoor environments or small industrial settings. These tests involve setting up the ESP8266 modules at various distances within this range to simulate real-world usage scenarios.

Before testing, when turning on the two ESP8266 modules, their individual LEDs will blink and tell us they are in the pairing mode. At the moment when two chips stop blinking and are constantly on, pairing process is finished and they are already in connection.

During testing, the system's ability to maintain a stable connection and respond to button presses from the station module is evaluated. The key aspects checked include the latency of the response and the reliability of the connection under different conditions such as varying distances and potential physical obstructions that might impact wireless signal strength.

### **2.3.3 Design Alternatives**

The choice to use ESP8266 modules is based on their reliability, low cost, and built-in Wi-Fi capabilities, making them suitable for IoT projects that require wireless communication. The system design includes LEDs on both modules to provide immediate visual feedback regarding their connection status—blinking LEDs indicate that the devices are in pairing mode and searching for each other, while LEDs that remain constantly on signal a successful connection.

The use of UDP for communication between the two devices is justified by the protocol's simplicity and efficiency. UDP allows for faster transmission of messages compared to more complex protocols like TCP, which is essential for real-time applications like an alarm system where timely response is crucial. The choice to use physical buttons to trigger alarms ensures ease of operation, making the system accessible and straightforward for all users.

## **2.4 Demo Box**

### **2.4.1 Description:**

The demo box serves as a robust platform for showcasing the functionality of smoke alarms and hazardous gas alarms. As shown in Figure 8, crafted with precision, it stands at dimensions of 220mm in length, 220mm in width, and 300mm in height, providing ample space for demonstration purposes.

Constructed from laser-cut acrylic panels, the demo box boasts durability and transparency, allowing observers to witness the inner workings of the alarms. Its structural integrity is reinforced by 1720 aluminum corner connectors and M6 bolts and nuts, ensuring stability during demonstrations.

At the forefront of the demo box are strategically positioned manual call points, enabling easy access for initiating alarm demonstrations. These call points facilitate hands-on interaction, enhancing the learning experience for observers.

Integrated into the sealed cover of the demo box are smoke alarms and combustible gas alarms, securely fastened with bolts and nuts through the base. This arrangement ensures a secure and stable mounting, maintaining the integrity of the demonstration setup.

Located on the right side of the demo box is a handheld smoke machine, connected via 3D printed connectors for seamless integration. This smoke machine serves as a key component for simulating smoke emission, allowing for realistic demonstrations of alarm activation.

Completing the setup is an exhaust fan mounted on the backside of the demo box. Designed for efficient gas dispersal, the exhaust fan swiftly removes gas emissions from the enclosed space, ensuring safety and comfort during demonstrations.

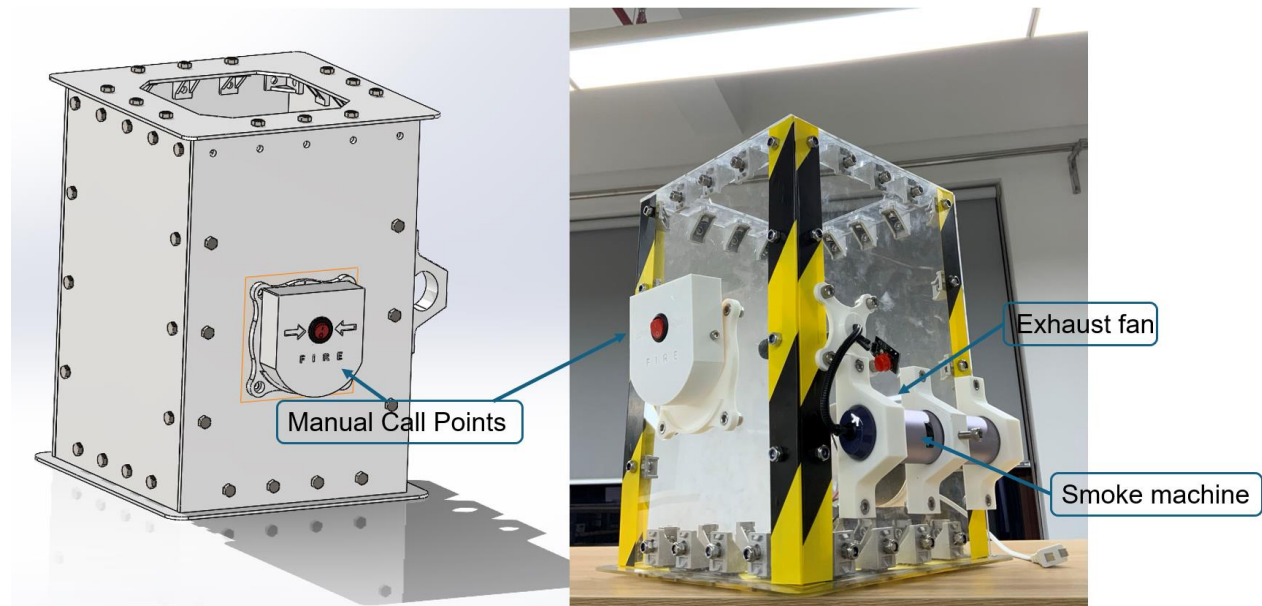

Figure 8 3D model diagram and exterior structure of the demo box

### 2.4.2 Design Alternatives

Smoke machine selection: The use of smoke generators such as cigarettes and biscuits on the display site is inappropriate because of the irritating odor and safety issues. Thus, smoke machine is used to demonstrate the effect of smoke alarms. The gas it produces is harmless and odorless and is mainly used in the production of special effects for films, which is suitable for this project.

## 3. Design Verification

In this section, the design verification of smoke alarms, combustible gas alarms, manual call points and battery power detection module will be discussed.

## 3.1 Verification of the Smoke Alarms

### 3.1.1 Experimental Design

According to the high-level requirements, the wireless connection between each device should be reliable, effective, and fast within a certain distance, and the sensitivity of the smoke sensor needs to be guaranteed. Therefore, we designed an experimental which aims to test the effectiveness and efficiency of smoke alarms in detecting smoke concentration accurately and transmitting wireless signals reliably. It is divided into two groups: one focusing on detecting smoke sensors, MQ-2, and the other on detecting temperature sensors, DHT11.

**Table 1 Different situations of smoke sensor and temperature sensor, DHT11**

Smoke sensor	DHT 11	Host computer	Specific Case
○	○	Alarm	There's a real fire.
○	×	No Alarm	Use of props such as dry ice.
×	○/×	No Alarm	The weather is unusually hot.

### 3.1.2 Experimental Procedures

1. Set up
  - a. Prepare the demo box with sealed covers containing smoke alarms.
  - b. Connect the smoke alarms to a terminal (laptop) for data display and monitoring, and the distance between them is around 10 meters.
2. Group #1
  - a. Set the threshold temperature on the terminal to 20 degrees Celsius to start the smoke alarm.
  - b. Observe the initial concentration value displayed on the terminal until it stabilizes.
  - c. Start the smoke machine to spray smoke into the demo box.
  - d. Record the time and specific value displayed on the terminal every 0.5 seconds.
  - e. Monitor if the smoke concentration reaches the threshold (300) and if the alarm is activated.
  - f. After the alarm activation, open the exhaust fan (around in 23s) to discharge the smoke completely within 10 seconds.
  - g. Continue monitoring the values displayed on the terminal every 2 seconds and record the response time and specific values.
  - h. Gradually increase the distance between the manual call points and audible and visual alarms in increments of 1 meter.
  - i. Record the maximum effective transmission distance at which the alarms are triggered reliably.
3. Group #2
  - a. Set the threshold temperature on the terminal to 50 degrees Celsius.
  - b. Repeat steps (b) to (g) from Group #1, replacing the smoke machine with monitoring the temperature rise in the demo box.
  - c. Note that the buzzer may not be triggered if the temperature does not reach the set threshold.
4. Data collection
  - a. Record the response time and wireless transmission time for both groups.
  - b. Document whether the alarm was activated and under what conditions.
  - c. Repeat the experiment multiple times to ensure consistency.



### 3.1.3 Experimental Result

Figure 9 shows the laptop display of smoke concentration over time, at the 9th second smoke machine is switched off and smoke starts spreading in the demo box, at the 18th second it reaches the threshold and smoke alarm starts alarming, at the 23rd second exhaust fan is switched on and the smoke concentration is starting to decrease with a delay of less than 1 second. The specific experimental phenomena are as follows:

1. Group #1: Smoke Sensors

Response time: Within 1 seconds

Wireless transmission time: Within 1 seconds

Alarm activation: Yes

2. Group #2: Temperature Sensors

Response time: Within 1 seconds

Wireless transmission time: Within 1 seconds

Alarm activation: No (Temperature did not reach 50 degrees Celsius)

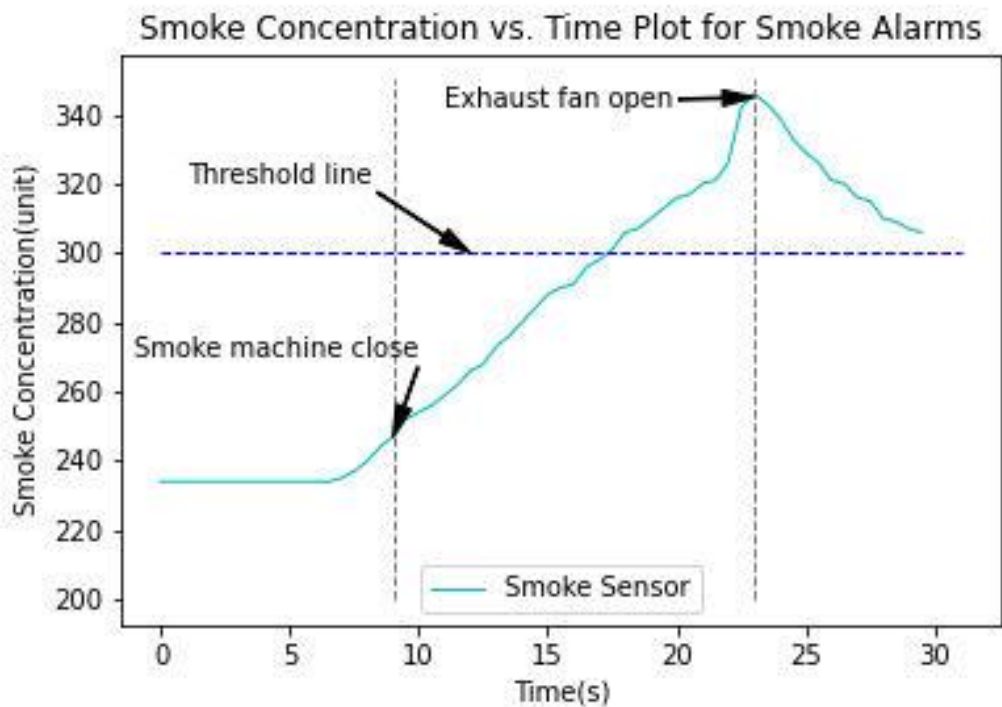

Figure 9 Smoke concentration vs. time plot



## 3.2 Verification of the Combustible Gas Alarm

### 3.1.1 Experimental Design

According to the high-level requirements, the wireless connection between each device should be reliable, effective, and fast within a certain distance, and the sensitivity of the combustible gas sensor needs to be guaranteed. Therefore, we designed an experimental which aims to test the effectiveness and efficiency of smoke alarms in detecting combustible gas concentration accurately and transmitting wireless signals reliably. It is divided into two groups: one focusing on detecting combustible gas sensors, MQ-5, and the other on detecting temperature sensors, DHT11.

**Table 2 Different situations of combustible gas sensor and temperature sensor, DHT11**

Combustible gas sensor	DHT 11	Host computer	Specific Case
○	○	Alarm	There's a real fire with combustible gas.
○	×	No Alarm	In a restaurant kitchen setting.
×	○/×	No Alarm	The weather is unusually hot.

### 3.1.2 Experimental Procedures

Same test procedure as in 3.1.2 for smoke alarms, with the only difference that the smoke machine is replaced by a gun capable of producing butane gas.

### 3.1.3 Experimental Results

Figure 10 shows the laptop display of combustible gas concentration over time, at the 6.5 second it reaches the threshold and combustible gas alarm starts alarming, at the 16 second exhaust fan is turned on and the combustible gas concentration is starting to decrease with a delay of less than 1 second. The specific experimental phenomena are as follows:

#### 1. Group #1: Combustible Gas Sensors

Response time: Within 1 seconds

Wireless transmission time: Within 1 seconds

Alarm activation: Yes

#### 2. Group #2: Temperature Sensors

Response time: Within 1 seconds

Wireless transmission time: Within 1 seconds

Alarm activation: No (Temperature did not reach 50 degrees Celsius)

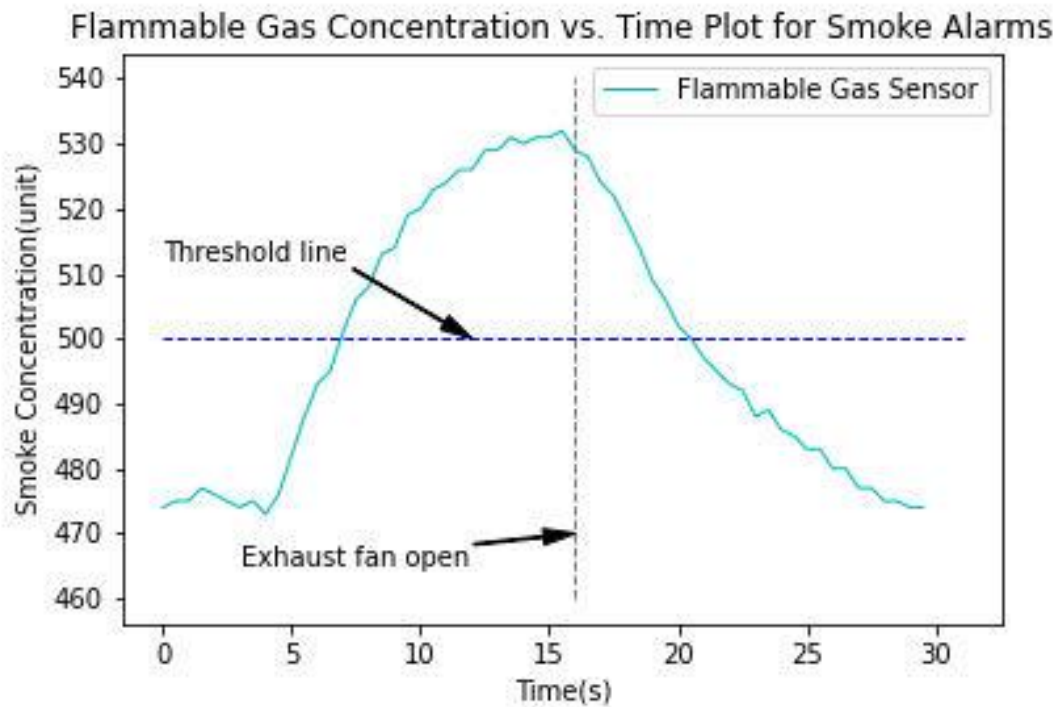

Figure 10 Combustible gas concentration vs. time plot

## 3.2 Verification of the Manual Call Points

### 3.2.1 Experimental Design

According to the high-level requirements, the wireless connection between each device should be reliable at a certain distance. Therefore, an experiment is designed to verify the effectiveness of signal transmission between the manual call points and audible and visual alarms at a certain distance. Three scenarios will be considered:

Case #1: Same floor environment without shade (simulating a laboratory environment).

Case #2: Same floor environment with two walls in the middle (simulating dormitory environment).

Case #3: Propagation between different floors.

Each case will measure the maximum effective transmission distance of the alarms and manual call points.

### 3.2.2 Experimental Procedures

5. Set up
  - a. Place the audible and visual alarms and manual call points in the designated locations for each case.
  - b. Ensure that the alarms and manual call points are properly configured and synchronized.

- c. Establish a baseline distance of 1 meter between the transmitter and receiver for calibration purposes.
6. Case #1
  - a. Place the manual call points in the designated location on the same floor without any obstruction.
  - b. Gradually increase the distance between the manual call points and audible and visual alarms in increments of 1 meter.
  - c. Record the maximum effective transmission distance at which the alarms are triggered reliably.
7. Case #2
  - a. Place the manual call points in the designated location on the same floor with two walls in between.
  - b. Repeat the same procedure as in Case #1, gradually increasing the distance between the manual call points and audible and visual alarms.
  - c. Record the maximum effective transmission distance considering the obstructed path.
8. Case #3
  - a. Place the manual call point in the designated location on one floor.
  - b. Place the audible and visual alarms on the adjacent floor.
  - c. Repeat the same procedure as in Case #1, gradually increasing the distance between the manual call points and audible and visual alarms.
  - d. Record the maximum effective propagation distance between different floors.
9. Data collection
  - a. Record the distances at which the alarms are triggered successfully.
  - b. Repeat each case three times to ensure consistency and reliability.
  - c. Average the results for each case to obtain the final maximum effective transmission distances.

### 3.2.3 Experimental Results

As shown in Figure 11, the experimental result is:

Case #1: Maximum effective transmission distance: 45 meters.

Case #2: Maximum effective transmission distance: 25 meters.

Case #3: Maximum effective propagation distance between floors: 3 meters.

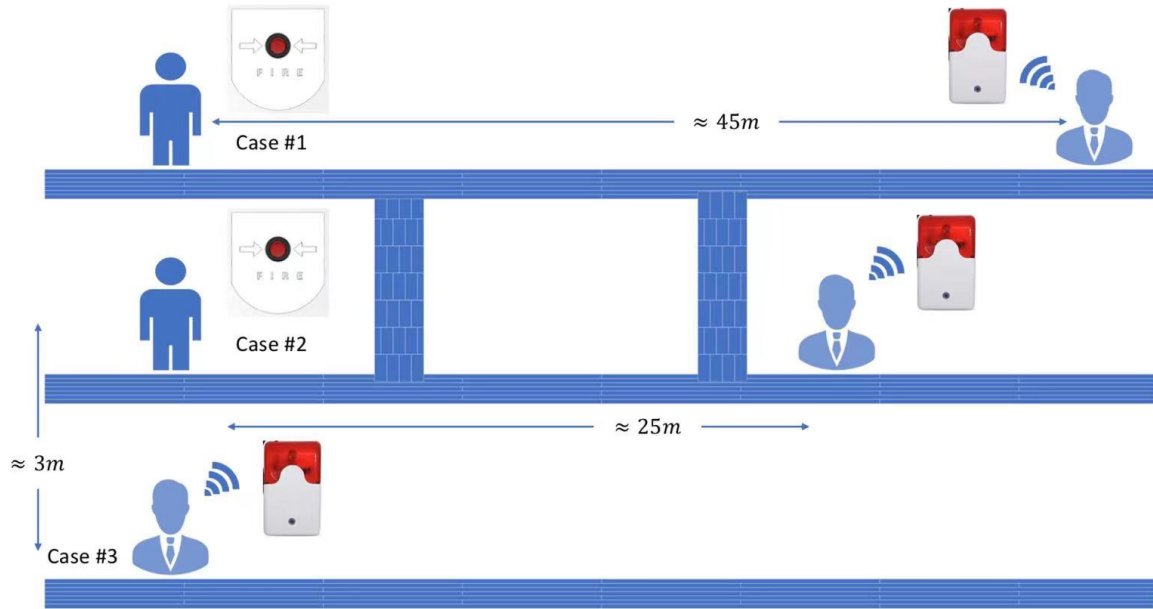

Figure 11 Result diagram of the verification of the manual call points

### 3.3 Verification of the Functionality of a Battery Power Detection Module

#### 3.3.1 Experimental Design

According to the high-level requirements, the battery power should be detected timely. The experiment aims to verify the functionality of a battery power detection module. It is divided into two groups: one with batteries exhibiting sufficient power and the other with batteries exhibiting insufficient power. The battery power detection module triggers an LED color change from green to red when the voltage drops below 5V.

#### 3.3.2 Experimental Procedures

1. Set up
  - a. Gather the battery power detection module, batteries, oscilloscope, and LED.
  - b. Connect the battery power detection module to the oscilloscope to monitor voltage readings.
2. Group division
  - a. Prepare 4 AAA batteries with sufficient power to maintain a voltage reading of 5.8V on the oscilloscope.
  - b. Prepare 4 AAA batteries with insufficient power to maintain a voltage reading of only 3.7V on the oscilloscope.
3. Testing
  - a. Connect the batteries with sufficient power to the battery power detection module.
  - b. Observe the LED color. It should initially be green.
  - c. Connect the batteries with insufficient power to the battery power detection module.
  - d. Observe the LED color. It should initially be green if the battery power is above the threshold or red if it is below.

#### 4. Data collection

- a. Record the LED color observed for each group.
- b. Repeat the procedure multiple times to ensure consistency.

### **3.3.3 Experimental Results**

As shown in Figure x, the experimental result is:

Group 1 (Sufficient Power): LED color observed: Green.

Group 2 (Insufficient Power): LED color observed: Red.

## 4. Costs

### 4.1 Parts

Table 3 Parts Costs

Part	Manufacturer	Retail Cost (\$)	Bulk Purchase Cost (\$)	Actual Cost (\$)
Handheld Smoke Machine	Selens	42.7	42.7	42.7
PCB	Jialichuang EDA	5.14	5.14	25.7
ESP 8266 CP2102 Chips	Zejie Flagship Store	2.84	2.84	14.2
M6*12 Bolts	Tianzhuo Hardware Co.	0.16	0.10	10.0
M6 Nuts	Tianzhuo Hardware Co.	0.16	0.10	10.0
1720 Aluminum Corner Connector	Jianen Aluminum Profiles Co.	0.18	0.12	7.2
AAA Battery	Nanfu	0.35	0.35	5.7
Exhaust Fan	Ppwq	4.27	4.27	4.3
M4*6Bolts	Tianzhuo Hardware Co.	0.15	0.08	4.0
M4 Nuts	Tianzhuo Hardware Co.	0.15	0.08	4.0
Voltage Detection Lamp Board	Yixin Circuit Design Co.	0.86	0.86	3.4
Audible and Visual Alarms	Kariful	2.14	2.14	4.28
Sealed Covers	Xiongchuang Furniture Plastic Fittings Factory	1.71	1.71	1.71
AAA Battery Holder	Xinwei	0.21	0.21	1.26
DHT 11 Temperature Sensor	Touglesy	0.55	0.55	1.1
MQ-5 Combustible Gas sensor	Touglesy	0.94	0.94	0.94
MQ-2 Smoke Sensor	Touglesy	0.94	0.94	0.94
Switch	Haique Digital Store	0.066	0.066	0.66
<b>Total</b>				<b>\$ 142.09</b>

### 4.2 Labor

Our fixed development costs are estimated to be \$25/hour, 10 hours/week for three people. We consider approximately 60% of our final design in this semester (16 weeks), neglecting the central server, mesh network optimization, and partnerships with NGOs:

$$4 \cdot \frac{\$25}{hr} \cdot \frac{10 hr}{wk} \cdot \frac{16 wks}{0.6} \cdot 2.5 = \$66,666 \quad \text{Eq. 1}$$

## 5. Schedule

**Table 4 Weekly Team Schedule**

<b>Date</b>	<b>Xiaohua Ding</b>	<b>Jiawei Zhu</b>	<b>Honglei Zhu</b>
Week 1	Discuss the details of the project	Project discussion	Discussion of the project
Week 2	RFA	Preliminary project schedule	RFA
Week 3	3D model of the smoke alarms	Arduino environment setup	Arduino learning
Week 4	Project proposal	Sensor setup & connection	Sensor selection and testing
Week 5	Modify the 3D model of the smoke alarms	Integration of combustible gas and temperature sensors	Temperature and Humidity Sensor Testing
Week 6	Purchase some relative materials and print the 3D models	Functional testing of sensors	Circuit design and construction
Week 7	Complete the design document	Building manual call points	Device Networking Programming
Week 8	Complete the assembly of smoke alarms	Integration of audible and visual alarm with push button module	Mobile data display test
Week 9	Complete the assembly of manual call points and audible and visual alarms	Web display	Web display
Week 10	3D model of the demo box and purchase some relative material	Connection of web and hardware	Programming of silencing operations
Week 11	Complete demo box	Soldering	PCB design & PCB printing
Week 12	Fix fire alarms and mock demo	Functional testing of all modules	Component Soldering
Week 13	Final report and prepare final demo and final presentation	Final Report & final demo	Functional testing of all modulese

## 6. Conclusion

### 6.1 Accomplishments

Combining smoke sensors, combustible gas detectors, manual alarm buttons, and audible and visual alarms, the smart firefighting ecosystem can realize comprehensive safety monitoring of public areas such as residential communities and shopping malls. For public spaces, the system monitors the smoke concentration in the air through wireless smoke sensors, which instantly send out an alarm signal once the value exceeds 400 and the accompanying temperature rises above 50 degrees Celsius. For kitchen scenarios in the home, a combustible gas detector also triggers an alarm when the gas concentration exceeds 300 and the temperature reaches 50 degrees Celsius, doubly guaranteeing early detection of fire. In addition, the manual alarm button provides a means of emergency intervention for site personnel. Once pressed, the audible and visual alarms emit a distinctive alarm signal to alert site personnel to react quickly. All alarm information is quickly transmitted to the fire protection data platform via a wireless network, enabling immediate remote monitoring and response. The need to be able to eliminate the traditional fire protection system in the cumbersome wiring work, making the installation process easier and faster, and can be used to stabilize the work of the battery.

### 6.2 Uncertainties

#### 6.2.1 Smoke sensors & combustible gas detectors

For smoke sensors and combustible gas detectors placed in the demo box for testing. If the sensor fails to detect changes in smoke or gas concentrations in real time, possible reasons include:

1. The sensor itself may be damaged and not responding properly to the presence of smoke or gas.
2. The IoT module may have failed to successfully connect to the network, preventing sensor data from being transmitted to the monitoring platform.
3. The sensor's circuit connections may have weak soldering or poor contact, affecting signal transmission.

When the sensor detects the smoke or combustible gas value reaches the set condition, and the temperature rises to the set condition. If the sensor fails to signal an alarm, possible causes include:

1. The alarm buzzer may be damaged and not functioning properly.
2. The power supply to the sensor may be insufficient, e.g. the battery is low, resulting in failure to trigger the alarm mechanism.
3. The sensor's internal circuitry may be faulty, such as a weak solder, which interferes with its normal function.

When the sensor sends out an alarm signal, the silencing operation is performed through the fire data platform on the computer side. If the silencing operation is not successfully executed, possible reasons include:



1. The network connection is unstable, resulting in the platform's silencing command not being conveyed to the sensor in time.
2. The fire data platform may have technical faults or server response delays that affect the processing of silencing commands.

### **6.2.2 Audible and visual alarms and manual call points**

When the manual call points are pressed at close range and the audible and visual alarms do not sound, possible problems include:

1. damage to the combustible gas sensor or the DHT11 temperature and humidity module, causing the system to fail to recognize the alarm condition correctly.
2. The ESP8266 IoT module may fail to successfully link to the network, resulting in the alarm signal not being transmitted.
3. Circuit connections may have false soldering, resulting in interrupted or unstable signal transmission.

When the manual call points are placed at a distance of 30 meters from an unobstructed object and the button is pressed, the audible and visual alarms do not sound. Possible problems include.

1. a damaged buzzer that fails to sound.
2. The batteries are low, preventing the audible and visual alarms from functioning properly.
3. There is a false solder in the circuit connection, which affects the activation of the alarm.

When two manual call points are pressed at 25 meters and is covered by two walls, if the audible and visual alarm does not sound, the possible problems are the same as in the second point and the signal transmission may be interfered with by the walls.

When a manual alarm button is pressed and fails to linkage activate multiple audible and visual alarms, possible problems include:

1. Incompatible or misconfigured communication protocols between IoT modules, resulting in failure to achieve linkage.
2. There may be problems with the linkage logic settings of the fire data platform, and the linkage settings of the platform need to be checked and adjusted.
3. The receiver module of the sound and light alarm may be faulty and unable to receive signals from the manual alarm button.

### **6.3 Ethical considerations**

Because our ESP 8266 CP2102 chip ultimately needs to rely on the software platform on the mobile terminal to link with the fire protection equipment we designed, the use of intelligent fire protection

equipment and software may collect and transmit sensitive data, such as location information, environmental parameters, and so on. According to the IEEE Code of Ethics, #1[5], "to protect the privacy of others, and to disclose promptly factors that might endanger the public or the environment." The design process should ensure that the privacy of user data is protected from unauthorized access and data leakage, and that users are informed about how data is collected, used, and protected.

Regarding the new design of smoke alarms, push button alarms and audible and visual alarms, these products need to comply with the Chinese standard for self-contained smoke alarms: GB 20517-2006[6], which has provisions for high temperature and corrosion resistance, so polyvinyl chloride (PVC) material is used in the official products to meet the requirements and to facilitate the manufacture and reduce the cost.

Unfortunately, PVC is hazardous to the environment and is a difficult material to degrade. In order to meet the IEEE Code of Ethics, #1[5], "to hold paramount, the safety, health, and welfare of the public, to strive to comply with ethical design and sustainable We believe that equipment should be manufactured and used in a way that minimizes its impact on the environment. We believe that equipment should be manufactured and used in a way that minimizes its impact on the environment. For example, we need to use environmentally friendly materials and manufacturing processes for packaging, and modular designs that allow for easy disassembly and replacement of components, as well as ensuring that the equipment can be safely recycled at the end of its lifecycle.

According to our opinion and design, our products do not exist with race, religion, gender, disability, age, national origin, sexual orientation gender identity, or gender expression, which is mentioned in the IEEE Code of Ethics, #7[5].

## 6.4 Future work

In the future, our intelligent fire protection system can also realize intelligent linkage with other fire protection equipment (such as automatic sprinkler systems, fire doors, smoke exhaust systems, etc.), so that once a fire occurs, the relevant fire protection facilities will be activated automatically. We hope to combine monitoring equipment and firefighting equipment. The system supports remote call monitoring function, so that safety management personnel can view the sensor status and monitoring video in real time through the Internet and realize accurate judgment of the real situation of fire.

The system can also be able to record changes in environmental parameters and alarm events, providing data support for after-action analysis and the development of preventive measures. In order to improve the stability and reliability of the system, it is necessary to increase the self-test and maintenance tips of the fire equipment, which can regularly check the status of the equipment and remind the user to carry out the necessary maintenance through alarms or prompt messages.

## References

- [1] J. Pritzker, "the 2022 annual report for the office of the Illinois state fire mar-shal," vol. 32, p. 31, Feb. 2023.
- [2] A. Cowlard, A. Bittern, C. Abecassis-Empis, and J. Torero, "Fire safety design for tall buildings," *Procedia Engineering*, vol. 62, pp. 169–181, 2013.
- [3] J. Ma, W. Song, W. Tian, S. M. Lo, and G. Liao, "Experimental study on an ultra-high-rise building evacuation in China," *Safety science*, vol. 50, no. 8, pp.1665–1674, 2012.
- [4] J. Nie and H. Du, "Overview of specialized smoke detector detection circuits," vol. 12, no. 06, pp. 39–41+46, 2012.
- [5] IEEE.org, "IEEE code of ethics," 2020. [Online]. Avail-able: <https://www.ieee.org/content/dam/ieee-org/ieee/web/org/about/corporate/ieee-code-of-ethics.pdf> .
- [6] General Administration of Quality Supervision, Inspection and Quarantine of the People’s Republic of China, Standardization Administration of the People’s Republic of China, "National standard of the people’s republic of China fire detection and alarm systems-smoke alarms," 2006. [Online]. Available: <https://openstd.samr.gov.cn/bzqk/gb/newGbInfo?hcno=11BFFB6E7366D62926036872F2DEC1BA4>
- [7] S. Al Kuran, "The prospects for GaAs MESFET technology in dc–ac voltage conversion," in *Proceedings of the Fourteenth Annual Portable Design Conference*, 2010, pp. 137-142.
- [8] K. E. Elliott and C. M. Greene, "A local adaptive protocol," Argonne National Laboratory, Argonne, IL, Tech. Rep. 916-1010-BB, 2006.
- [9] J. Groepelhaus, "Java 5.7 tutorial: Design of a full adder," class notes for ECE 290, Department of Electrical and Computer Engineering, University of Illinois at Urbana-Champaign, 2011.
- [10] Ministry of Public Security of the People’s Republic of China, "Code for design of automatic fire alarm system:gb50116-2013," 2013. [Online]. Available: [https://js.119.gov.cn/202111/206aeb848d24575894f22639ff3e721\\_c\\_0535ace6ae86458fa1cf.html](https://js.119.gov.cn/202111/206aeb848d24575894f22639ff3e721_c_0535ace6ae86458fa1cf.html)
- [11] Q. Tang, "Design and practice of smoke alarms supporting metro lora iot private networks," *Internet of Things technology*, vol. 10, no. 07, pp. 12–15, 2020.
- [12] L. Jun, "Principles and applications of smoke alarms," *Chinese security*, no. 22, p. 2, 2013.

## Appendix A Requirement and Verification Table

**Table 5 System Requirements and Verifications**

Requirement	Verification	Verification status (Y or N)
<p>1. Requirement of Combustible Gas Alarms Subsystem</p> <ul style="list-style-type: none"> <li>a. When the combustible gas in-tensity changes, the app can display intensity value.</li> <li>b. When the combustible gas in-tensity changes, the app can display intensity value.</li> <li>c. When the combustible gas in-tensity reaches the threshold value (around 500), the buzzer triggers.</li> <li>d. When the temperature reaches the threshold value, the buzzer triggers.</li> </ul>	<p>1. Verification</p> <ul style="list-style-type: none"> <li>a. Use lighter to simulate a fire, satisfy both combustible gas and temperature requirements.</li> <li>b. After the alarm is triggered, we manually eliminate the alarm through the computer.</li> </ul>	Y
<p>2. Requirement of Smoke Alarms Subsystem</p> <ul style="list-style-type: none"> <li>a. When the smoke concentration changes at the scene, the cell phone can display the smoke concentration in real time.</li> <li>b. When the temperature of the scene changes, the cell phone can display the temperature in real time.</li> <li>c. When the smoke concentration reaches a certain value (60%)[6,10], the buzzer starts to sound the alarm.</li> <li>d. The computer can get the alarm information, if it is a false alarm, you can eliminate the alarm remotely through the cell phone[11].</li> </ul>	<p>2. Verification</p> <ul style="list-style-type: none"> <li>a. Use the smoke produced by cigarettes to spray to the smoke sensor, observe whether the smoke concentration and temperature on the cell phone display and change[12].</li> <li>b. When the smoke concentration reaches a certain value, the buzzer pin receives a high electric frequency, buzzer alarm.</li> <li>c. When the smoke concentration exceeds the standard and the buzzer continues to alarm, press the mute button on the cell phone to determine whether it can be remotely silenced.</li> </ul>	Y
<p>3. Requirement of Manual Call Points subsystem</p> <ul style="list-style-type: none"> <li>a. Manually push the button to trigger alarm signal to trigger alarm in another</li> </ul>	<p>3. Verification</p> <ul style="list-style-type: none"> <li>a. Try pressing the manual alarm button at different distances and observe if the audible and visual alarms</li> </ul>	Y

separate esp8266 Audible and visual alarm module.	alarm.	
<p>4. Requirement of Audible and Visual Alarm subsystem</p> <p>a. Wireless communication with the Manual Call Points System and alarm function</p>	<p>4. Verification</p> <p>a. Try pressing the manual alarm button at different distances and observe if the audible and visual alarms alarm.</p>	Y

## Appendix B PCB Layout

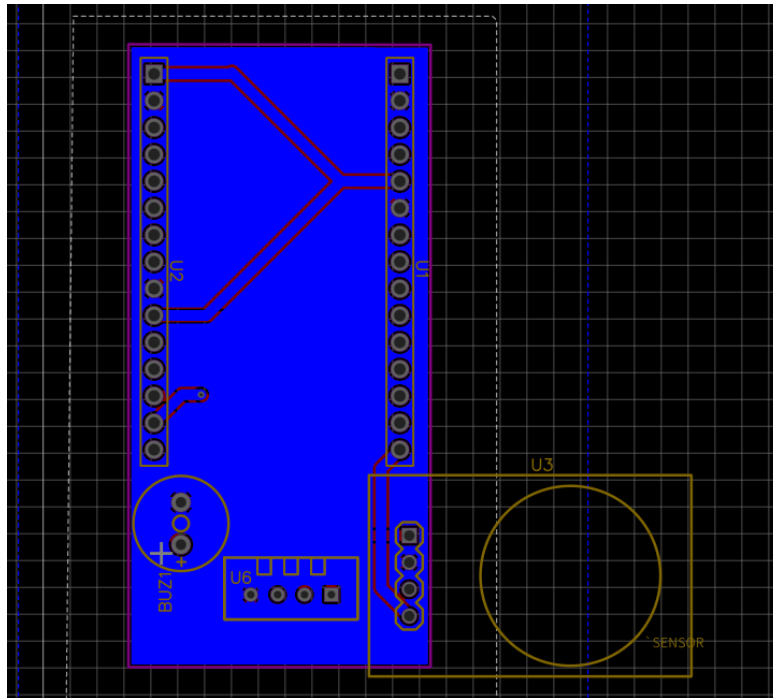

Figure 12 PCB Layout

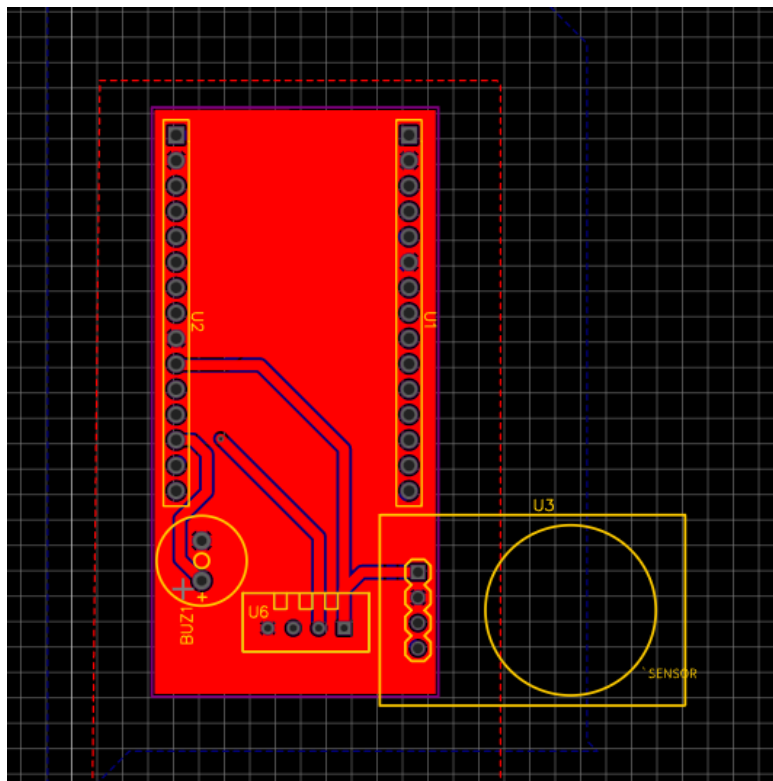

Figure 13 PCB Layout (Reverse side)

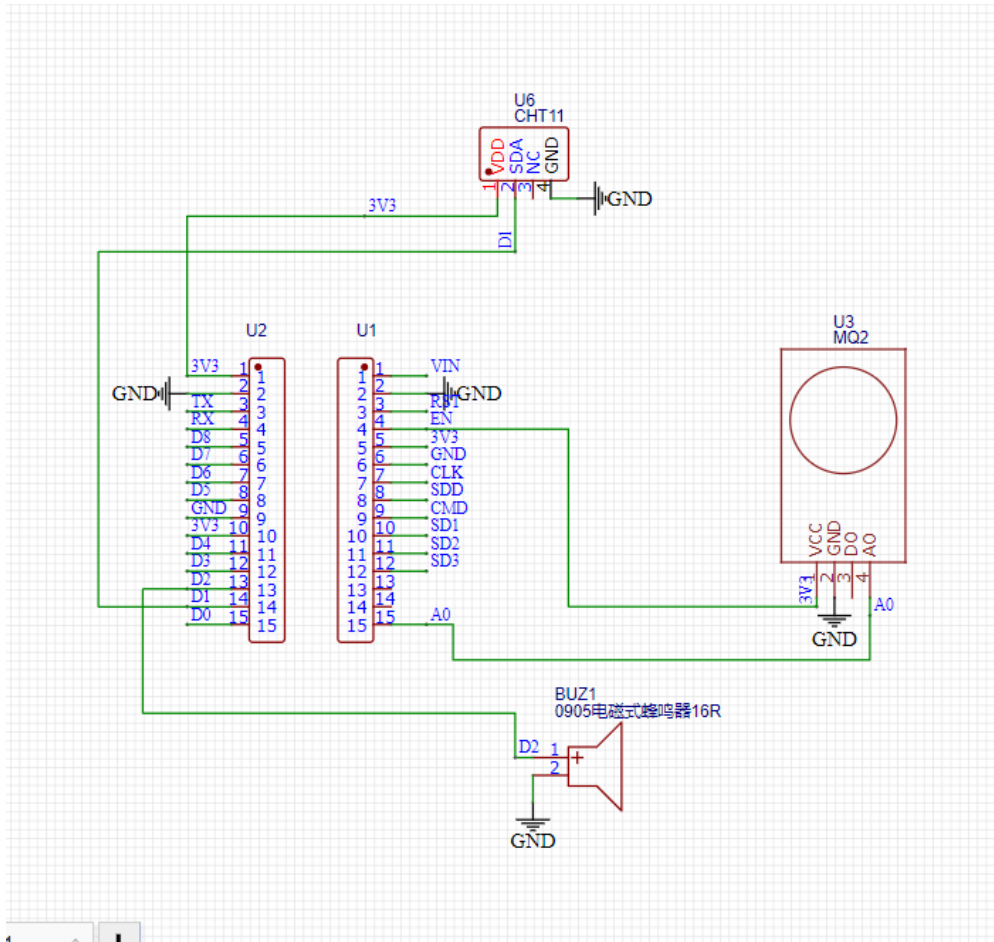

Figure 14 PCB Schematic