

ZJU–UIUCInstitute

ME470/ECE445

FinalReport

---

# Continuous Roll-To-Roll LB Film Deposition Machine

---

By

Boyang Fang

(boyangf2@illinois.edu)

Han Li

(hanl8@illinois.edu)

Ruiqi Zhao

(ruiqiz6@illinois.edu)

Zhixian Zuo

(zhixian3@illinois.edu)

Supervisor: Prof. Kemal Celebi

TA: Zhanyu Shen

2024-5-10

# CONTENTS

<b>1. INTRODUCTION .....</b>	<b>1</b>
1.1 PURPOSE .....	1
1.1.1 <i>Background</i> .....	1
1.1.2 <i>Problem</i> .....	1
1.1.3 <i>Solution</i> .....	2
1.2 FUNCTIONALITY .....	2
1.3 SUBSYSTEM OVERVIEW .....	3
1.3.1 <i>Figures and block diagrams of subsystems.</i> .....	3
<b>2. DESIGN .....</b>	<b>5</b>
2.3 CALCULATION AND SIMULATION .....	5
2.3.1 <i>Speed and Throughput</i> .....	5
2.3.2 <i>Consumption</i> .....	5
2.3.3 <i>The relationship between film deposition Angle and horizontal distance of tank</i> .....	7
2.2 DESIGN ALTERNATIVES .....	8
2.3 DESIGN DESCRIPTION & JUSTIFICATION .....	9
2.4 SUBSYSTEM DIAGRAMS & SCHEMATICS .....	11
2.4.1 <i>Transmission subsystem</i> .....	11
2.4.2 <i>Material injection subsystem</i> .....	12
2.4.3 <i>Diffusion trough subsystem</i> .....	13
2.4.4 <i>Power system</i> .....	14
2.4.4.1 <i>Image processing subsystem</i> .....	14
2.4.4.2 <i>Electric control subsystem</i> .....	15
<b>3. COST &amp; SCHEDULE.....</b>	<b>15</b>
3.1 COST ANALYSIS .....	15
3.2 SCHEDULE .....	15
<b>4. REQUIREMENTS &amp; VERIFICATION.....</b>	<b>16</b>
4.1 COMPLETENESS OF REQUIREMENTS & APPROPRIATE VERIFICATION PROCEDURES .....	16
4.1.1 <i>Power subsystem</i> .....	16
4.1.1.1 <i>Electric control system</i> .....	16
4.1.1.2 <i>Image processing subsystem</i> .....	17
4.1.2 <i>Transmission subsystem</i> .....	18
4.1.3 <i>Deposition tank subsystem</i> .....	18
4.1.4 <i>Injection material subsystem</i> .....	19
4.1.5 <i>Tolerance Analysis</i> .....	20
4.2 QUANTITATIVE RESULTS.....	20
4.3 RESULT .....	21
<b>5. CONCLUSION .....</b>	<b>22</b>
5.1 ACCOMPLISHMENTS.....	22
5.2 UNCERTAINTIES.....	23
5.3 FUTURE WORK / ALTERNATIVES .....	23
5.4 ETHICAL CONSIDERATIONS.....	24
5.4.1 <i>Ethics</i> .....	24
5.4.2 <i>Safety</i> .....	24
<b>6. REFERENCE .....</b>	<b>26</b>

# 1. Introduction

## 1.1 Purpose

This project aims to develop an instrument based on Langmuir-Blodgett (LB) coating technology, utilizing a Roll-To-Roll dual-roller structure. This innovative approach seeks to enable sustainable production of nanofilms, significantly enhancing production efficiency and film quality compared to traditional LB film production methods.

### 1.1.1 Background

Langmuir-Blodgett (LB) coating technology, developed in the early 20th century by scientists such as Irving Langmuir and Katherine Blodgett, is a well-established method for precise deposition of molecular layers onto solid substrates from a water surface. This technique is crucial in materials science and surface science due to its ability to control molecular arrangement and orientation with high precision.

The recent surge in demand for LB coating technology is driven by the increasing utilization of nanomaterials in ultrathin coatings. Nanomaterials offer unique physical and chemical properties that enhance the functionalities and performance of coatings, making LB coating a critical tool in nanomaterial research and applications.

The advantages of LB coating technology combined with nanomaterials include:

**Precise Control:** LB coating enables meticulous control over the arrangement and orientation of nanomaterials, facilitating tailored coating properties essential for various applications, such as optimizing conductivity in electronics or adjusting optical properties in photonics.

**Uniformity:** LB coating produces highly ordered and uniform thin films, crucial for applications like enhancing sensor sensitivity or improving biocompatibility in biomedical devices.

**Nanoscale Thin Films:** LB coating can create nanoscale thin films, allowing for the production of nanoelectrodes in nanoelectronics or thin films with unique optical properties in nanophononics.

**Scalability:** While traditional LB coating faces challenges, advancements in process and technology can potentially scale up LB coating for large-area manufacturing, providing an effective solution for utilizing nanomaterials in ultrathin coatings. Based on this background, this project aims to develop a Continuous Roll-To-Roll Thin Film Deposition Machine based on LB coating technology. Through innovative design and technology, the machine seeks to achieve efficient production and application of nanomaterials, thereby advancing the use and industrialization of nanomaterials in ultrathin coatings.

The application of Langmuir-Blodgett (LB) coating technology has significantly enhanced the performance of material surfaces. Its precise control over molecular layers enables researchers to design and fabricate more complex and efficient nanomaterials, thereby advancing the fields of material science and nanotechnology.

### 1.1.2 Problem

Traditional LB coating techniques face challenges with low production efficiency and limitations in scaling up for large-area manufacturing. Traditional LB coating techniques encounter challenges such as limited production efficiency and scalability for large area manufacturing. These limitations arise from the manual or rudimentary mechanical processes typically used in traditional LB coating, which are inefficient for large-scale production. Additionally, the technique's reliance on water surfaces imposes constraints on coating size,

making it difficult to scale up for large-area manufacturing applications. Furthermore, traditional LB coating processes struggle with quality control, often resulting in uneven coating thicknesses or the formation of bubbles. As the demand for nanomaterials in ultrathin coatings grows, traditional LB coating techniques face increasing challenges that necessitate improvements in production efficiency, quality control capabilities, and scalability.

### **1.1.3 Solution**

Existing solutions for thin film deposition, such as commercial Roll-To-Roll (R2R) machines, often require the use of barriers to prevent contamination and maintain film integrity. However, this reliance on barriers hinders scalability by adding complexity and cost to the manufacturing process. Therefore, there is a growing need for alternative thin film deposition techniques that can achieve scalability without the need for barriers.

To address this challenge, this project aims to overcome the limitations of traditional LB film production, opening new avenues for the commercialization and practical application of LB films.

To address this challenge, this project aims to overcome the limitations of traditional LB film production, opening new avenues for the commercialization and practical application of LB films.

## **1.2 Functionality**

### **The efficiency of material self-spreading:**

Achieving uniform spreading of materials on a substrate is crucial for consistent film properties. Effective self-spreading ensures film uniformity, directly impacting its performance in various applications. Techniques such as using moving water can enhance distribution and quality, ensuring a more even coating.

### **The selection of high-quality Teflon:**

The choice of high-quality Teflon as the trough material is critical for effective thin film deposition processes. Teflon's exceptional chemical resistance ensures compatibility with a wide range of solvents and chemicals commonly used in these processes. Its low surface energy prevents material adherence to the trough walls, facilitating uniform film deposition on the substrate. Teflon's smooth surface reduces friction, enabling smooth substrate movement for even material spreading. Additionally, Teflon's high temperature resistance allows for the deposition process to be conducted at elevated temperatures without compromising material integrity.

### **The stretched drawing of the polymer film substrate:**

The stretching and drawing of the polymer film substrate play a crucial role in thin film deposition processes. Stretching the substrate can align polymer chains and increase crystallinity, enhancing the mechanical and barrier properties of the final film. Drawing the substrate further orients the polymer chains, improving the film's strength and flexibility. Additionally, stretching and drawing can reduce the substrate's thickness, enabling the deposition of thinner films. This process can be controlled to achieve the desired mechanical, barrier, and optical properties of the final film.

### 1.3 Subsystem overview

This section gives the description of all subsystem functions and interaction with other subsystems.

#### 1.3.1 Figures and block diagrams of subsystems.

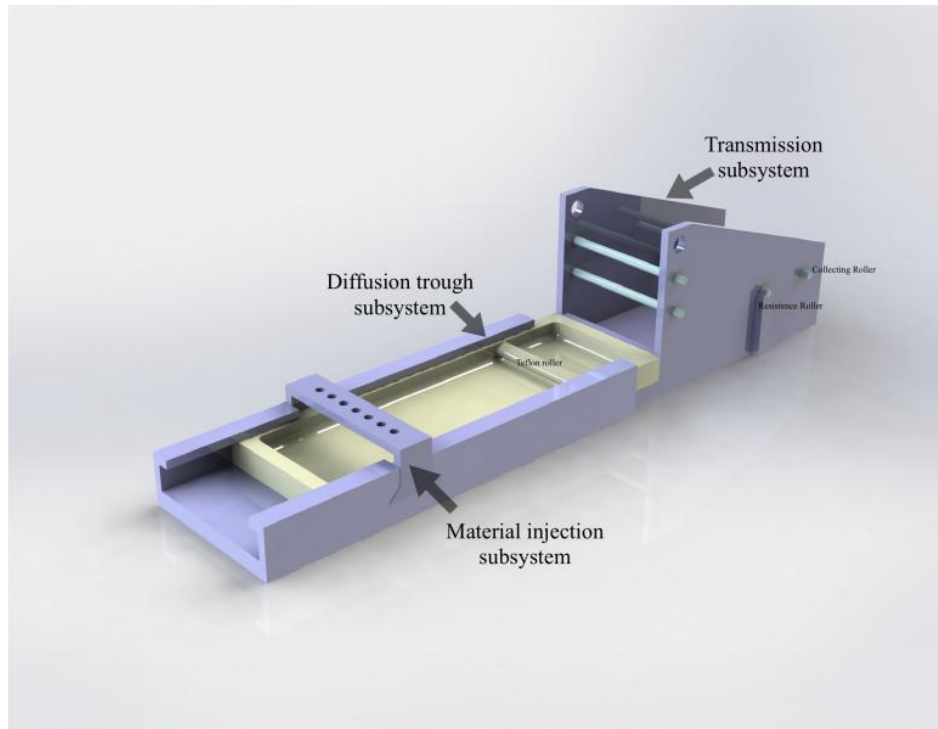

Figure1. Detailed design sketches for assembly completion

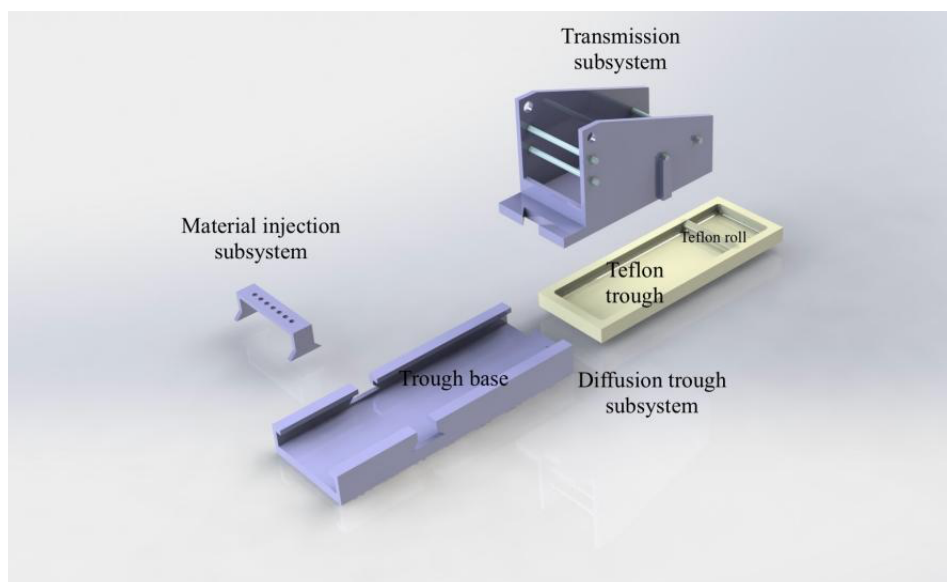

Figure2. Detailed sketch of unassembled design

These two figures provide the overview about the transmission subsystems and material injection subsystem and diffusion trough subsystem, and their relationships are shown below.

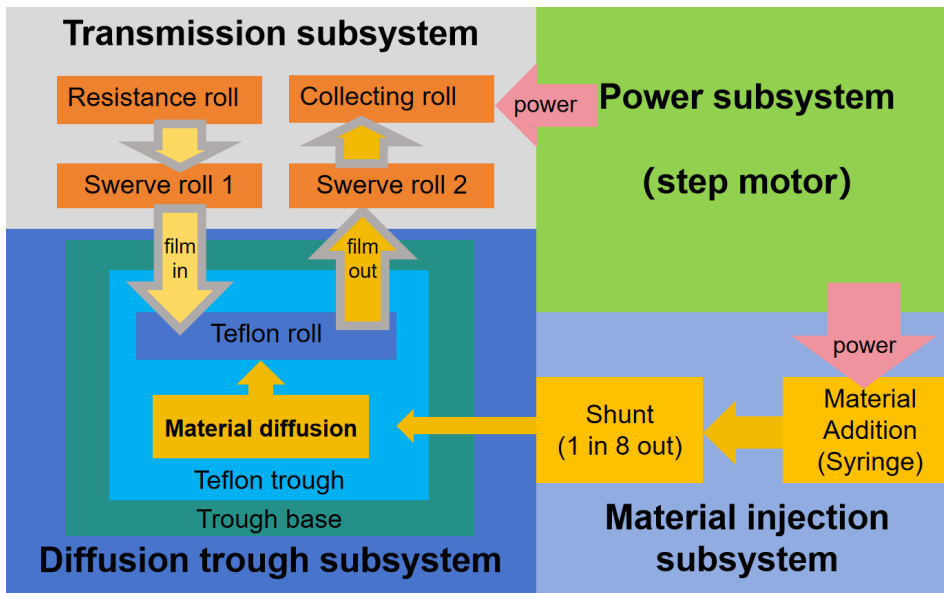

Figure3. Block diagram about the relationship among subsystems

In our project, the core of the power subsystem is the stepper motor, which drives the transmission subsystem and the material injection subsystem. The material is directly dripped into the diffusion trough subsystem, and after several steps, it finally reaches the Teflon roll. Additionally, the Teflon roll interacts with the transmission subsystem for control. Ultimately, the combination of these four subsystems constitutes the entire project.

The power subsystem consists of two parts: the image processing system and the electric control system. The image processing system judges the quality of the film based on the proportion of the available area of the film that has been coated. It provides feedback to the electric control system regarding the quality of the film. The electric control system, driven by Arduino and TB6600 drivers, primarily controls the motor's speed.

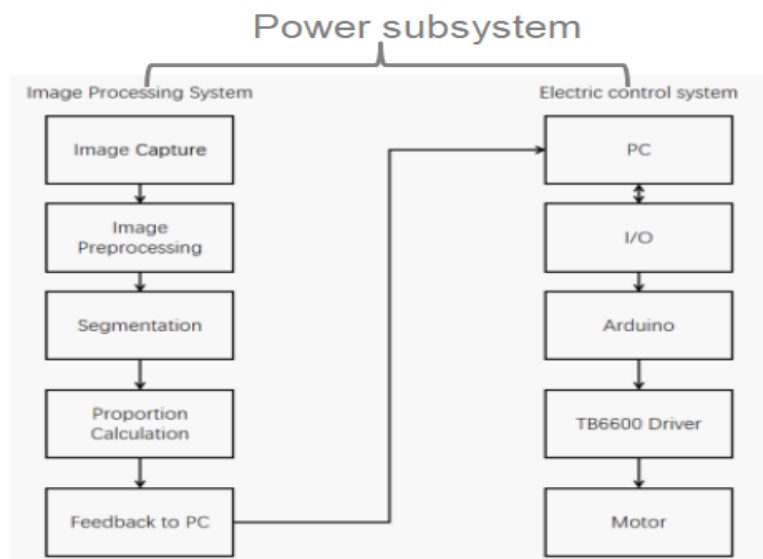

Figure4. Block diagram of power system which contains electric control system and image processing subsystem

## 2.Design

### 2.3 Calculation and Simulation

The design and development of a Langmuir-Blodgett (LB) roll-to-roll (R2R) machine for the continuous production of nanofilms represent a significant advancement in thin film deposition technology. This section presents a detailed description of the calculation and simulation methods employed in the design process, focusing on critical aspects.

#### 2.3.1 Speed and Throughput

The speed of the R2R system directly affects the throughput and film quality. The optimal speed can be determined based on the transfer rate of the monolayers, substrate size, and drying time. The throughput (Q) can be calculated using the formula:

$$Q = V \times W \times d$$

Where:

- Q is the throughput (m/s).
- V is the speed of the R2R system (m/s).
- d is the width of the substrate (m).

The relationship between the film running speed (V) and the stepper motor can be determined by considering the gear ratio of the stepper motor system. Let's denote the pitch of the gear as P and the diameter of the gear as D. The linear speed of the gear (v) can be calculated as:

$$v = \frac{2\pi r}{T}$$

Where:

- r is the radius of the gear (m).
- T is the period of one step of the stepper motor (s).

Assuming the gear has a pitch diameter of D and a pitch of P, the radius of the gear can be approximated as  $r = \frac{D}{2}$ . The period of one step of the stepper motor (T) can be calculated as  $T = \frac{1}{f}$ , where f is the stepping frequency of the motor. Thus, the relationship between the film running speed and the stepper motor can be expressed as:

$$V = \frac{2\pi \times \frac{D}{2}}{\frac{1}{f}} = \pi \cdot D \cdot f$$

Where:

- f is the frequency of one step of the stepper motor (Hz).

#### 2.3.2 Consumption

The energy consumption of the LB R2R machine is a critical factor in its design and operation. It can be estimated by considering the power requirements of the motors, heaters, and other components. The total energy consumption (E) can be calculated as:

$$E = P \times t$$

Where:

- E is the total energy consumption (J)
- P is the power consumption per unit time (W).
- t is the operating time (s).

For a stepper motor, the work done can be approximated as the torque ( $\tau$ ) produced by the motor multiplied by the angular displacement ( $\theta$ ) per unit time. Therefore, the power consumption of the stepper motor can be expressed as:

$$P = \tau \times \omega$$

Where:

- $\tau$  is the torque (N·m),
- $\omega$  is the angular velocity (rad/s).

The torque required to drive the system can be calculated using the formula:

$$\tau = F \times r$$

Where:

- F is the force required to drive the system (N).
- r is the radius of the gear (m).

Substituting the expressions for torque ( $\tau$ ) and angular velocity ( $\omega$ ) into the power consumption formula, we get:

$$P = F \times r \times 2\pi f$$

Where:

- f is the stepping frequency of the motor (Hz).



### 2.3.3 The relationship between film deposition Angle and horizontal distance of tank

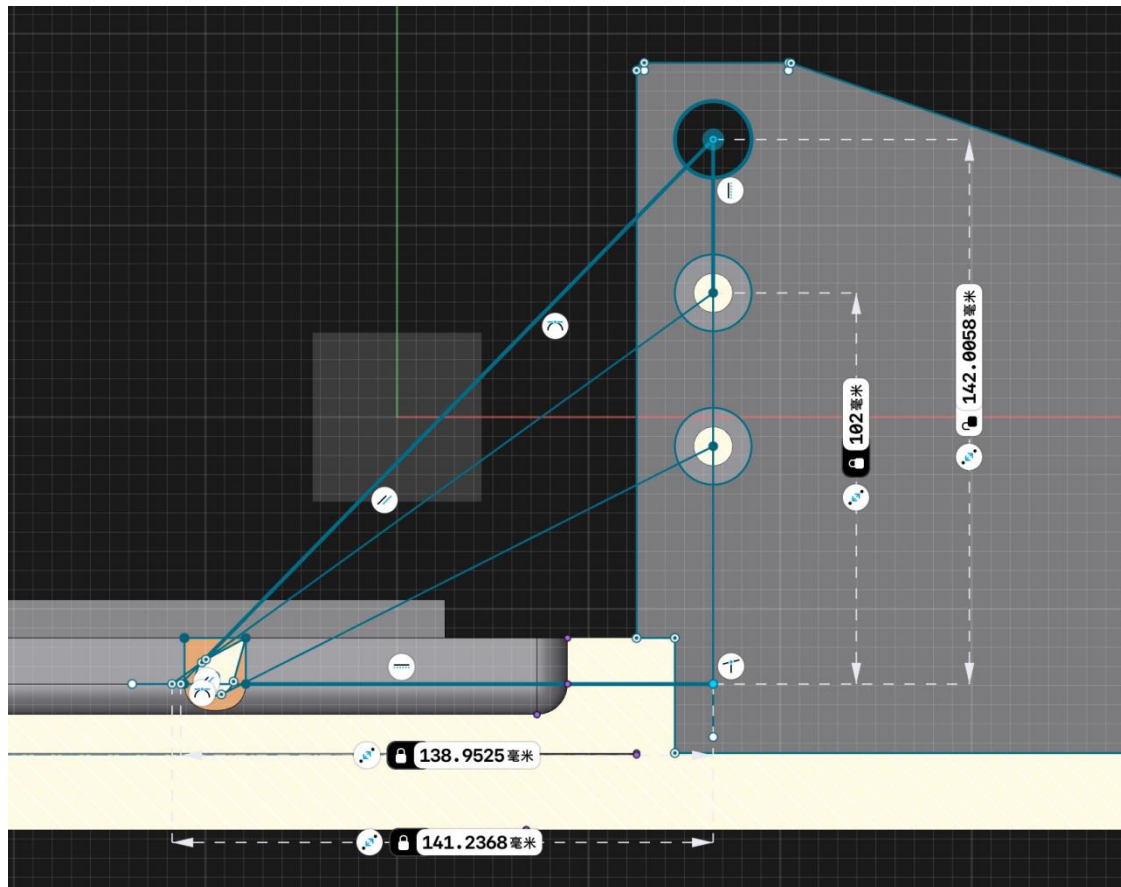

Figure5. Film deposition Angle and horizontal distance of tank

This part involves a special triangle formed by the shafts on the traction roller and deposition tank of an LB (Liquid-Based) film production machine. There are two scenarios to consider:

Low-perforation roller scenario: In this case, one leg of the right triangle is denoted as  $141.24\text{mm} + x$  in(mm), the other leg is  $102\text{mm}$ , and the corresponding angle is denoted as  $\alpha$ , the deposition angle.

High-perforation roller scenario: In this case, one leg of the right triangle is denoted as  $138.95\text{mm} + x$  in(mm), the other leg is  $142\text{mm}$ , and the corresponding angle is denoted as  $\beta$ , the deposition angle.

#### Calculations:

For both scenarios, the length of the hypotenuse  $c$  of the triangle can be calculated using the Pythagorean theorem:

$$c = \sqrt{(141.24\text{mm} + x)^2 + 102^2}$$

$$c = \sqrt{(138.95\text{mm} + x)^2 + 142^2}$$

For the low-perforation roller scenario, the deposition angle  $\alpha$  can be found using:

$$\alpha = \arctan\left(\frac{102}{141.24 + x}\right)$$

For the high-perforation roller scenario, the deposition angle  $\beta$  can be found using:

$$\beta = \arctan\left(\frac{142}{138.95 + x}\right)$$

These equations provide the relationship between the deposition angle and the horizontal distance of the tank for both low-perforation and high-perforation roller scenarios, considering  $x$  ranging from 0 to 225mm.

**Low-perforation roller scenario:**

For the maximum angle ( $\alpha_{\max}$ ):

$$\alpha_{\max} = \arctan\left(\frac{102}{141.24}\right) \approx 38.262^\circ$$

For the minimum angle ( $\alpha_{\min}$ ):

$$\alpha_{\min} = \arctan\left(\frac{102}{141.24 + 225}\right) \approx 24.154^\circ$$

**High-perforation roller scenario:**

For the maximum angle ( $\beta_{\max}$ ):

$$\beta_{\max} = \arctan\left(\frac{142}{138.95}\right) \approx 46.703^\circ$$

For the minimum angle ( $\beta_{\min}$ ):

$$\beta_{\min} = \arctan\left(\frac{142}{138.95 + 225}\right) \approx 27.031^\circ$$

These values represent the range of deposition angles for both scenarios with  $x$  ranging from 0 to 225 mm.

**2.2 Design Alternatives**

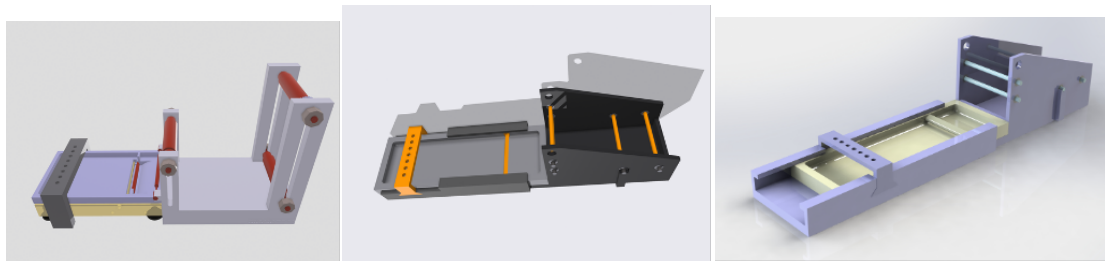

Figure6.Three design alternatives

The above three pictures, respectively, are the three successive design schemes, in which the transmission subsystem and the deposition tank subsystem as well as the connection method have been changed greatly. When facing the first version of the design structure (the leftmost part of the above picture), we found that the overly complicated Teflon results increased the difficulty of the processing and the useless design of the temperature deposition would only increase the height of the deposition tank, which reduces the stability of the deposition tank. We eliminated the temperature control system and simplified the Teflon tank design in the

second and third versions of the design, in addition to changes in the Teflon roller design. The new Teflon roller solves the problem of possible material spillage. Changes in the drive subsystem will be made according to quantitative calculations to determine the height of the drive subsystem of the various drums, to ensure that the angle of the deposited film between 10 degrees and 15 degrees, and increased damping at the unwinding drum, which can make the film is always in a taut state during the drive to improve the success of the film deposition rate and quality of the finished product. In addition, the connection method has changed from the initial use of screws, nuts, bolts and other overly complex rigid connections to a simple mortise and tenon structure, which greatly facilitates the assembly and cleaning of the accessories, so we finally got the design shown on the right.

### 2.3 Design Description & Justification

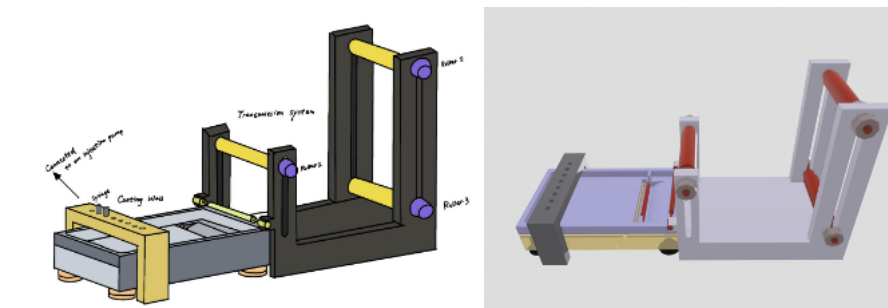

Figure7. First version design sketches and design models

This is the first version of the machine design for our project. After designing and modeling this version, we found that the overly complex tank structure of the deposition tanks (purple part of the above figure) was too difficult for the existing processing of Teflon materials, so we had to simplify the design of the deposition tanks and remove a temperature control system (yellow part of the above figure) in the first version of the design, because we found that our experimental environment was required to be in a relatively aseptic environment and the temperature was generally constant, so we removed the temperature control system which was not of much practical significance.

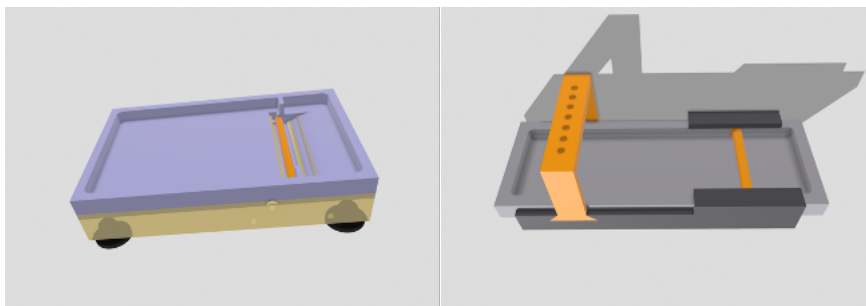

Figure8. Removal of the temperature control system associated with the water tank section

In addition, we also found that the original design of the deposition tank in the Teflon roll and page height has a certain height difference, and our material is floating on the liquid surface, so the material may cross the Teflon roll to the right side of the deposition tank body, so that

the other side of the hydrophilic film body to receive the material in advance of the adhesion, which will lead to we do not get a uniform and one-sided LB film, therefore, we have redesigned the Teflon roll, will be adapted from the style of the cylinder to the cross-sectional cross-section is a similar to the form of the water droplet, so that the material on the liquid surface will not cross the highest point of the cross-section, and will not be adhered to the other side of the film.

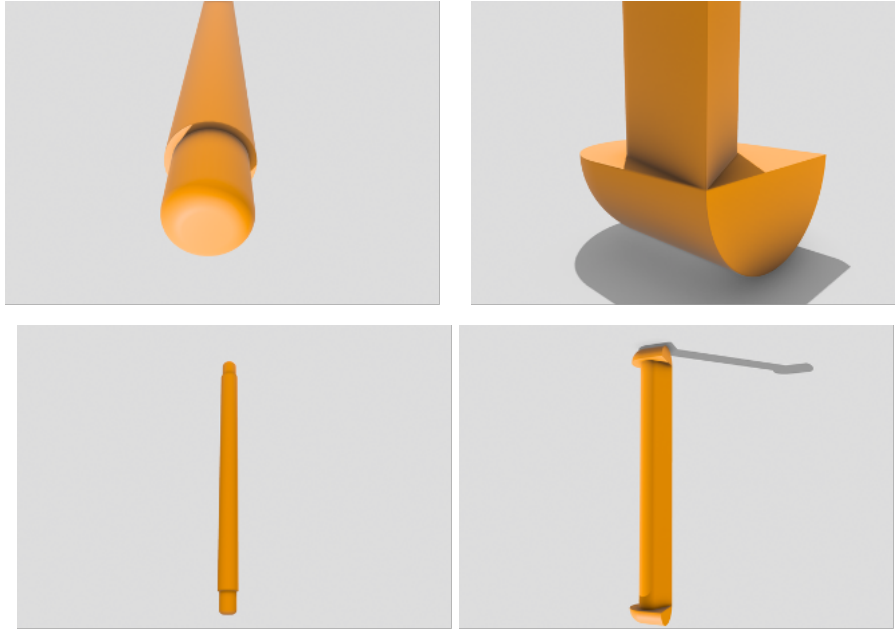

Figure9. Design Changes in Teflon Roller

After that again, we also changed the general design of the drive system so that we needed to use two stepper motors, one unwind roller and one rewind roller, and since we needed a deposition overlay angle of 10 to 15 degrees, we redesigned the drive to look like a trapezoid and to allow for side-to-side movement of the deposition tanks, and in order to secure the tanks to move side-to-side without up and down movement, we redesigned the base of the Teflon tanks as well. The base of the Teflon tank was also redesigned, and the clamps for fixing the tank were lengthened. However, we found that the connection between the drive system and the deposition tank may be unstable when moving the tank from side to side, and it is difficult to deposit the film at an angle of 10 degrees, so we redesigned the mortise-and-tenon rigid connection, and designed a distance-increasing module that can increase the distance between the deposition tank and the drive system.

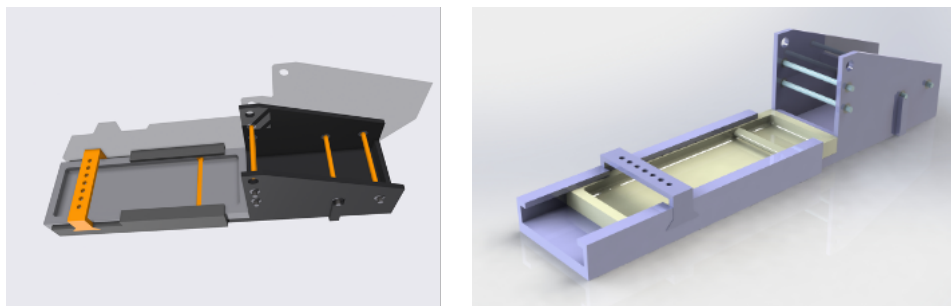

Figure10. redesign of the injection subsystem and the base of the fixed tank body

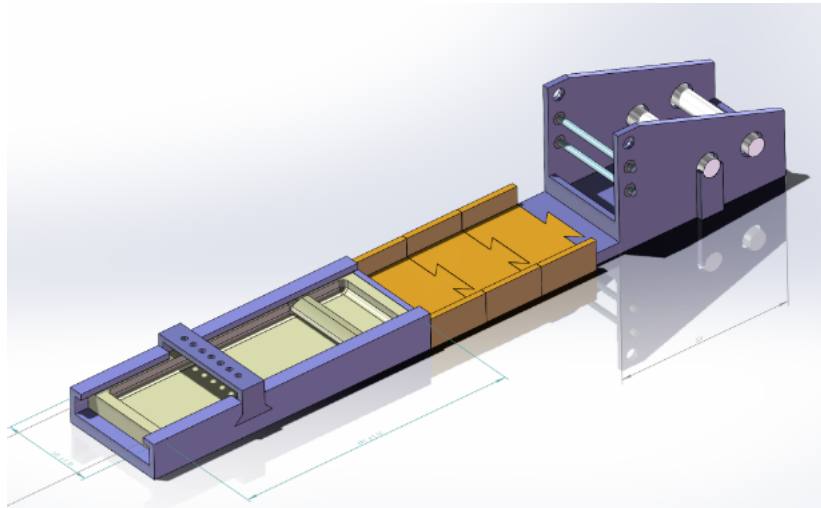

Figure 11. Final design of the main model

## 2.4 Subsystem Diagrams & Schematics

### 2.4.1 Transmission subsystem

The drivetrain hardware for the system includes several key components. It consists of a Teflon trough, which serves as the base for the film deposition process. The trough is designed to hold the liquid film material. Additionally, there are four rolls involved in the drivetrain system. Two of these rolls, used for roll-out and collection, are 3D printed and have a larger diameter of 30mm. The other two rolls, with a diameter of 10mm, are also part of the system. These rolls help guide and control the movement of the film material within the trough.

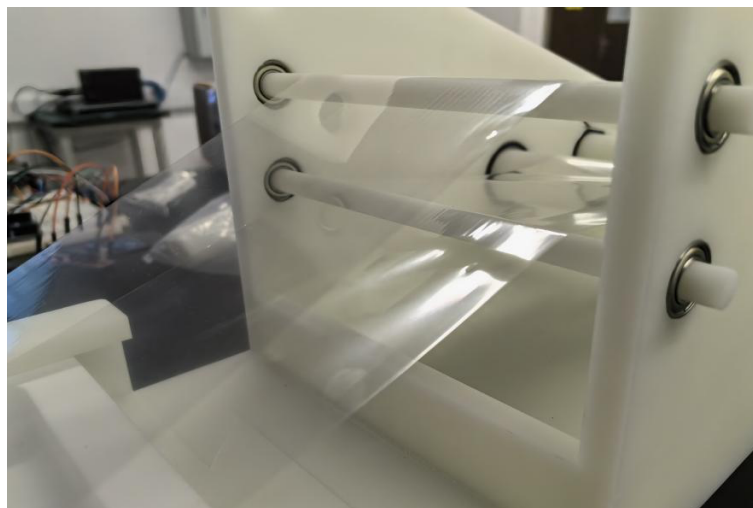

Figure 12. Physical photograph of two small guide rolls

The drivetrain is powered by a stepper motor, which provides the necessary rotational motion to drive the rolls. Belts are used to connect the stepper motor to the rolls, ensuring synchronized movement. The diameter of the Teflon roll is 10mm, which is standard for this type of application. Overall, the drivetrain hardware is designed to provide precise control over the movement of the film material, ensuring uniform deposition and high-quality results.

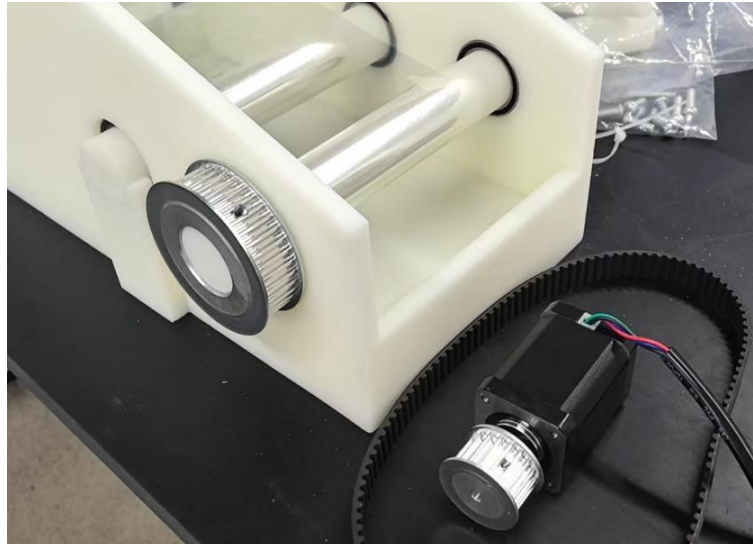

Figure13.Physical photos of components of the drivetrain

### 2.4.2 Material injection subsystem

The Injection Material Subsystem is composed of several components, including one motor, one large syringe, eight small syringes, and one bracket. The motor is responsible for controlling the movement of a plate positioned above the bracket, generating thrust to compress the large syringe. This action extrudes the material from the syringe, facilitating balanced feeding through a configuration where one syringe feeds in and eight syringes feed out.

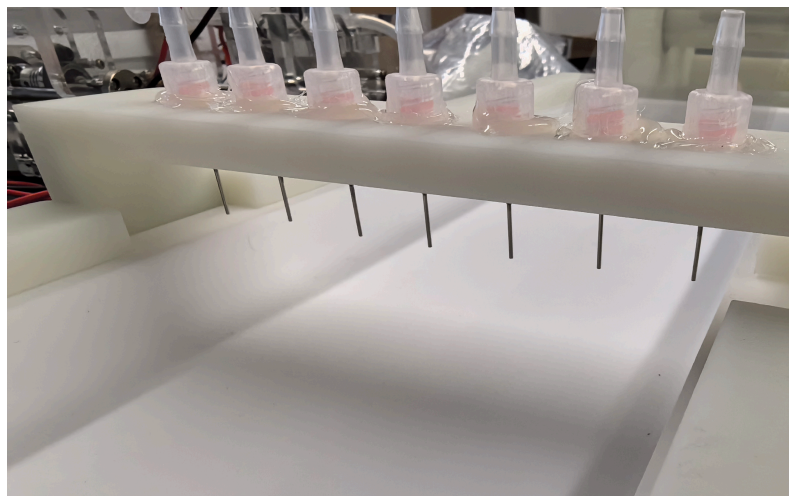

Figure14.Material addition needle

The material delivery system includes a syringe that contains the material to be deposited. This syringe is connected to the stepper motor, which drives the syringe plunger to dispense the material. The Arduino microcontroller sends precise commands to the stepper motor, controlling the rate and amount of material dispensed. This level of control allows for the material to be deposited evenly and at the desired thickness.

One of the key features of the subsystem is its compatibility with a wide range of materials, including liquids and pastes. The syringe and stepper motor are selected based on the

viscosity and volume of the material being deposited, ensuring that the system can handle various materials effectively.

To maintain precision and accuracy, the subsystem is equipped with sensors that monitor the amount of material dispensed in real time. This feedback allows for adjustments to be made to the dispensing rate as needed, ensuring that the deposition process remains consistent and uniform.

Safety features are also incorporated into the subsystem to prevent over-dispensing or leakage of the material, ensuring the safety of the equipment and the integrity of the deposited film.

This subsystem is crucial for the controlled delivery and distribution of materials within the system. The motor's precise control allows for accurate and consistent extrusion of material from the large syringe, which is then distributed through the smaller syringes. This setup enables the system to achieve uniform and controlled material deposition, ensuring the quality and integrity of the final product.

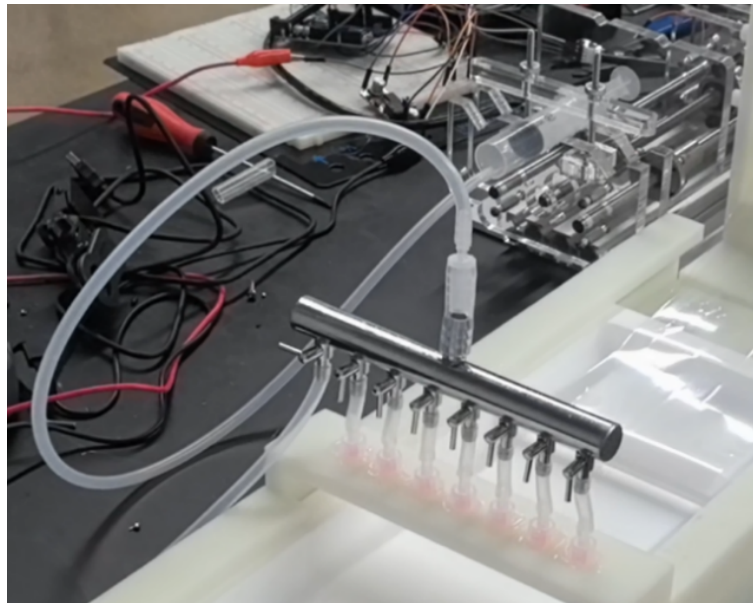

Figure15.Preliminary design of material addition subsystem

### 2.4.3 Diffusion trough subsystem

The deposition trough, fabricated from Teflon, is housed within a frame constructed of 3D printed parts. The Teflon trough's interior surface is intentionally smooth, facilitating easy cleaning and minimizing the risk of material residue accumulation.

The bracket's design features a mortise and tenon structure that securely connects it to the frame supporting the rolls. This structural arrangement ensures stability and precise alignment of the components. Additionally, the feeding table is rigidly affixed, further enhancing the overall stability of the system.

By limiting the movement of the Teflon trough to a one-way direction, the design promotes consistent and controlled material deposition, crucial for achieving the desired film thickness and uniformity. Overall, these design features contribute to the system's reliability and efficiency in thin film deposition processes.

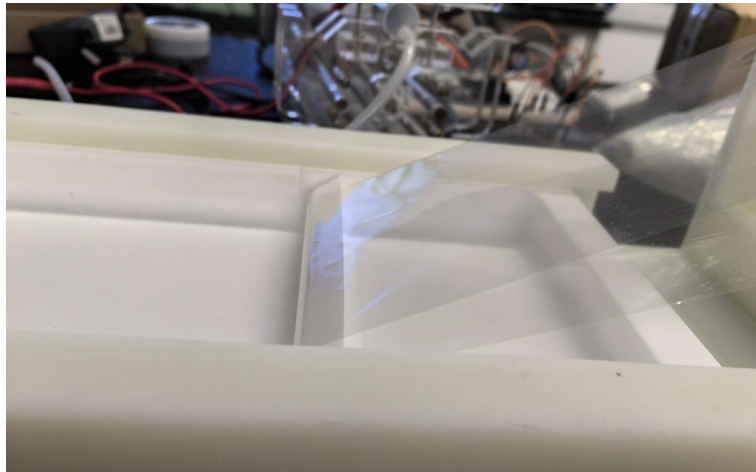

Figure16.Detail photo of Teflon roll

## 2.4.4 Power system

### 2.4.4.1 Image processing subsystem

In the film deposition process, the Brewster Angle Microscope (BAM) or a digital camera is employed to acquire real-time image data of the liquid surface. This data is then subjected to image processing algorithms, typically implemented in Python or other software, to analyze the thin film material's proportion. This proportion is calculated by dividing the material's area by the liquid surface area, providing a crucial metric for monitoring the deposition process.

The obtained proportion data is utilized for closed-loop control of the system using an Arduino microcontroller. For instance, if the calculated proportion falls below a predetermined threshold, such as 0.85, indicating an inadequate film deposition rate, the Arduino adjusts the speed of the stepper motor responsible for driving the film rotation. This adjustment aims to either decrease or increase the motor's speed, thus regulating the deposition rate and ensuring a more uniform film thickness.

This closed-loop control mechanism enables real-time adjustments to the deposition process, enhancing the system's efficiency and the quality of the deposited thin films.

Examples and renderings are shown below:

Figure17. Sample of film Figure18. Result of the sample

As shown in Figure 10, which depicts a sample membrane, and Figure 11, which illustrates the results, in our project, the gray area represents the effective membrane, while the area encircled by the green line represents interference or ineffective membrane in the experiment. Through our code, we can calculate the percentage of effective membrane occupying the entire liquid area in each membrane. For example, in Figure 11, the effective membrane occupies around 87% of the entire liquid, exceeding the set threshold of 85%. Therefore, we consider it a well-made membrane, and the experiment will proceed.



### 2.4.4.2 Electric control subsystem

The electric control subsystem in our project is a critical component responsible for controlling the motor's speed. It consists of Arduino and TB6600 drivers, which work together to regulate the stepper motor's rotation. The Arduino serves as the controller, executing programmed instructions to manage the motor's speed and direction. The TB6600 drivers amplify the control signals from the Arduino to provide the necessary power to drive the motor effectively. This subsystem's role is crucial, as it ensures precise control over the motor, allowing for accurate and reliable operation in our project.

## 3. Cost & schedule

### 3.1 Cost Analysis

Part	Model	Quantity	Unit price	cost (RMB)
Arduino circuit board		1	165	165
Step motor1	DFRobotTB6600	1	85	85
Step motor2	42BYGH40	1	125	125
Teflon parts	roller	1	640	640
	trough	1	2340	2340
3D print part	roller	4	120	480
	trough base	1	860	860
	frame	1	700	700
	syringe base	1	120	120
Bearing	40/30mm	8	4	32
Belt	85J	1	25	25
<b>Total</b>				<b>5572</b>

Figure19. Cost of all parts

### 3.2 Schedule

date	Monday	Tuesday	Wednesday	Thursday	Friday	Saturday	Sunday	EE Group member
3/11	Project Proposal due 11:59p	Mechanical system & Control system design draft			Cost evaluation	Model design determination		ME Group member
3/18	Animated demonstration	Control system drive demonstration	Customize Teflon parts					Whole Group
3/25	Project Proposal Regrade due	manufacturing	Submit design document	The design enables a fixed Teflon trough scheme				
4/1	Power system operation test, through the reducer drive roll to achieve low speed operation		Material addition subsystem test	Teamwork Evaluation I due 11:59p	Assembly test, friction part test			
4/8	Production result inspection	The first analysis and summary	Individual Progress Report due 11:59p	Problem feedback, hardware failure analysis, auxiliary parts procurement				
4/15	Integration of power system and transmission system.	Material addition system updates (with new shunt and barrel), avoids air leakage and is more accurate				Update of image acquisition system (fixed structure, output more distinguishable images)		
4/22	The second general test	design document Reflection	Liquid level maintenance test	Ultra-clean environment testing	Design Document Revision due - 11:59p	Analysis of ultra-clean laboratory test results and purchase of necessary components		
4/29	Second ultra-clean environment test	film preparation, complete the transmission system, power system, material addition system			Improve appearance and prepare demo			
5/6	Main Mock Demo Day	Comprehensive performance test preparation: solvent configuration, material configuration.		Circuit optimization, electronic component assembly	Mock Demo Final Report draft due 11:59p	Comprehensive testing using low-cost materials to check the material's suitability for film		
5/13	Conventional environment and prepare for display	Summarize and analyze.			Final Presentation due	Time buffer for possible problems during testing		

Figure20. Time schedule for different major members

## 4.Requirements & Verification

### 4.1 Completeness of Requirements & Appropriate Verification Procedures

#### 4.1.1 Power subsystem

##### 4.1.1.1 Electric control system

###### Requirements

**Winding Roller Assembly:** This assembly includes a roller integrated with a stepper motor. Its primary purpose is to control the winding of material onto the system. The stepper motor used has the following specifications:

**Step Angle:** 1.8 degrees.

**Phase Current:** 1.5A

**Static Torque:** 0.7 N\*m

**Power Supply for Stepper Motor (TB6600 Driver):** The TB6600 driver is powered by a dedicated power supply with the following specifications:

**Voltage:** 15V

**Current:** 1.5A

**Power Supply for Arduino:** The Arduino microcontroller is powered by a separate power supply with the following specifications:

**Voltage:** 5V

**Current:** 0.5A

**Control Code:** The stepper motor is controlled using the Arduino programming language, which is based on C/C++.

###### Verifications

**Winding Roller Assembly:** Use a digital protractor to measure the actual step angle of the stepper motor. Use a clamp meter to measure the phase current while the motor is in operation. Use a torque wrench to measure the static torque of the motor. Verify that the assembly can control the winding of material onto the system effectively by observing the material winding process under different operating conditions.

**Power Supply for Stepper Motor (TB6600 Driver):** Use a multimeter to measure the output voltage and current of the power supply. Ensure that the voltage is stable at 15V and the current is within the specified range of 1.5A. Use an oscilloscope to verify the stability of the voltage and current over time.

**Power Supply for Arduino:** Use a multimeter to measure the output voltage and current of the power supply for the Arduino. Ensure that the voltage is stable at 5V and the current does not exceed 0.5A. Use an oscilloscope to verify the stability of the voltage and current over time.

**Control Code:** Upload the control code to the Arduino and monitor its behavior using the Arduino IDE serial monitor. Verify that the code effectively controls the stepper motor according to the specified requirements by observing the motor's behavior and the winding of material onto the system.

**Overall System Verification:** Integrate the electric control subsystem into the larger system and test its interaction with other subsystems. Use the above-mentioned instruments to verify the operation of the electric control subsystem under various operating conditions. Conduct a series of tests to ensure that the subsystem operates as intended and contributes to the overall functionality of the deposition machine.

#### 4.1.1.2 Image processing subsystem

##### Requirements

**Real-time Image Acquisition:** The subsystem must be capable of acquiring high-resolution images of the liquid surface at a high frame rate to ensure accurate analysis of the thin film material.

**Image Processing Algorithms:** The subsystem must implement advanced image processing algorithms to accurately calculate the proportion of thin film material. These algorithms should be efficient and capable of handling large amounts of image data in real-time.

**Integration with Arduino:** The subsystem should be able to communicate effectively with the Arduino microcontroller to receive and process commands related to the deposition process, such as adjusting the speed of the stepper motor driving the film rotation.

**Closed-loop Control:** The subsystem should enable closed-loop control of the deposition process based on the calculated proportion of thin film material. This control mechanism should allow for real-time adjustments to the deposition rate to ensure uniform film thickness.

**Compatibility with BAM or Digital Camera:** The subsystem should be compatible with either a Brewster Angle Microscope (BAM) or a digital camera for image acquisition, providing flexibility in the choice of imaging hardware.

##### Verifications

**Real-time Image Acquisition:** Verification of the Image Processing Subsystem includes ensuring it can acquire high-resolution images of the liquid surface at a high frame rate. This involves testing the system to verify that the images acquired are of sufficient quality for accurate analysis of the thin film material.

**Image Processing Algorithms:** Verification of the Image Processing Subsystem involves implementing and testing advanced image processing algorithms to accurately calculate the proportion of thin film material. Additionally, it includes verifying that these algorithms are efficient and capable of handling large amounts of image data in real-time. **Integration with Arduino:** Verification of the Image Processing Subsystem includes ensuring effective communication between the subsystem and the Arduino microcontroller. This involves testing the subsystem's ability to receive and process commands from the Arduino related to the deposition process, such as adjusting the speed of the stepper motor.

**Closed-loop Control:** Verification of the Image Processing Subsystem includes verifying that it enables closed-loop control of the deposition process based on the calculated proportion of thin film material. Additionally, it involves testing the control

mechanism to ensure it can make real-time adjustments to the deposition rate to achieve uniform film thickness.

**Compatibility with BAM or Digital Camera:** Verification of the Image Processing Subsystem includes ensuring compatibility with both Brewster Angle Microscopes (BAM) and digital cameras for image acquisition. Additionally, it involves testing the subsystem with both types of imaging hardware to ensure flexibility and compatibility.

#### 4.1.2 Transmission subsystem

##### Requirements

**Frame:** The frame of the system is a key structural component, designed in a trapezoidal shape and manufactured using 3D printing technology. It is constructed from photosensitive resin material, providing durability and stability to the entire transmission subsystem. The frame serves as the foundational support, ensuring proper alignment and functionality of all system components.

**Feeding Roller Assembly:** The feeding roller assembly, a critical component of the system, comprises a roller integrated with an adjustable damping mechanism. This mechanism plays a pivotal role in regulating the material feeding process onto the system. By controlling the damping mechanism, operators can finely adjust the material feed rate, ensuring optimal deposition conditions for the thin film. This precise control is essential for achieving uniform film thickness and high-quality deposition results.

##### Verifications

**Frame:** Verification of the frame includes ensuring its trapezoidal shape matches design specifications using a measuring tape or ruler, verifying its material through material analysis tests, or manufacturing documentation, conducting stability tests with controlled forces to assess its load-bearing capacity, and checking alignment with a level to ensure proper functionality of all system components.

**Feeding Roller Assembly:** Verification of the feeding roller assembly involves verifying the integration of the damping mechanism with the roller, conducting feeding tests to observe and measure the material feed rate under various damping settings, ensuring the adjustment mechanism of the damping mechanism functions smoothly and accurately, and measuring the film thickness at different points on the substrate to verify the uniformity achieved by the feeding roller assembly.

#### 4.1.3 Deposition tank subsystem

**Deposition Tank:** The deposition tank is a specialized container constructed from Teflon material, meticulously designed to store and dispense the deposition material essential for the manufacturing process. This tank is engineered to provide a suitable environment for the deposition material, ensuring its integrity and preventing contamination. Its design includes features that facilitate easy filling, dispensing, and cleaning, ensuring efficient and reliable operation throughout the deposition process.

**Special Shaft:** This specialized Teflon shaft plays a crucial role in the deposition process, ensuring the uniform distribution of deposition material onto the substrate or film surface. Its design and material properties are tailored to facilitate smooth and consistent material flow, preventing uneven deposition or buildup. The shaft's precise engineering enables it to

efficiently distribute the material across the substrate, contributing to the overall quality and uniformity of the deposited film.

**Sliding Platform:** The sliding platform serves as a movable base for the deposition tank within the system. It facilitates easy access to the tank for maintenance and material replenishment. Additionally, it connects to the base of the transmission subsystem, ensuring proper alignment and integration between the two subsystems.

Verifications

**Deposition Tank:** Verification of the deposition tank includes ensuring it is constructed from Teflon material, verifying its design for storing and dispensing deposition material, checking that the design allows for easy filling, dispensing, and cleaning, and testing its operation to ensure efficient and reliable performance throughout the deposition process.

**Special Shaft:** Verification of the specialized Teflon shaft involves ensuring it is installed correctly, conducting tests to verify its ability to facilitate uniform distribution of deposition material onto the substrate or film surface, checking for smooth and consistent material flow along the shaft, and measuring the distribution of material across the substrate to confirm the shaft's effectiveness in achieving uniformity.

**Sliding Platform:** Verification of the sliding platform includes verifying its functionality as a movable base for the deposition tank, ensuring it allows easy access to the tank for maintenance and material replenishment, checking the alignment and integration between the platform and the base of the transmission subsystem, and testing its stability and movement to ensure proper functionality within the system.

#### 4.1.4 Injection material subsystem

Requirements

**Bracket for Injector Installation:** The bracket is a mounting structure designed to securely hold and position the injectors within the system. It is capable of simultaneously accommodating up to eight injectors, providing versatility and scalability to the injection process.

**Injectors:** These specialized devices are responsible for precisely dispensing the injection material onto the designated surface or substrate. Their configuration, including nozzle design, flow rate, and control mechanisms, will be tailored to the specific requirements of the manufacturing process.

**Injection Pump:** The injection pump is responsible for accurately delivering the injection material to the injectors, ensuring a controlled and consistent flow during operation. Its design may incorporate features such as reservoirs, feed mechanisms, and sensors to monitor material levels and flow rates effectively.

Verifications

**Bracket for Injector Installation:** Verification of the bracket for injector installation involves ensuring that it securely holds and positions up to eight injectors within the system. This includes checking the bracket's mounting structure for stability and compatibility with the injectors. Additionally, the verification process should ensure that the bracket allows for easy installation and removal of injectors as needed.

**Injectors:** Verification of the injectors includes conducting tests to verify that they precisely dispense the injection material onto the designated surface or substrate. This involves checking the configuration of the injectors, including the design of the nozzles, flow rate, and control mechanisms, to ensure they meet the specific requirements of the manufacturing process.

**Injection Pump:** Verification of the injection pump involves several steps. Firstly, the pump should be tested to ensure it accurately delivers the injection material to the injectors. Secondly, it should be verified that the pump maintains a controlled and consistent flow during operation. Additionally, features such as reservoirs, feed mechanisms, and sensors should be checked to ensure effective monitoring of material levels and flow rates. Lastly, the pump's design should facilitate easy maintenance and adjustment of flow rates.

#### **4.1.5 Tolerance Analysis**

The main load that affects the work of the product comes from the tension between the output roll and the collection roll. We need to make sure the film stays tight while having enough power to drive the overall motion. We plan to put the output of the motor through the reduction gear set to achieve a low speed.

Gear ratio: 1:100.

film moving speed: 5-20mm/h

Friction on the resistance roll: 2-5N

Single operation duration: 5-20hours

#### **4.2 Quantitative Results**

##### **Test plan**

Verification of the Continuous Roll-To-Roll LB Film Deposition Machine involves ensuring that the system meets its design specifications and performs as intended. This process includes several steps to validate the functionality and performance of the machine.

Firstly, the individual subsystems, such as the Power Supply, Winding Roller Assembly, Injection Material Subsystem, and Image Processing Subsystem, are tested independently to verify their functionality. This includes testing the stepper motors, sensors, and control algorithms to ensure they operate as expected.

Next, the integration of these subsystems is tested to ensure they work together seamlessly. This involves running the machine through a series of tests to verify that the material is deposited evenly and at the desired thickness, and that the substrate moves smoothly through the deposition process.

Once the integration testing is complete, the machine undergoes performance testing to verify its overall performance. This includes testing the machine under different operating conditions to ensure it can handle varying speeds, material viscosities, and substrate sizes.

Additionally, the machine is tested for reliability and durability to ensure it can operate continuously for extended periods without failure. This involves running the machine for an extended period under normal operating conditions to identify any potential issues that may arise over time.

Overall, the verification process ensures that the Continuous Roll-To-Roll LB Film Deposition Machine meets its design specifications and performs reliably and consistently in a production environment. Any issues identified during the verification process are addressed and resolved to ensure the machine meets the highest standards of quality and performance.

### 4.3 Result

Test instructions:

film: Hydrophilic film

Material: colored polar pigment

Solvent: 0.1% thickener

Diffusion range: 5.5-21.6 cm

Diffusion rate: 3.5s/cm (it takes 35 seconds to spread to 10cm, and the speed is decreasing)

Through testing, the use of hydrophilic film can significantly improve the ability of the material to adhere to the film surface. This is because the movement of the hydrophilic film drives the flow of the solvent, pulling the material on the surface of the solvent to the surface of the film through tension.

The test results show that the polarity material is well adapted to film, and the main functions of the device can be realized. The next test is to experiment with nanomaterials (invisible to the naked eye, high cost).

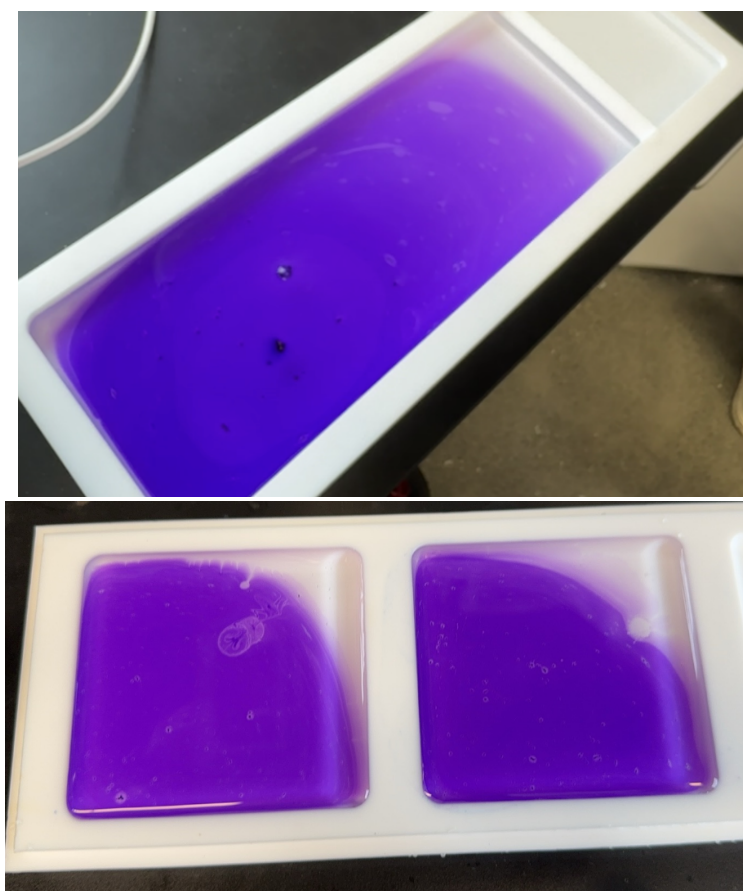

Figure21. Material diffusion test



Figure22. Material and film fit test

## 5. Conclusion

### 5.1 Accomplishments

This project has successfully developed a Continuous Roll-To-Roll Thin Film Deposition Machine based on Langmuir-Blodgett (LB) coating technology, achieving several significant successes in functionality and performance.

**Precise Control and Uniformity:** The machine demonstrates exceptional control over the arrangement and orientation of nanomaterials, resulting in highly ordered and uniform thin films. This level of control is paramount for tailoring coating properties for diverse applications, such as electronics and photonics.

**Scalability:** Through the utilization of a Roll-To-Roll dual-roller structure, our machine has effectively overcome the scalability limitations inherent in traditional LB coating techniques. It can efficiently produce large-area coatings, rendering it suitable for industrial-scale manufacturing.

**Enhanced Production Efficiency:** The innovative design of our machine has markedly improved production efficiency compared to traditional LB coating methods. The incorporation of high-quality Teflon trough material and effective self-spreading techniques has ensured consistent film properties and enhanced coating quality.

**Quality Control:** Our machine has addressed the quality control challenges faced by traditional LB coating processes, such as uneven coating thickness and the formation of bubbles. The implementation of moving water and precise temperature control has resulted in more uniform coatings with fewer defects.

**Practical Application:** The successful development of our machine has opened new avenues for the commercialization and practical application of LB films. Its capability to produce nanofilms with enhanced functionalities and performance will advance the fields of material science and nanotechnology.

#### **Functionality:**

The final functionality of our Continuous Roll-To-Roll Thin Film Deposition Machine includes:



1. Efficient material self-spreading techniques to ensure uniform coating distribution.
2. The utilization of high-quality Teflon trough material for compatibility with a wide range of solvents and chemicals, preventing material adherence to trough walls, and facilitating smooth substrate movement.
3. Stretching and drawing of the polymer film substrate to align polymer chains, increase crystallinity, enhance mechanical and barrier properties, and enable the deposition of thinner films.
4. Precise control over the arrangement and orientation of nanomaterials for tailored coating properties.
5. Scalability for large-area manufacturing, making it suitable for industrial applications.
6. Improved production efficiency and quality control compared to traditional LB coating techniques.

Overall, this project has achieved its objective of developing an innovative Continuous Roll-To-Roll Thin Film Deposition Machine based on LB coating technology, with significant advancements in production efficiency, quality control, and scalability.

## **5.2 Uncertainties**

One of the next phases of testing will focus on the Image Processing Subsystem, which is scheduled for the upcoming week. This subsystem plays a critical role in analyzing the deposited film for continuity and uniformity. Testing will involve capturing images of the deposited film and processing them to extract relevant information. The goal is to verify that the Image Processing Subsystem can accurately assess the quality of the film deposition and provide feedback for process control.

The diffusion rate of polar material on solvent surface is not constant. The diffusion speed shows a decreasing trend, so when adjusting the diffusion distance, it may be necessary to re-adjust the moving speed of the film. This ensures a uniform distribution of the material on the surface of the film.

When the device is operating, the motion of the film may cause a disturbance in the liquid surface of the Teflon trough, resulting in solvent overflow. It is necessary to control the smooth operation of the film and keep the liquid level not more than the excessive surface of the trough when adding solvent at the initial stage (add a little less solvent).

## **5.3 Future Work / Alternatives**

### **Enhancing Production Efficiency:**

**Optimization of Coating Process Parameters:** Investigate the impact of different coating parameters, such as coating speed, pressure, and temperature, on coating properties to find the optimal parameter combination.

**Improvement of Material Handling System:** Design a more efficient material supply and recovery system to reduce material waste and improve coating consistency.

**Implementation of Automation Technology:** Explore the use of machine vision and automatic control systems to achieve automated coating processes, enhancing production efficiency and consistency.

### **Strengthening Quality Control:**

Real-time Monitoring System: Develop a real-time monitoring system capable of tracking coating thickness and uniformity, and automatically adjusting coating parameters to ensure consistency.

Application of Imaging Techniques: Explore the use of high-resolution imaging techniques, such as laser scanning microscopy or infrared imaging, for defect detection and identification, improving quality control.

### **Enhancing Scalability:**

Machine Design Improvements: Redesign the machine structure to accommodate larger substrate sizes while ensuring coating quality and consistency.

Optimization of Production Processes: Optimize production processes, including material supply chain management and workflow planning, to increase throughput and efficiency of production lines.

### **Exploration of Alternative Coating Technologies:**

Application of Spray Coating Technology: Investigate the application of spray coating technology in thin film deposition, evaluating its impact on coating performance and quality.

Exploration of Spin Coating Technology: Explore the potential advantages of spin coating technology, such as higher coating speeds and more uniform coating thickness distribution.

## **5.4 Ethical Considerations**

### **5.4.1 Ethics**

Inspired by the ethic of community [1], we summarize the following ethical concerns.

that apply to this project:

1. Evaluate the societal impact of our project: It is imperative to assess how our project affects society comprehensively, encompassing social, economic, and environmental dimensions. This entails adopting a holistic perspective to consider not only immediate advantages but also potential long-term ramifications.
2. Adhere to principles of equity and impartiality: We must ensure that our project is equitable and impartial, devoid of any discrimination based on attributes such as race, gender, religion, or nationality. This necessitates acknowledging and addressing potential biases.
3. Demonstrate honesty and transparency: Upholding honesty and transparency in our professional conduct, including communication with team members, teaching assistants, instructors, and the public, is essential. This involves candidly addressing potential risks and uncertainties and disclosing any conflicts of interest.

### **5.4.2 Safety**

Drawing inspiration from lab safety research [2], we outline the following safety considerations relevant to this project:

1. Lab safety: The design and testing of our LED display system involves working with various tools, equipment, and materials that can pose hazards to our members. This includes

ensuring that all of us are trained in proper safety procedures, that appropriate safety equipment is available, and that all testing and assembly is performed in a designated and controlled laboratory environment.

2. Electrical safety: The power system involved in our project could pose risks of electrocution or electrical fires if proper safety measures are not taken. This includes ensuring that all wiring is properly insulated and grounded, that circuits are appropriately sized and protected, and that appropriate safety equipment is available for handling and testing electrical components.

3. Mechanical safety: The rotating motor involved in our project could pose risks of injury or damage to equipment if not properly installed or operated. This includes ensuring that the motor is securely mounted and that all moving parts are properly guarded to prevent contact with users or other objects.

## 6. Reference

- [1] Furman, G. C. (2004). The ethic of community. *Journal of educational administration*, 42(2), 215-235.
- [2] Ménard, A. D., & Trant, J. F. (2020). A review and critique of academic lab safety research. *Nature chemistry*, 12(1), 17-25.
- [3] Hassan, M., Ghaffar, A., Lou, G., Miao, Z., Peng, Z., & Celebi, K\*. (2024). Enhanced Transport Kinetics of Electrochromic Devices by W18O49 NW/Ti3C2Tx Composite Films. *Advanced Functional Materials*. Just accepted.
- [4] Ghaffar, A., Hassan, M., Penkov, O. V., Yavuz, C. T., & Celebi, K\*. (2023). Tunable Molecular Sieving by Hierarchically Assembled Porous Organic Cage Membranes with Solvent-Responsive Switchable Pores. *Environmental Science and Technology*, 6(4), 1801570. <https://doi.org/10.1021/acs.est.3c05883>
- [5] Li, P., Han, L., Kim, D., & Celebi, K\*. (2024). A fast synthetic strategy for quick preparation and optimization of platelike MFI crystals. *Microporous Mesoporous Materials*, 365, 112965. <https://doi.org/10.1016/j.micromeso.2023.112905>
- [6] Celebi, K., Buchheim, J., Wyss, R. M., Droudian, A., Gasser, P., Shorubalko, I., Kye, J., Lee, C., & Park, H. G. (2014). Ultimate Permeation across Atomically Thin Porous Graphene. *Science*, 344(6181), 289-29