

ECE 445  
SENIOR DESIGN LABORATORY  
FINAL REPORT

---

TOUCH CONTROLLED PROGRAMMABLE  
DC POWER SUPPLY CIRCUIT

---

**Team #20:**

Weisong Shi (weisong4)  
Chaoli Xia (chaolix2)  
Yiyi Wang (yiyi4)  
Sichen Wang (sichenw2)

**Sponsor:**

Aili Wang

May 2024

## Abstract

This report outlines the development and implementation of a touch-controlled programmable DC power supply. The project aimed to address the challenges posed by conventional power supplies by creating a system that is user-friendly, adaptable, and efficient. The design comprises four main modules: AC-DC conversion, variable voltage regulation, touch control, and protection circuits. The AC-DC converter ensures stable transformation from 220V AC to low voltage DC, while the variable voltage regulator provides adjustable output to meet diverse needs. The touch control module enhances user interaction, enabling intuitive voltage adjustments. The protection subsystem ensures system safety and reliability. The final prototype successfully achieved precise voltage control with high sensitivity and stability, incorporating self-protection features and clear visualization of output voltage. Future work will focus on integrating additional efficiency functions and exploring alternative power supply designs to reduce system power loss.

**Keywords:** AC-DC Power Supply, Variable Voltage Regulation, PWM Control, Touch control, Voltage adjustment

# Contents

- 1 Introduction** **1**
  - 1.1 Problem . . . . . 1
  - 1.2 Solution . . . . . 1
  - 1.3 Block Diagram . . . . . 1
  
- 2 Design** **3**
  - 2.1 AC-DC Conversion Subsystem . . . . . 3
    - 2.1.1 Subsystem Overview . . . . . 3
    - 2.1.2 Component Selection . . . . . 4
    - 2.1.3 Simulation . . . . . 5
  - 2.2 Variable Regulated Power Supply Subsystem . . . . . 6
    - 2.2.1 Subsystem Overview . . . . . 6
    - 2.2.2 Component Selection . . . . . 8
    - 2.2.3 Simulation . . . . . 11
  - 2.3 Touch Control Subsystem . . . . . 12
    - 2.3.1 Design procedure . . . . . 12
    - 2.3.2 Design details . . . . . 14
  - 2.4 Protection Subsystem . . . . . 18
    - 2.4.1 Design Procedure . . . . . 18
    - 2.4.2 Design Details . . . . . 18
  
- 3 Design Verification** **20**
  - 3.1 AC-DC Conversion Subsystem . . . . . 20
  - 3.2 Variable Regulated Power Supply Subsystem . . . . . 20
  - 3.3 Touch Control Circuit . . . . . 21
  - 3.4 Protection . . . . . 21
  
- 4 Costs** **22**
  - 4.1 Cost Analysis . . . . . 22
  - 4.2 Schedule . . . . . 22
  
- 5 Conclusion** **23**
  - 5.1 Accomplishments . . . . . 23
  - 5.2 Uncertainties and Future Work . . . . . 23
  - 5.3 Ethical Considerations . . . . . 23
  
- 6 References** **25**
  
- A Schedule** **26**
  
- B PCB Layout Design** **28**

# 1 Introduction

## 1.1 Problem

The modern operation of electronic devices heavily relies on DC power sources at various voltage levels. This variability underscores the importance of voltage adaptation mechanisms for optimal functionality across consumer electronics. Take ubiquitous gadgets like cell phones, watches, and Kindles, which consistently require a standardized 5V supply. Mobile power, typically battery-operated, must meet diverse energy source demands, from 1.2V Nickel Metal Hydride to multiple Li-ion cells. Laptops, with nuanced power dynamics, often need 12V adapters for effective motherboard power[2].

Our project aims to develop a user-friendly, touch-sensitive, and programmable DC power supply system, bypassing constraints of disparate units. By integrating intuitive controls and touch functionality, we enhance accessibility and ease of operation, allowing users to adjust settings effortlessly. Programmability enables customization, fostering versatility in diverse applications. Ultimately, we aim to provide a flexible solution, addressing challenges posed by conventional power supplies and promoting innovation in various fields.

## 1.2 Solution

To achieve this functionality, we have decided to divide the project into four modules, namely the AC-DC Converter, Variable Voltage Regulator, Touch Control Circuit, and Short Circuit Protection module.

The first part is to realize the transformation from AC to DC. AC-DC converters have been developed to a matured level with improved power quality in terms of power-factor correction, reduced total harmonic distortion at input AC mains, and regulated DC output in buck, boost, buck-boost, multilevel, and multipulse modes with unidirectional and bidirectional power flow[1]. Next, we will design a component to regulate different voltage levels. This component serves as a reliable source of DC output, capable of meeting various voltage requirements with stability and adjustability. We also need to deal with the touch control unit. We need to design a component that provides touch-sensitive controls for user interaction. It includes touch sensors (touch plate), digital integrated circuits, and other circuits to generate control signals for the variable voltage control circuits. We plan to apply The CTSs, which include the touch sensor, analog front-end (AFE) integrated circuit (IC), and micro-controller unit[3]. The short circuit protection part plays a critical role in safeguarding the circuit and the connected devices by detecting and mitigating short circuits. It incorporates specialized current sensors and overcurrent protection components to monitor the flow of electrical current within the circuit.

## 1.3 Block Diagram

As shown below, our project integrates four subsystems to fulfill specific requirements. The AC-DC Converter ensures efficient conversion of AC to DC, providing a stable input for subsequent stages. The Variable Regulated Power Supply Circuit enables precise control over output voltage levels, meeting the requirements of charging voltage of diverse electronic

applications. The Touch control circuit creates convenient user interaction, allowing users to easily adjust parameters with a simple touch interface. Additionally, the Short Circuit Protection Circuit enhances safety and reliability by swiftly detecting and mitigating short circuit events. This comprehensive design approach helps to ensure that the final product meets the high-level requirements.

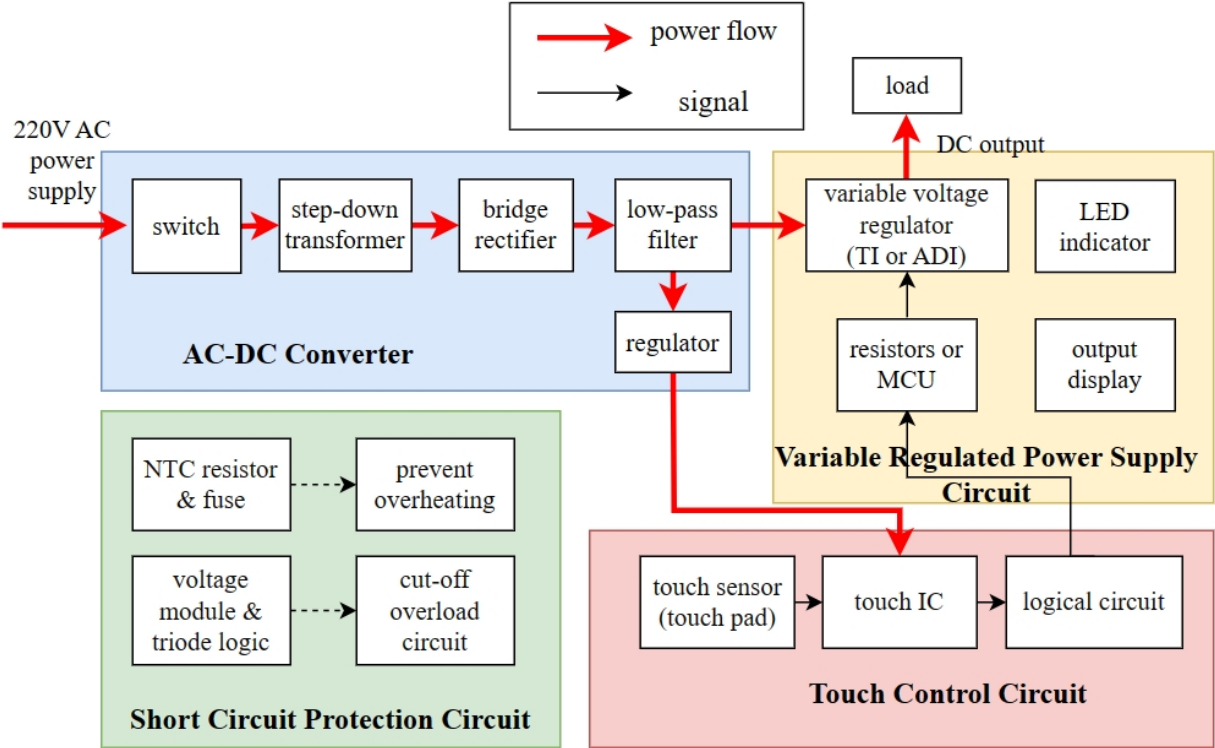

Figure 1: block diagram

# 2 Design

## 2.1 AC-DC Conversion Subsystem

### 2.1.1 Subsystem Overview

The AC-DC Conversion Subsystem is intended to efficiently convert AC to DC to power the circuit. It includes a switch, a step-down transformer, a bridge rectifier, and a low-pass filter circuit to ensure efficient and reliable power conversion. The purpose of this subsystem is to flexibly connect external power sources and convert them to provide a stable direct current power supply for the entire system.

- **Step-down Transformer:** Transfers the 220 VAC mains voltage to a lower level of AC voltage.
- **Rectifier:** Used to convert the input AC signal  $V_s$  to a one-sided signal.
- **Filter:** The output of the rectifier is passed through a filter block to reduce ripple in the signal.
- **Regulator:** Used to further reduce the ripple in the voltage and to give a stable DC output voltage. In this subsystem, there is a regulator to provide a stable 5V power supply for chips in the touch control subsystem. The adjustable regulator is applied in the variable-regulated power subsystem.
- **Switch:** A switch is placed on the power cord to ensure the bottom line of safety and for the convenience of controlling the power supply of the entire system.

The technology we use in this project to complete AC-DC conversion is the same as we learned in the course ECE 343. Here’s the diagram indicating the principle.

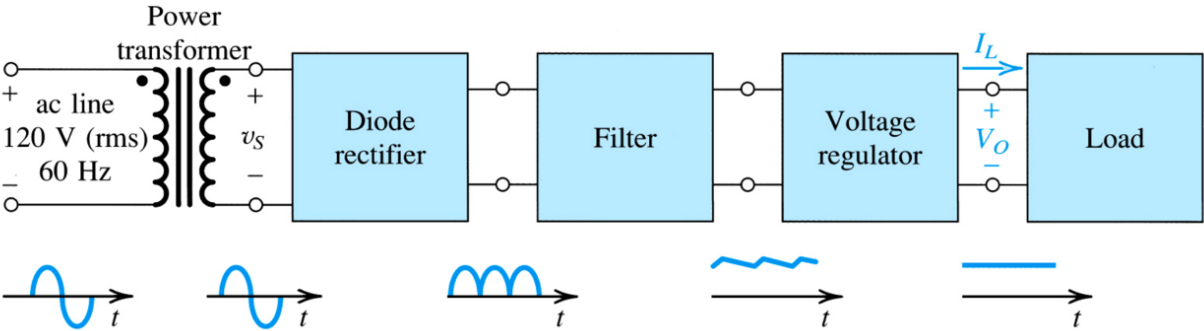

Figure 2: AC-DC Power Supply

And the circuit diagram of the subsystem:

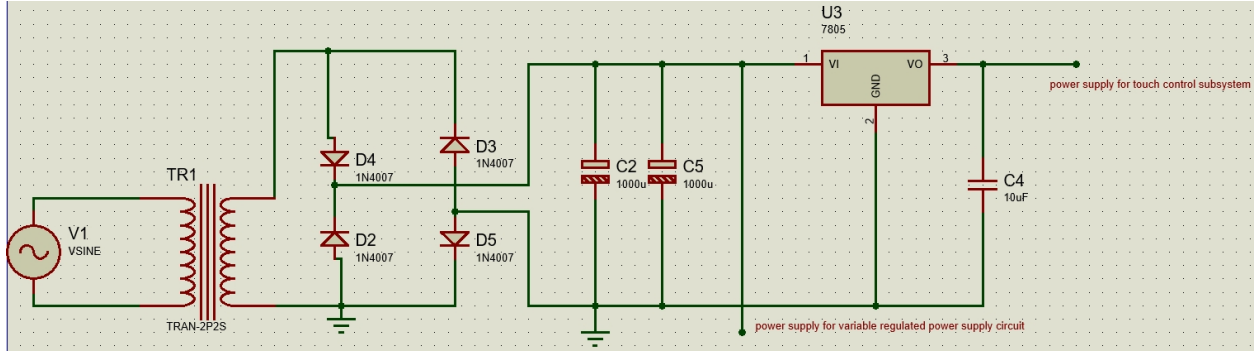

Figure 3: AC-DC Circuit Diagram

### 2.1.2 Component Selection

Considering the maximum output voltage of 20 volts from the Variable Regulated Power Supply Circuit, the output voltage of the AC-DC Conversion Subsystem should be slightly higher than 20 volts. According to the formulas below[4], we choose the transformer that can convert 220 volts AC into 18 volts AC. Then after rectification and filtering, the output will be slightly lower than  $18 \cdot \sqrt{2}$  volts, which ensures compatibility between subsystems and optimizes system performance.

According to the power requirement, the output current should be able to reach 1A. Because the total voltage drop is  $18 \cdot \sqrt{2}$ , about 25 volts, the power of the transformer should be at least 30W. Unfortunately, we cannot find a transformer on the PCB that fulfills the requirement, so the transformer will be placed separately from the PCB.

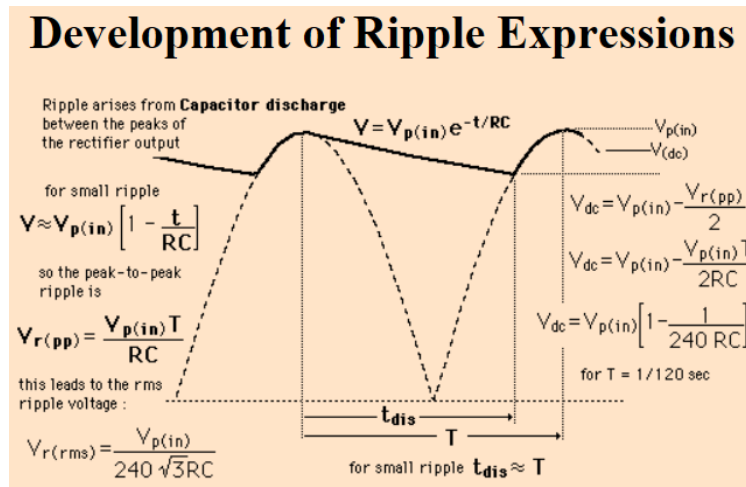

Figure 4: Formulas for Full-wave Rectifier

For the rectifier, we choose to use the full bridge rectifier to convert the AC voltage into DC voltage. It consists of four general-purpose rectifier diodes. The circuit design is shown below.

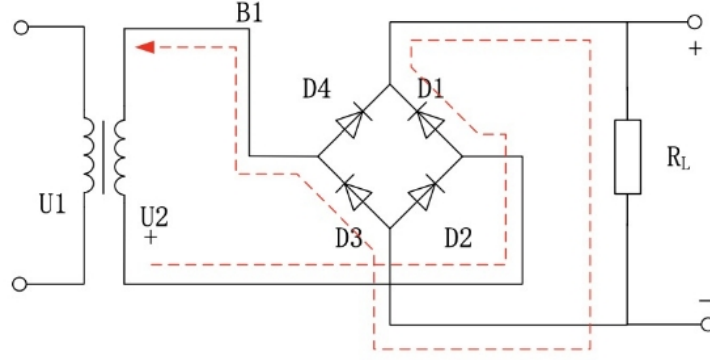

Figure 5: Circuit Design for Full Bridge Rectifier

The model we chose is D1N4007, because of its wide work range. According to the datasheet[5], the peak repetitive reverse voltage is 1000V and the average rectified forward current is 1A.

For the low-pass filter, we choose capacitors to reduce the ripple voltage. To select the appropriate capacitance, we also need to refer to the formulas above. The ripple voltage across the capacitor is:

$$V_{\text{ripple},C} = \frac{I_L}{f \cdot C} \quad (1)$$

Where  $I_L$  is the *DC* component of the load current and  $f$  is the frequency of the filter output. The capacitance of the filter capacitor can be calculated using the formula. In our design, the  $f = 50\text{Hz}$ , and we design that our current can be over 1 A when the output voltage is 5 volts, so  $2000\mu\text{F}$  should be enough.

For the regulator to supply power for the chips in the Touch Control Subsystem, we plan to use an LDO. For the chip RH6015, a voltage supply of about 5 volts is enough. We chose to use CJ7805, which is a 3-pin device. According to its datasheet[6], its maximum input voltage is 35V and its maximum output current is 1.5A, which is satisfied in the design.

### 2.1.3 Simulation

For simulation purposes, I've configured the AC voltage source to produce a sine wave with a peak voltage of 310 volts and a frequency of 50 Hz. This ensures it meets the specified standards and facilitates accurate testing and evaluation of the AC-DC converter subsystem.

In Proteus, the turn ratio of the transformer can be set by adjusting the inductance of the coupled inductors. The formulas are shown below (to get a secondary voltage of 18V)[7]:

$$\text{TurnsRatio} = \frac{V_{\text{primary}}}{V_{\text{secondary}}} = \frac{V_{\text{in}}}{V_{\text{sec}}} = 220/18 = 12.22 \quad (2)$$

$$\text{TurnsRatio}^2 = \left( \frac{V_{\text{in}}}{V_{\text{sec}}} \right)^2 = \frac{\text{PrimaryInductance}}{\text{SecondaryInductance}} = 12.22^2 = 149.33 \quad (3)$$

Assume that the primary inductance is  $400 \mu\text{H}$ , then the secondary inductance is:



$$\frac{400\mu H}{149.33} = 2.68\mu H \quad (4)$$

The power supply for the Variable Regulated Power Supply Subsystem, is likely to be more unstable when the equivalent resistance of the next subsystem and the load becomes smaller. So when we set the equivalence resistance to be 20 Ohms, which can reach the largest current for our output, the ripple voltage is large, but still enough when the regulated output voltage is 5 volts.

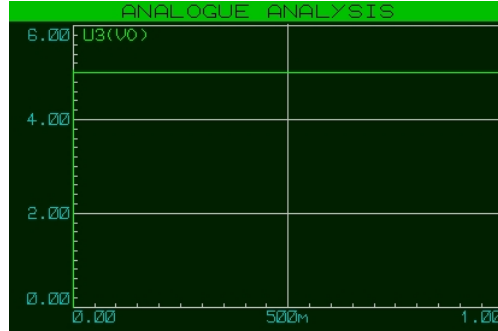

Figure 6: Simulation Result for input of Variable Regulated Power Supply Subsystem

For the output of CJ7805, the output is stable in the simulation however the load and output voltage level changes.

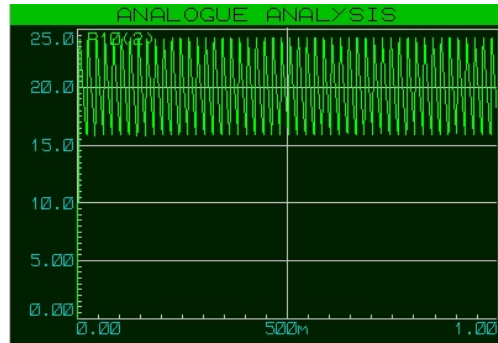

Figure 7: Simulation Result for the output of LM7805

## 2.2 Variable Regulated Power Supply Subsystem

### 2.2.1 Subsystem Overview

The Variable Regulated Power Supply Subsystem serves as a stable and adjustable DC output to fulfill diverse voltage requirements. It includes a Variable voltage regulator from TI or ADI, and variable voltage control circuits for outputting different voltage levels. The role of this subsystem is to provide the main system with a stable direct current power supply with adjustable output voltage. By adjusting the set value, the output voltage can

be flexibly changed within a certain range to meet the requirements of different functions of the overall system.

To meet the charging needs of various small electronic devices such as computers, mobile phones, and tablets, we have initially designed multiple levels of voltage, including 5V, 9V, 12V, 15V and 20V. These levels can be easily and flexibly controlled and adjusted. Additionally, to minimize the impact of different loads on the output voltage and other environmental interference, we consider to design a feedback circuit that detects the input and provides regulated voltage to achieve higher precision.

- **Variable Voltage Regulator:** Integrated circuits designed to provide a regulated output voltage that can be adjusted or programmed to a desired level. These regulators typically accept an input voltage and deliver a regulated output voltage, which can be set within a specified range using external resistors or digital control interfaces.
- **Variable voltage control circuits:** Electronic circuits designed to control or adjust the output voltage of a power supply or voltage source.
- **Sampling circuit:** Reads the voltage and current information from the output port.
- **Display circuit:** After sampling voltage from the output, performing analog-to-digital conversion, the voltage will be read through STM32 by encoding, and displaying the value on the OLED display screen for our convenience to understand the existing output voltage value.

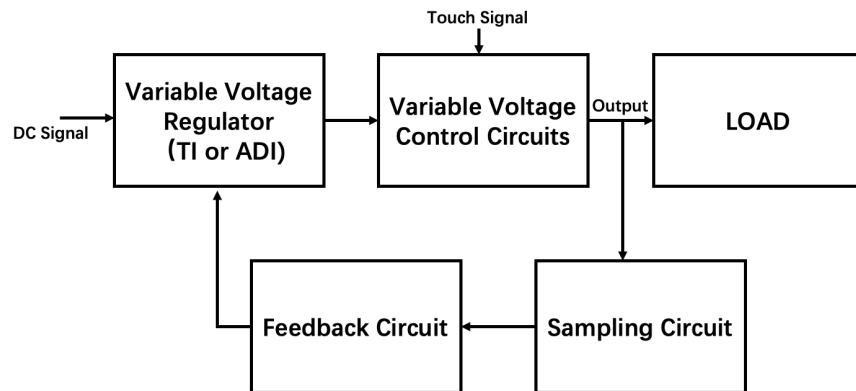

Figure 8: Regulated Power Subsystem block diagram

For switching between different voltage levels, we've gathered numerous research papers and reference materials. Initially, we considered using a voltage divider by resistances and relay-controlled switches. And here is the circuit:

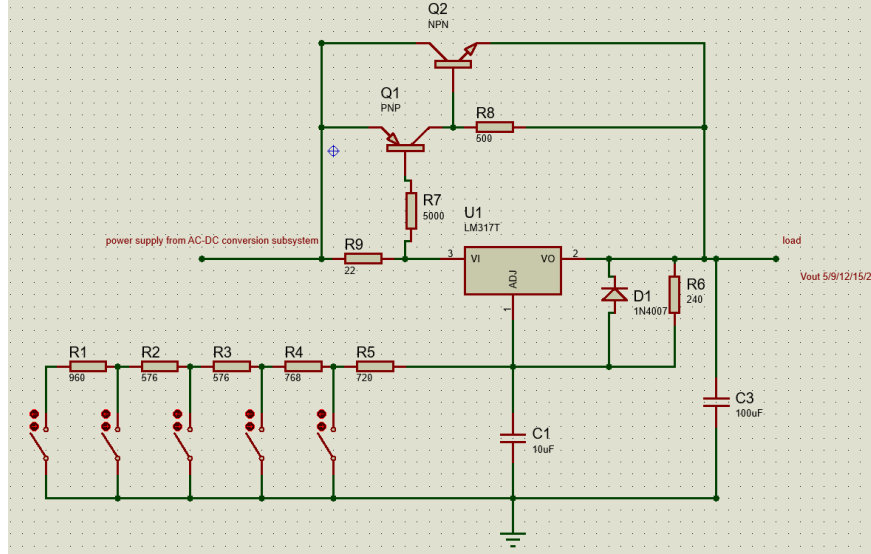

Figure 9: Resistances Control Circuit

However, after exploring the feasibility of PWM(Pulse Width Modulation) converters' equivalent series resistance[8], we opted for a solution that involves using PWM to control the duty cycle and thereby modify the equivalent resistance. The benefit of PWM is that it allows for adjusting the duty cycle based on the output after the circuit is completed, thereby achieving more precise output voltage. This enables functions such as fine-tuning and feedback to be implemented.

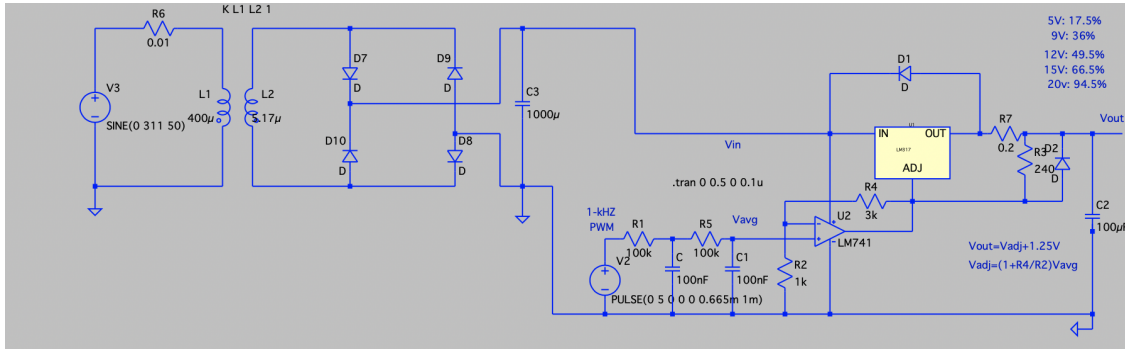

Figure 10: PWM Control Circuit

### 2.2.2 Component Selection

In order to meet the supply requirements for the AC-DC end, as well as achieve a maximum output voltage of 20V, we need to select a regulator with an input voltage range greater than  $18 \cdot \sqrt{2}$  V, adjustable output voltage, and a certain current carrying capacity. After comparing various regulators, we have chosen the LM317, which has an input voltage range of 4.25-40V. The LM317 is capable of supplying more than 1.5A across an output voltage range of 1.25V to 37V. This device exhibits a typical line regulation of 0.01% and typical

load regulation of 0.1%. It incorporates features such as current limiting, thermal overload protection, and safe operating area protection[9].

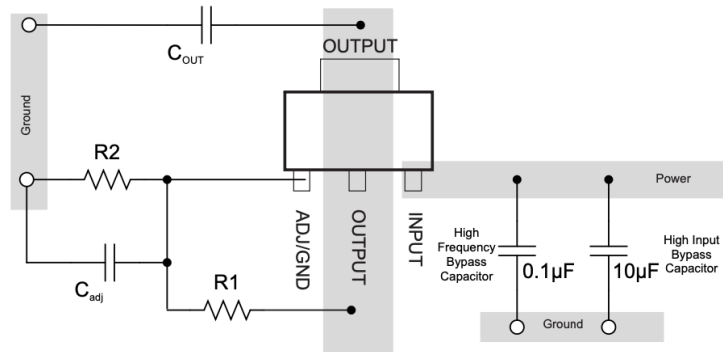

Figure 11: LM317 layout example

For Resistances based Circuit, the output voltage depends on the resistance value of the access circuit:

$$V_{\text{out}} = \left(1 + \frac{R_x}{R_6}\right) \cdot 1.25 \quad (5)$$

Due to the limitations of standard resistors and potential impedance issues with other components in the physical circuit, we have replaced the voltage divider resistors with a variable resistor (potentiometer) to facilitate further adjustments after PCB fabrication.

For PWM based Circuit, the output voltage depends on the duty cycle of PWM:

$$V_{\text{out}} = V_{\text{adj}} + 1.25V \quad (6)$$

$$V_{\text{adj}} = \left(1 + \frac{R_4}{R_2}\right) \cdot V_{\text{avg}} \quad (7)$$

Due to the relatively low voltage of the PWM output, we have implemented an operational amplifier to amplify the voltage after PWM rectification, thereby achieving the desired output voltage level.

For the generation of PWM signal, the display of output voltage on OLED, and LED to indicate the voltage level, we use MCU (STM32F103) to realize the functions.

The STM32F103C8T6 is a microcontroller from the STM32 family of 32-bit ARM Cortex-M3 microcontrollers developed by STMicroelectronics, which operates at a frequency of up to 72 MHz. This particular model is known for its balance of performance, power efficiency, and versatility, making it popular in various embedded system applications[10].

STM32F103C8T6 has rich I/O capabilities, including multiple GPIOs (General-Purpose Input/Output), ADCs, timers, and communication interfaces. The features we use for these projects include:

First, PWM Generation: The microcontroller can generate PWM signals through its advanced timer modules.

Second, ADC Capabilities: It includes a 12-bit ADC for precise voltage measurement.

Third, GPIO Flexibility: Numerous GPIO pins for handling inputs (buttons) and outputs (LED indicators).

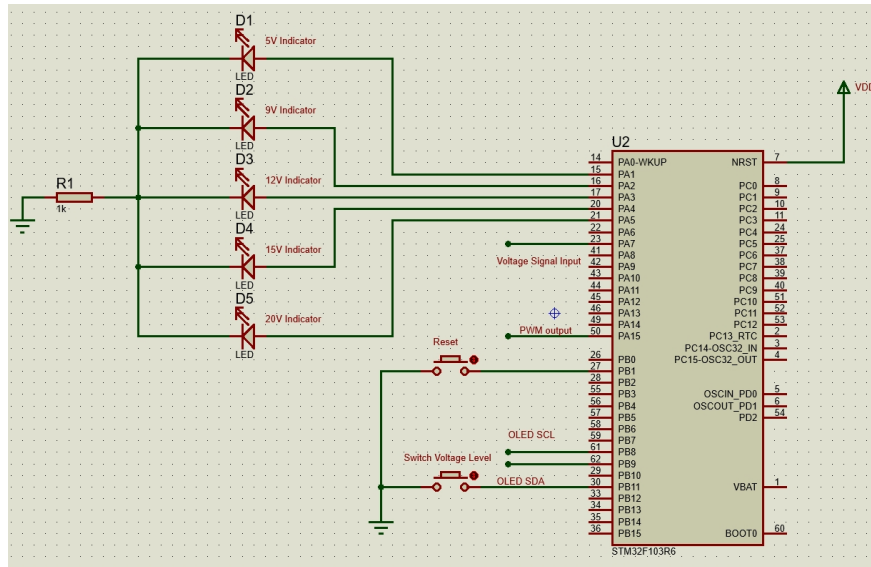

Figure 12: Circuit Schematic for STM32

For the key control, we use STM32 to read the state of a push button through a GPIO pin configured with a pull-up resistor. The STM32 includes internal pull-up resistors that can be enabled via software. When the pull-up resistor is enabled, it connects the input pin to a high logic level ( $V_{cc}$ , typically 3.3V) through a resistor. When the push button is not pressed, the GPIO pin is pulled high to  $V_{cc}$  through the internal pull-up resistor. The microcontroller reads this state as a logic high. When the push button is pressed, it creates a direct path to ground (GND).

To control an LED, a GPIO pin is configured as an output. This allows the microcontroller to drive the LED by supplying voltage (high state) or grounding it (low state).

For PWM signal generation, The STM32 has several timers that can be configured for PWM output. Each timer can control multiple channels, allowing several PWM signals to be generated simultaneously. The specific GPIO pins used for PWM output need to be configured in alternate function mode to connect them to the timer output channels. In the design, we choose the timer TIM2 and the GPIO pin PA15 to generate a PWM signal. The PWM pin (PA15) is configured in alternate function push-pull mode to route the timer output to the pin.

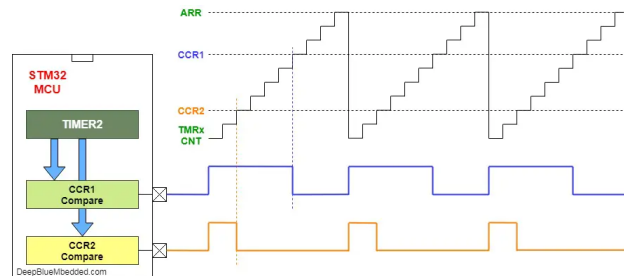

Figure 13: Circuit Schematic for STM32

We set the frequency, resolution, and duty cycle of PWM by initiating the corresponding registers:

Period (ARR - Auto-Reload Register): Defines the period of the PWM signal.

Prescaler (PSC): Divides the timer clock to achieve the desired PWM frequency.

Duty Cycle (CCR - Capture/Compare Register): Determines the high time of the PWM signal within one period.

To set the parameters, the formulas are:

$$Frequency = CK\_PSC \div (PSC + 1) \div (ARR + 1) \quad (8)$$

$$DutyCycle = CCR \div (ARR + 1) \quad (9)$$

$$Resolution = 1 \div (ARR + 1) \quad (10)$$

To display the output voltage value, we need to first perform analog-to-digital conversion. The STM32 has a built-in ADC, whose working principle is basically the same as that of the ADC0809. The ADC0809 is a widely used Analog-to-Digital Converter (ADC) that translates analog signals into digital data. It is an 8-bit converter, meaning it can represent an analog input with 256 discrete digital levels. For the internal STM32, the reference voltage is its 3.3V power supply input. Therefore, we need to reduce the measurement voltage range to within 3.3V. We simply used the high-resistance voltage divider method.

Through the AD conversion, we can obtain the actual value of the output voltage, so we can compare this value with our set output value, and thus control the PWM duty cycle to adjust the output voltage, achieving the purpose of feedback regulation.

The purpose of the OLED display is to display the output voltage on the OLED large screen for the user to read.

### 2.2.3 Simulation

For Resistances based Circuit, the output voltage depends on the resistance value of the access circuit:

$$V_{out} = \left(1 + \frac{Rx}{R6}\right) \cdot 1.25 \quad (11)$$

Due to the limitations of standard resistors and potential impedance issues with other components in the physical circuit, we have replaced the voltage divider resistors with a variable resistor (potentiometer) to facilitate further adjustments after PCB fabrication.

For PWM based Circuit, the output voltage depends on the duty cycle of PWM:

$$V_{out} = V_{adj} + 1.25V \quad (12)$$

$$V_{adj} = \left(1 + \frac{R4}{R2}\right) \cdot V_{avg} \quad (13)$$

$$V_{adj} = V_{out} - 1.25V \quad (14)$$

$$V_{rms} = \frac{V_{adj}}{6.7} \quad (15)$$

$$Duty\ cycle = \frac{V_{rms}}{3.3V} \quad (16)$$

Based on the above calculations, we can obtain the values of the PWM duty cycle under different set voltage levels. We generate the corresponding PWM waveform using the STM32 single-chip microcontroller, and then after rectification and amplification, output it to the adjust pin of the LM317 voltage regulator.

For resistance based circuit, we've done some simulations. We have observed that the stability of the output is easily affected by the load size. Under a current of 1A, the output voltage remains relatively stable, with slight fluctuations at 20V. Due to the power limitations of the transformer, we are unable to achieve a high output current.

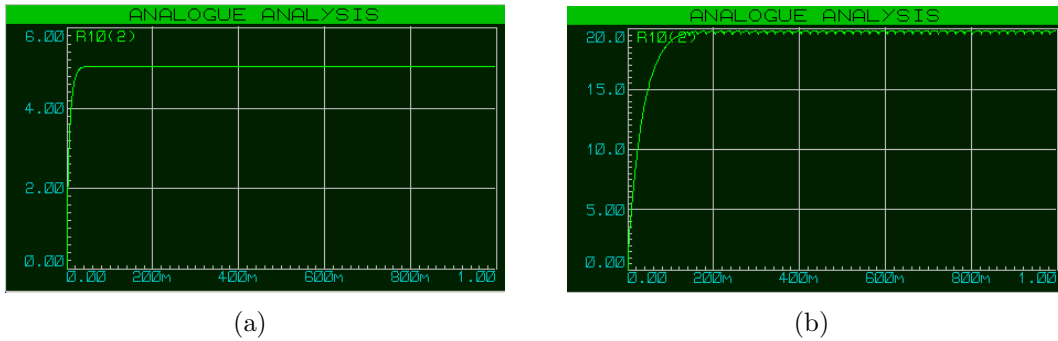

Figure 14: Resistance based Circuit for 5V 1A(a) and 20V 1A(b)

For PWM based circuit, we will get a 21.28V output when duty cycle is 1. We have observed a slight offset in the output voltage, which could be attributed to some losses during the filtering process, as well as a certain level of offset in the operational amplifier.

Then we adjust the duty cycle to let the output voltage meet the voltage level we need. The following two figures show the voltage of 5V and 12V. The results are quite stable.

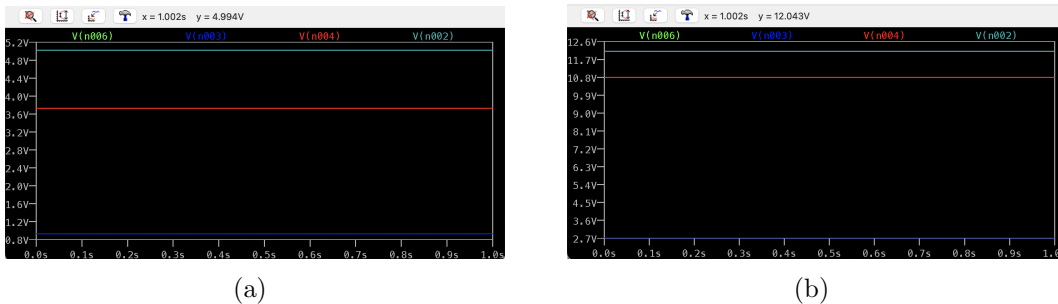

Figure 15: Output Voltage = 5V(a) and 12v(b)

## 2.3 Touch Control Subsystem

### 2.3.1 Design procedure

The Touch Control Subsystem is intended to allow touch-sensitive controls for user interaction. It includes touch sensors (touch plate), digital IC, and other circuits to produce

control signals for the variable voltage control circuits. This subsystem can achieve the transition between different states through programming and digital logic circuits. It recognizes input signals and processes them to provide corresponding outputs.

To realize this function, researches about which kind of touch sensor should be selected were done first. There exists lots of touch control module. Resistance sensor, capacitance sensor, pressure sensor are possible solutions. Resistance sensor was excluded first because its sensitivity is too low to meet the requirements of the reaction time. Pressure sensors have poor stability and are easily affected by temperature and electromagnetic interference. Given those reasons, capacitance sensor was selected for the design.

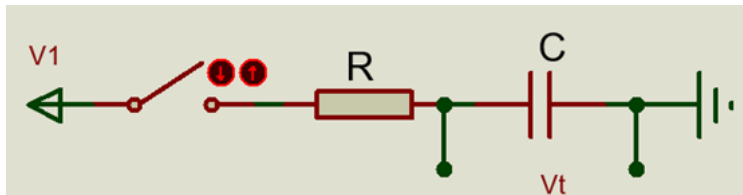

Figure 16: RC charge-discharge circuit

This is a simple RC charge and discharge circuit. When the switch is closed, the capacitor starts to charge, and initially, the voltage across it is zero. The current flow is at its maximum at this point, as determined by Ohm's law:

$$I = \frac{V}{R} \quad (17)$$

As charge accumulates on the capacitor plates, the voltage across the capacitor gradually increases, while the voltage across the resistor decreases accordingly. The current through the circuit decreases as the capacitor charges up, following the relationship:

$$I = \frac{V_1 - V_t}{R} \quad (18)$$

Eventually, when the voltage across the capacitor reaches the same value as the applied voltage, the current in the circuit becomes zero, indicating that the capacitor is fully charged. This process can be represented mathematically by the charging equation for a capacitor in an RC circuit:

$$V_t = V_1 \left( 1 - e^{-\frac{t}{RC}} \right) \quad (19)$$

Conductive objects exhibit capacitance between them. The size of this capacitance is influenced by the conductivity of the medium, the dimensions of the objects, and the presence of conductive materials in the surrounding environment. On printed circuit boards, large solder pads and adjacent ground form distributed capacitance  $C$ . When a finger touches the button, the capacitance of the human body interacts with the distributed capacitance, increasing the total capacitance and causing a change in capacitance.



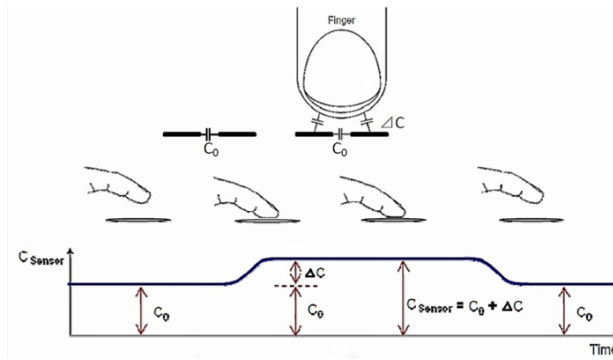

Figure 17: Basic principles of touch sensor

A touch sensor and microcontroller pins form a continuously charging and discharging RC circuit. If the button is not touched, the RC circuit operates according to a fixed charging and discharging cycle. However, when the button is touched, the equivalent capacitance  $C$  increases, leading to an extension of the charging and discharging cycle, thus reducing the frequency. Typically, to determine whether the capacitive button is pressed, integrated circuits collect the number of pulses within a fixed time period, subtracting it from the number when the button is not pressed, and finally identifying the pressing and releasing of the button based on a defined threshold (such as the CH554 series).

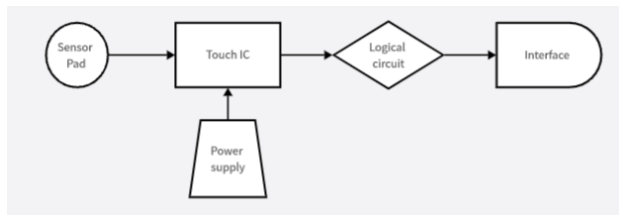

Figure 18: Block diagram of touch control circuit

### 2.3.2 Design details

It's time to seek for IC that applies touch control. Several kinds of IC was browsed, among them, TTP223-BA6 and RH6015C are the most practical chips among various situations. After talking with the chip supplier, we found that the TTP223-BA6 chip was not available. So I made the choice to apply RH6015C for our board. Using the RH6015C chip in PCB design offers several advantages. Firstly, it simplifies the design process by integrating the main functional modules required for touch detection, including sensor interfaces, signal processing, and detection algorithms. Secondly, the RH6015C occupies a small footprint on the PCB, aiding in designing more compact touch modules. Additionally, it is easy to integrate with other system components, providing standard interfaces and communication protocols. Moreover, the RH6015C is designed with power optimization in mind, enabling low-power operation, thereby extending battery life or reducing energy consumption. Most importantly, as a chip designed specifically for touch applications, the RH6015C offers high

sensitivity and stability, enabling accurate touch detection and response, providing users with an excellent touch experience.

Pad Number	Pad name	Pad description
1	TCH	CMOS output
2	GND	Negative power supply,ground
3	OC	Input sensor port
4	TOG	Output type selection,1 for toggle mode,0 for direct mode.
5	VDD	Positive power supply
6	AHLB	Ouput active or low selection,1 for active low,0 for active high

Table 1: Pads description

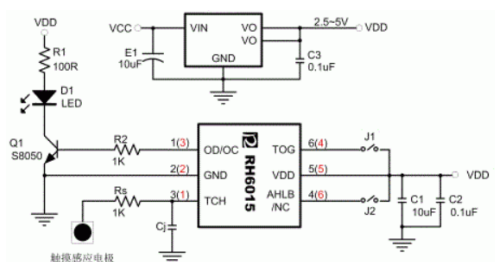

Figure 19: Application circuit of RH6015C

The first challenge is that touch control circuit is hard to make simulation on the computer. One of the main reasons why touch chips are difficult to simulate easily in simulation software is their complexity. Touch technology involves multiple physical processes, including changes in capacitance, electric field sensing, signal processing, etc., the interaction of which makes simulation complex and challenging. Additionally, touch chips typically require interaction with external environments (such as the human body), which adds to the complexity of simulation, as simulation software may not accurately simulate this interaction process.

So for substitute, I applied some basic components to simulate the touch IC and I use a capacitor to simulate human finger capacitance. I complete my simulation on proteus.

In this simulation, U1:B and U3:A is applied as voltage follower and U1:A is a comparator. A clock signal is connected to the circuit. The entire circuit works by comparing the output waveforms of parts C1 and C2. When the switch button representing the human finger is pressed, C3 is connected to the circuit, and the waveforms of channel A and channel B are different, the comparator will change the output. U2: A is used as a latch to simulate the self-locking mode that the chip can generate.

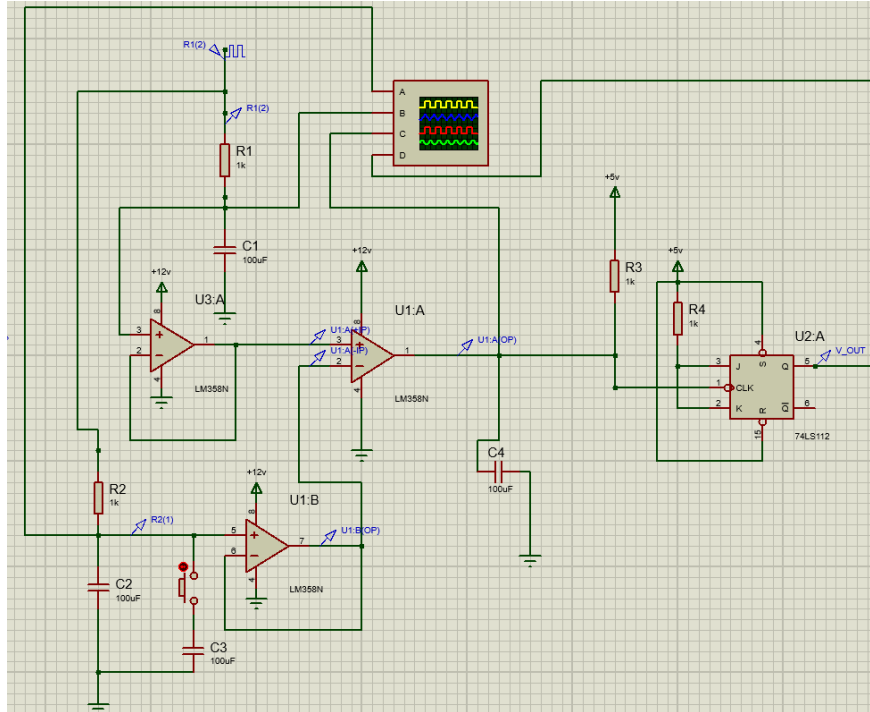

Figure 20: Simulation Circuit on Proteus

You can see from the simulation that when the button is pressed, channel A and channel B shows a difference and channel C goes down to 0 instantly for once. And channel D as the output stays stable as 5V, and after click the button once again, channel D goes to 0V again.

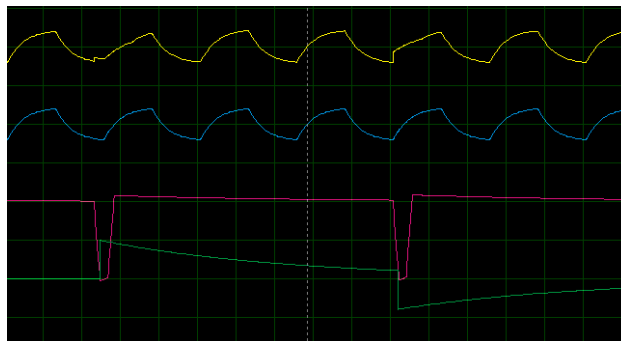

Figure 21: Result of simulation

And for the interface part, there was two choices, relay or the triode. Due to the high power consumption of the relay, I chose the triodes as my final interface switch part. SS8050 was the one of a NPN triodes that was selected for the control part.

The base-emitter saturation voltage 1.2V according to the datasheet of SS8050, which means a 1.2V volt will make the line between collector and emitter connected, which satisfy our demands. With those components, we drew the schematic together, and this is touch control circuit subsystem.

And the schematic goes like this.

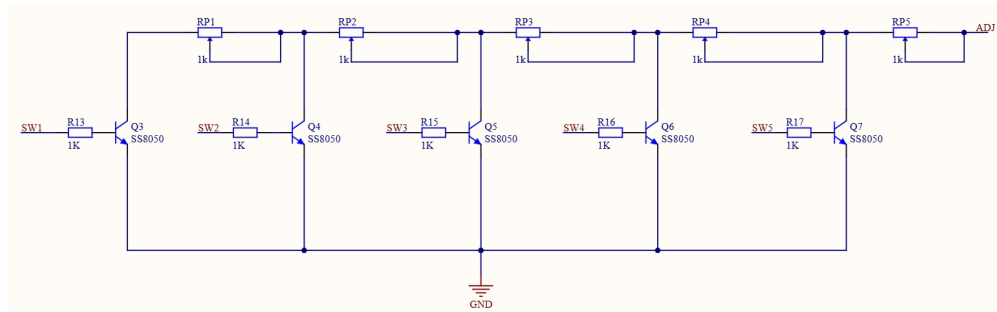

Figure 22: Interface schematic of Touch Control

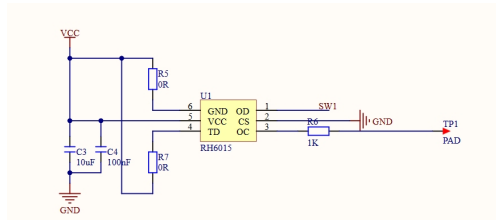

Figure 23: Touch schematic

There are some important matters when turning a touch circuit schematic into PCB document. Power and ground traces should be routed parallel to each other, with lines of equal width and spacing wherever possible. This serves the purpose of utilizing capacitive filtering and reducing common mode interference. A ground plane should be retained as much as possible on the power supply end. Additionally, the area of the ground trace should be greater than that of the power supply trace to shield against external interference signals. For the traces from the TK pad to the MCU touch pin, they should be kept short and thin. When there are multiple key traces, the lengths of the traces from the TK pad to the MCU touch pin should be made as consistent as possible. The key sensing pad must be tightly attached to the panel without any air gap in between to maintain stable sensitivity. Failure to tightly adhere the key sensing pad to the panel can result in decreased sensitivity and reduced interference resistance. Pads should be circular with a diameter of approximately 8mm.

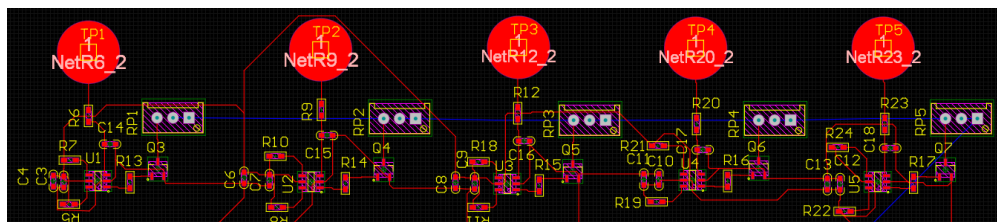

Figure 24: PCB layout of touch

## 2.4 Protection Subsystem

### 2.4.1 Design Procedure

The primary objective of the Protection Subsystem within our project is to maintain the integrity and safety of both the circuitry and connected appliances by effectively detecting and averting short circuits. In scenarios where an unforeseen event occurs, this subsystem acts swiftly to cut-off or short the corresponding part, and stabilize voltage and current, thereby shielding the circuit and the end-user from potential harm. It involves determining the suitable levels for current and voltage based on the specific needs of the application at hand. To ensure the dependability and sustained stability of the electrical circuit, it is imperative to consider elements such as temperature rise and safety margins during this process. There are four alternatives as follows.

- **Integrated Relays:** It monitors the current and voltage of the circuit, in order to control the circuit to open and close to protect the circuit.
- **Circuit Signal Control:** That is using analog data transmission, the current or voltage in the circuit can be converted into these standard analog signals through corresponding sensors and transmitters, and then read and transmitted through a data acquisition system(such as PLC).
- **PCB Protection Components and Modules:** Such as gas discharge tubes, NTC resistors, varistors, TVS, etc. in PCB design software to achieve protection.
- **Supplementary Minimum Protection Standard:** To use self restoring fuses soldered into the circuit to provide at least the most basic protection at the physical level.

While our design should have practical value and reasonable cost control, rather than adding redundant and complex functions to meet course requirements. So the first two solutions were abandoned since though they require more professional knowledge with fancy functions to the product, they go against the original intention of industrial design, with high costs, dominating the components and appearing too cumbersome in the design.

### 2.4.2 Design Details

- **NTC Resistor:** The NTC resistor is connected to the inlet of 220v mains. When the current is over, it will be overheated and disconnected, which is equivalent to an NTC type fuse to protect the port. The NTC 5D-11 resistor is selected here. The NTC 5D-11 type resistor is selected here, the resistance value is 5 ohms, the operating temperature is  $-55^{\circ}\text{C}$   $+200^{\circ}\text{C}$ , and the maximum steady state current is 4A at  $25^{\circ}\text{C}$ , which will not affect the normal circuit operation.
- **Fuse:** After the transformer voltage down, in order to protect the voltage transformer, we connected the BSMD1812-030-60v fuse to avoid the transformer overcurrent. Its maximum voltage is 60v, the trip current is 600mA, and the operating temperature is  $-40^{\circ}\text{C}$   $+85^{\circ}\text{C}$ , which can ensure the operation of the circuit under normal circumstances.

When the output voltage is used, the fuse BSMD1206-100-24v is used to prevent the output short-circuit overcurrent. Its maximum voltage is 24v, the trip current is 1.8A, and the operating temperature is  $-40^{\circ}\text{C} +85^{\circ}\text{C}$ , which can ensure the operation of the circuit under normal circumstances.

- Voltage Regulator Module:** In the positive terminal of  $V_{out}$  and  $V_{cc}$ , the voltage regulator module CJ7805 is used respectively to avoid excessive voltage. Its maximum output current is 1.5A and output voltage is 35v, which can avoid the danger of overvoltage.

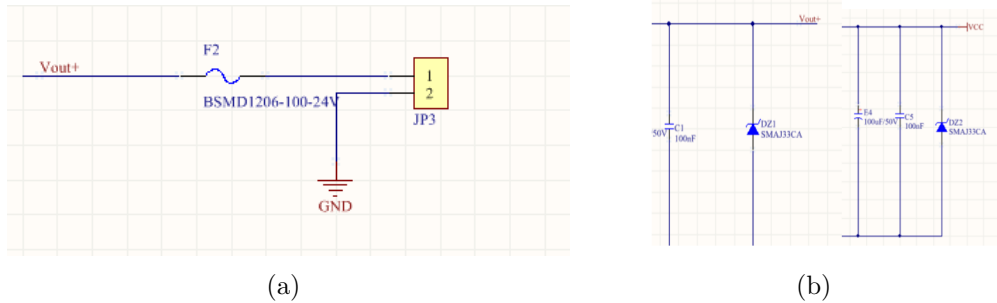

Figure 25: (a)Vout Protection Fuse (b)Stabilivolt CJ7805

- Triode Cut-off:** Q8 of the current expansion circuit has a protective effect. When the current is too large, the voltage at both ends of R4 increases, and Q8 will be switched on, which is equivalent to directly shorting the input and output, and will not supply power to the LM317.

Here, the PNP triode BC640 is selected, the collector current parameter value is 1.5A, the operating temperature is  $-55^{\circ}\text{C} +150^{\circ}\text{C}$ , which can ensure the circuit operation under normal circumstances.

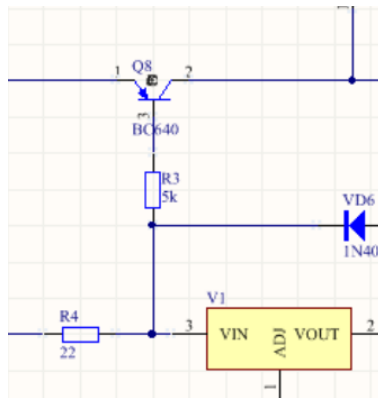

Figure 26: Expanded current circuit protection

### 3 Design Verification

#### 3.1 AC-DC Conversion Subsystem

According to the National Standard of the People’s Republic of China, the 220 V single-phase supply voltage deviation is +7%, -10% of the nominal voltage[11]. The frequency of it should be set to 50Hz[12]. Because it’s hard to measure the actual supply voltage, we did this verification on Proteus, which shows that it has no influence on the final output.

To check the performance and test results of the AC-DC Converter Subsystem, first, we measure the open-circuit output of the subsystem, which is the input of the Variable Regulated Power Supply Subsystem and is essential for the whole project.

The theoretical value should be  $18 \cdot \sqrt{2}V$ , which is about 25V. However, for the transformer manufacturer, the open-circuit output is designed to be slightly larger than the theoretical value to ensure it works properly with a load. So the test value is reasonable.

And for the output of CJ7805, which should be exactly 5V. The test result is perfect and stable. However, because of its high voltage drop, its heat dissipation is large although the current flow through it is very small. So it produces a lot of heat when it works. A cooling blade is needed to reduce risk.

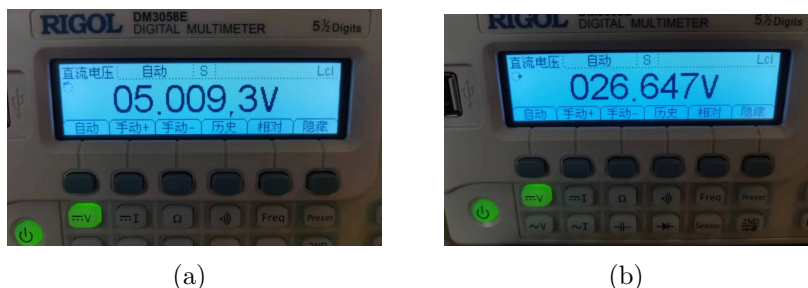

Figure 27: Test Results for the Output of CJ7805(a) and the input to subsequent subsystem(b)

After changing the output current and voltage level within the adjustable range, we can see that the ripple voltage in this subsystem is small enough to ensure the stability of the whole system.

#### 3.2 Variable Regulated Power Supply Subsystem

This subsystem must ensure the output voltage remains within an accurate range ( $\pm 0.1V$ ), without significant interference and fluctuations. We have designed an OLED display screen capable of real-time voltage monitoring, which provides a basic understanding of the voltage ripple level.

When the desired DC voltage value changes, the system needs to respond quickly, and the voltage conversion time must be controlled within a short period. To verify this, we can measure the change in output voltage when the voltage is transformed through the touchscreen and observe the speed of the variation. We can use voltage meter to verify it.

This also can be observed by the OLED display screen. The maximum current can exceed 1A.

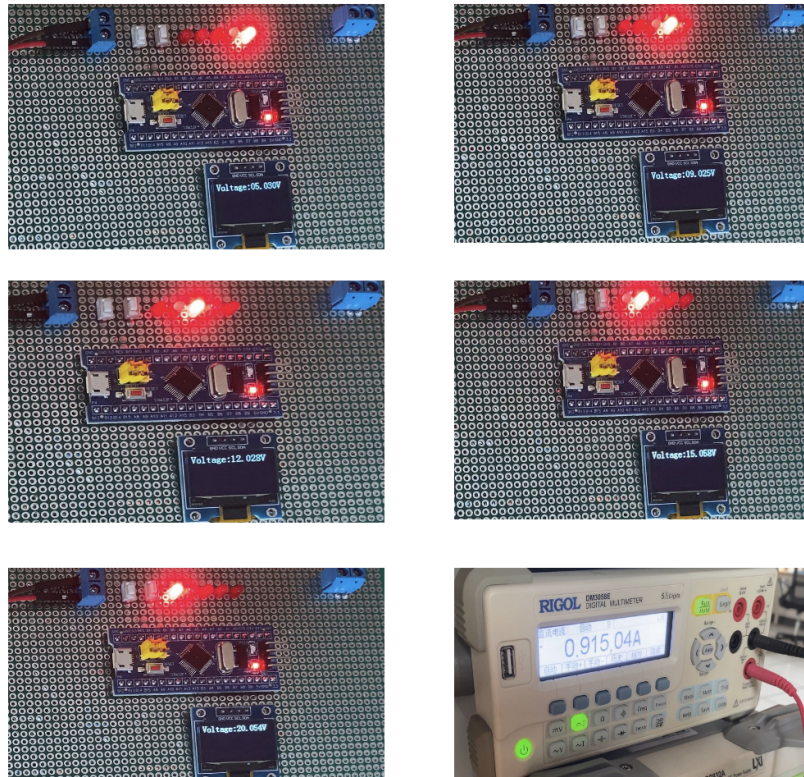

Figure 28: 5 Voltage Levels and Maximum Current

### 3.3 Touch Control Circuit

The response time of the touch-sensitive component should not exceed 80ms, ensuring prompt interaction with user input while effectively filtering out most interference signals not originating from human fingers. Furthermore, it should be capable of triggering the transistor and delivering controlled voltage output. When all five positions of the switch are pressed, the system should respond accordingly at each setting. It should be capable of mitigating the effects of electromagnetic interference, ensuring reliable operation even in environments with high levels of electromagnetic noise. Additionally, it should provide a self-locking mode signal, allowing for signal output to be maintained when pressed and canceled upon a subsequent press.

### 3.4 Protection

In the simulation, we put extreme cases on the transistor of the regulator and the part of the current expansion circuit to verify that it does have the ability to avoid overloading.

However, for the detection of fuses and NTC resistors, due to time constraints and safety concerns, we did not perform extreme tests on physical circuit boards.



## 4 Costs

### 4.1 Cost Analysis

Labor = 30 CNY/h \* 7h \* 12 weeks \* 4 members = 6480 CNY

Component	Amount	Unit Price(CNY)
PNP triode BC640	1	0.28
Fuse-BSMD1206-100-24V	2	0.38
Fuse-BSMD1812-030-60V	1	0.26
NTC 5D-11	1	0.28
Voltstabilizer module CJ7805	1	1.04
TVS-SMAJ33CA	2	0.17
NPN triode TIP35C	1	0.28
Patch resistance 0 Ohms	10	0.007
Patch resistance 500 Ohms	1	0.05
Patch resistance 5k Ohms	2	0.01
Patch resistance 22 Ohms	2	0.003
Patch resistance 1k Ohms	10	0.006
Chip capacitance 10pF	5	0.035
OKey switch	5	0.66
Variable resistance 1k Ohms	5	0.66
Chip capacitance 0.1uF/50V	9	0.014
LM317	1	0.91
Plug-in resistance 240 Ohms	1	0.006
Chip capacitance 10uF	6	0.21
Aluminum electrolytic capacitor 100uF/50V	2	0.54
Aluminum electrolytic capacitor 1000uF/50V	2	2.4
Diode 1N4007	6	0.05
Chip capacitance 10uF	6	0.21
Screw terminal	4	1.03
220-18VAC Transformer 30W	1	26
STM32F103C8T6	1	17
OLED	2	8.9
Total	1	81.41

Table 2: Component Cost

Total cost = Labor + Component Cost = 6561.41 CNY

### 4.2 Schedule

See Appendix A.

## 5 Conclusion

### 5.1 Accomplishments

The safe and stable transformation of 220V AC power into low voltage DC has been successfully achieved. And we have successfully achieved the function of controlling the voltage size of the touch capacitor in five gears, and with considerable sensitivity and stability of practical value. The system is equipped with certain self-protection features. Otherwise, the visualization of the output voltage has been successfully implemented, allowing for a clear and visual representation of the output voltage status.

### 5.2 Uncertainties and Future Work

However, because the circuit design failed to take into account the insufficient output voltage of the touch chip and did not add the efficiency function, we need to connect a comparator amplifier circuit outside the PCB board, and at the same time solve the power supply of this amplifier circuit. This must be improved for the complete product, and if there is time, the future work will be to assemble this part of the circuit on the PCB board.

In our analysis above, we can see that the power loss in the whole system is large. It can be about 80% when the output voltage is 5 volts. And the transformer of large power is heavy and occupies a large area. So the linear power supply may not be a good choice for our design. Maybe the switch power supply is better. We will do more research in the future on the feasibility and design details of the switch power supply circuit.

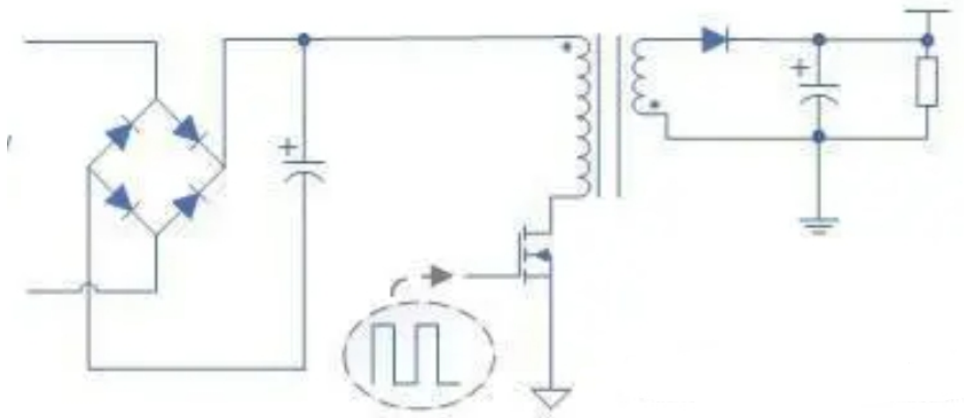

Figure 29: Switch Power Supply Circuit

### 5.3 Ethical Considerations

Undoubtedly, we need to learn many existing code structures and purchase some integrated hardware to implement our functions. So we should pay attention to avoiding

plagiarism and large-scale technology appropriation, and ensuring that the core content of the project is implemented by ourselves.

According to IEEE Code of Ethics[13] and ACM Code of Ethics, we should ensure the DC power supply design is reliable and meets all stated requirements, and consider the societal impact of the technology, ensuring it does not cause harm. We should also respect property rights, including any copyrights or patents related to components used, and properly credit any third-party work or ideas incorporated into the project.

When designing and manufacturing PCB-based power converters, ensuring safety is essential:

- Isolation and encapsulation  
Ensure that all circuits are properly packaged to prevent accidental touching of exposed wires or components.  
Encapsulate the circuit board with an insulating material to prevent short circuits and electric shocks.
- Output voltage and current  
Ensure that the output voltage and current of the converter are within the design range and have sufficient stability.  
Use the appropriate feedback control mechanism in our solution to maintain stable output.
- Overload protection  
We incorporate overload protection circuits in the design to prevent the output current from exceeding the safe value, and use series-capable self-restoring fuses for thermal management.  
We have included a short-circuit protection mechanism in the circuit design to prevent damage when the output is short-circuited.

## 6 References

- [1] Singh, B., Singh, B. N., Chandra, A., Al-Haddad, K., Pandey, A., & Kothari, D. P. (2004). A review of three-phase improved power quality AC-DC converters. *IEEE Transactions on Industrial Electronics*, 51(3), 641-660.
- [2] Malla, S. G., Deepu, D. J., Kumar, D. P., & Malla, J. M. R. (2016, October). Solar powered mobile phone: An innovative experiment. In *2016 International Conference on Signal Processing, Communication, Power and Embedded System (SCOPE5)* (pp. 1015-1020). IEEE.
- [3] Kwon, O. K., An, J. S., & Hong, S. K. (2018). Capacitive touch systems with styli for touch sensors: A review. *IEEE Sensors Journal*, 18(12), 4832-4846.
- [4] Center-tap Full-wave Rectifier, hyperphysics.phy-astr.gsu.edu. <http://hyperphysics.phy-astr.gsu.edu/hbase/Electronic/rectct.html>
- [5] 1N4007 pdf, 1N4007 Description, 1N4007 Datasheet, 1N4007 view ALL-DATASHEET, pdf1.alldatasheet.com. <https://pdf1.alldatasheet.com/datasheet-pdf/view/58825/DIODES/1N4007.html>
- [6] alldatasheet.com. (n.d.). CJ7805 Datasheet(PDF). [Www.alldatasheet.com](http://www.alldatasheet.com). Retrieved May 31, 2024, from <https://www.alldatasheet.com/datasheet-pdf/pdf/138933/JIANGSU/CJ7805.html>
- [7] Lab, M. (2020, July 4). How to use Transformer in Proteus. *Microcontrollers Lab*. <https://microcontrollerslab.com/how-to-use-transformer-in-proteus/>
- [8] Czarkowski, D., Kazimierczuk, M. K. (1992). Circuit models of PWM DC-DC Converters. *Proceedings of the IEEE 1992 National Aerospace and Electronics* <https://doi.org/10.1109/naecon.1992.220539>
- [9] TI.com. (n.d.). LM317. LM317 data sheet, product information and support <https://www.ti.com/product/LM317?keyMatch=LM317&tisearch=search-everything&usecase=GPN-ALT>
- [10] STM32F103C8 - STMicroelectronics. (2019). *STMicroelectronics*. <https://www.st.com/en/microcontrollers-microprocessors/stm32f103c8.html>
- [11] Power quality - Deviation of supply voltage, National Standard of the People's Republic of China GB/T 12325-2008, June 2008. [Online].
- [12] Power quality - Frequency deviation for power system, National Standard of the People's Republic of China GB/T 15945-2008, June 2008. [Online].
- [13] Ethical Requirements - IEEE Author Center Conferences. (2024, January 24). *IEEE Author Center Conferences*. <https://conferences.ieeeauthorcenter.ieee.org/author-ethics/ethical-requirements/>

## A Schedule

Week	Weisong Shi	Chaoli Xia	Yiyi Wang	Sichen Wang
3/4	Learn PCB knowledge and work on the project proposal.	Learn PCB knowledge and work on the project proposal.	Learn PCB knowledge and work on the project proposal.	Learn PCB knowledge and work on the project proposal.
3/11	Learn about Touch control circuit.	Learn about the principle and some common approaches of circuit detection and protection.	Learn the principle under AC-DC conversion and the characteristics of the components.	Learn the working principles of Variable Regulated Power circuit.
3/18	Browse different chips and decide which to use.	Find and consult the corresponding circuit detection and protection components, compare the applicability of parameters.	Create the basic circuit diagram for the AC-DC converter. Do research on the property and requirements of each component.	Search and find feasible solutions that can achieve precise and stable regulation of the output DC voltage.
3/25	Start to build the circuit.	, Analyze the feasibility of each program and discuss with the sponsor.	Continue doing research on the selection of components.	Verify the feasibility of precisely regulating the output voltage through feedback circuits.
4/1	Make the simulation of the circuit.	Make the simulation and logic analysis of the circuit.	Do simulation of the subsystem.	Design the Variable Regulated Power circuit.

Week	Weisong Shi	Chaoli Xia	Yiyi Wang	Sichen Wang
4/8	Start to draw the CAD board.	Insert protection and monitoring parts into the PCB circuit.	Debug and Optimize	Do the simulation of the circuit.
4/15	Purchase item, draw the CAD board.	Purchase the components and integrate them.	Purchase the components. Design the PCB layout of the AC-DC converter.	Purchase item, draw the CAD board.
4/22	Print the PCB and test its functions.	Integrate the protection and detection components and adjust them.	Troubleshoot and Debug	Integrate the subsystems.
4/29	Debug.	Adjust the components and solve the potent risk	Debug. Do final optimization.	Debug.
5/6	Write the essay.	Work on final report	Work on final report	Work on final report
5/13	Prepare for demo.	Prepare for demo.	Prepare for demo.	Prepare for demo.

Table 4: Schedule

## B PCB Layout Design

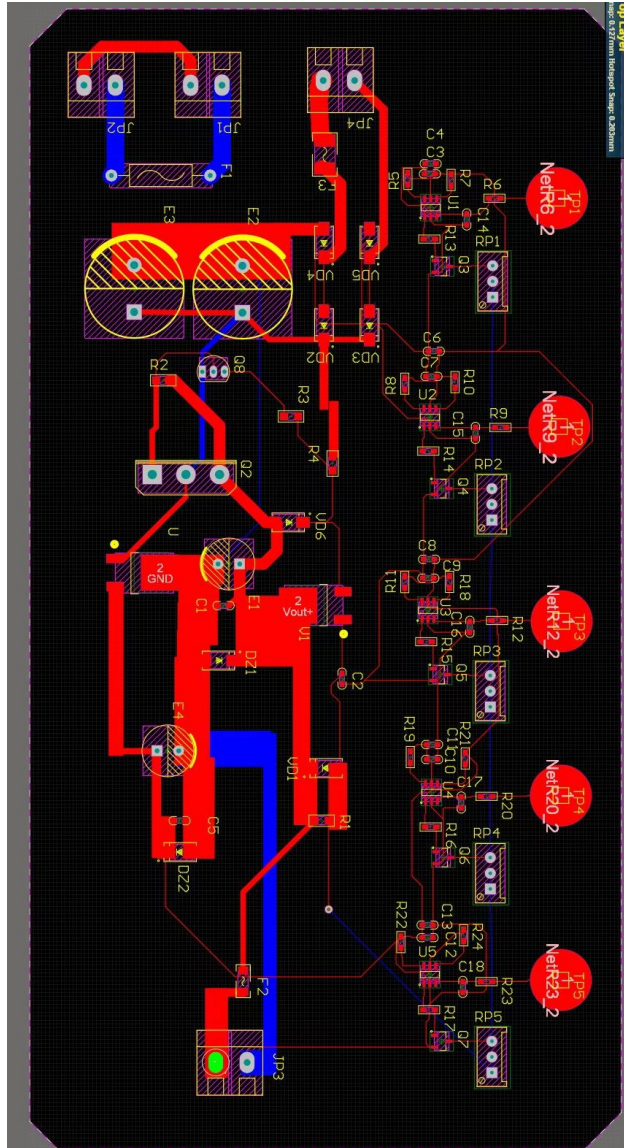

Figure 30: PCB Layout of the Project