

ECE 445  
SENIOR DESIGN LABORATORY  
FINAL REPORT

---

**Project Proposal for ECE445  
Autonomous Transport Car**

---

**Team #24**

ZHIXIN CHEN (zhixinc3)  
ZHUOZHENG HE (zh37)  
XINYUE LU (xinyue15)  
SIZE FENG (sizef2)

Sponsor: Chushan Li  
TA: Yu Dou

May 10, 2024

# Contents

<b>1</b>	<b>Introduction</b>	<b>1</b>
1.1	Purpose . . . . .	1
1.2	functionality . . . . .	2
1.3	Visual Aid . . . . .	2
1.4	Subsystem Overview . . . . .	3
1.4.1	Remote System . . . . .	3
1.4.2	Grab System . . . . .	3
1.4.3	Car System . . . . .	4
<b>2</b>	<b>design</b>	<b>6</b>
2.1	Block Diagram . . . . .	6
2.2	Subsystem Description . . . . .	6
2.2.1	Remote System . . . . .	6
2.2.2	Grab System . . . . .	8
2.2.3	Car System . . . . .	8
2.3	Subsystem Verifications . . . . .	13
2.3.1	Remote System . . . . .	13
2.3.2	Grab System . . . . .	14
2.3.3	Car System . . . . .	15
2.4	Tolerance Analysis . . . . .	16
2.4.1	Endurance Calculation . . . . .	16
2.4.2	Grab Simulation . . . . .	16
2.4.3	Velocity Analysis . . . . .	17
<b>3</b>	<b>Cost &amp; Schedule</b>	<b>20</b>
3.1	Cost . . . . .	20
3.1.1	Labor . . . . .	20
3.1.2	Parts . . . . .	20
3.1.3	Total Cost . . . . .	21
3.2	Schedule . . . . .	21
<b>4</b>	<b>Conclusion</b>	<b>23</b>
4.1	Accomplishments . . . . .	23
4.2	Uncertainties . . . . .	23
4.3	Future Work . . . . .	23
4.4	Ethics Considerations . . . . .	24
4.4.1	Ethics . . . . .	24
4.4.2	Safety . . . . .	24
	<b>References</b>	<b>25</b>

# 1 Introduction

## 1.1 Purpose

In the contemporary era, the convenience and efficiency offered by online shopping have firmly positioned it as the preferred method of purchasing goods for a vast segment of the population. This widespread preference for online shopping brings to the forefront the critical role of express delivery services. However, the process that follows the online purchase, particularly the express delivery and retrieval operations, is predominantly reliant on manual labor. Given the exponential increase in the volume of parcels handled daily, sorting centers and express stations are under significant pressure to employ a substantial workforce dedicated solely to the storage and retrieval of these packages.

For customers attempting to collect their parcels at express stations, the process can be notably cumbersome. Based on the current design of these stations, customers are required to navigate through a maze of complex shelving systems, relying solely on the information provided to them to locate their purchases. This scenario becomes especially chaotic during peak shopping seasons, such as the Double Eleven festival, where the volume of parcels skyrockets. During these periods, express stations become hotbeds of congestion, dramatically reducing the efficiency of package retrieval. Compounding this issue is the frequent occurrence of customers accidentally collecting the wrong packages, a mistake that necessitates additional intervention from express station staff to resolve and reunite lost packages with their rightful owners.

Addressing these challenges necessitates an innovative approach to the storage and retrieval of express deliveries. To this end, our proposal introduces a technologically advanced solution centered around the deployment of robotic arms equipped with precise gripping capabilities, complemented by mobile robotic vehicles. These vehicles, integral to our envisioned system, are designed to streamline the package retrieval process. A dedicated application will play a pivotal role in this ecosystem, dispatching pickup instructions directly to the mobile units. Upon receiving a retrieval request, these vehicles will employ RFID technology to accurately locate the specified parcel within the vast confines of the sorting center. Once the target parcel is identified, the robotic arm mounted on the vehicle will engage, carefully grasping the package with the appropriate level of force to ensure its integrity. Following successful retrieval, the robotic vehicle will then transport the parcel to a designated pickup area, where customers can easily collect their goods.

This proposed system, leveraging cutting-edge technology, aims to revolutionize the current express delivery infrastructure. By automating the retrieval process, we not only enhance the efficiency of parcel collection but also significantly reduce the likelihood of misplaced or erroneously collected packages, thereby streamlining the customer experience during both regular operations and peak periods.

## 1.2 functionality

Our car can receive user information on picking up goods through specific apps. After searching through RFID, the car can obtain the accurate position of the picked goods on the shelf. After planning through the pathfinding algorithm, the car travels to the shelf to prepare for grabbing. The robotic arm of the car will accurately grasp the designated cargo and place it in the cargo box of the vehicle, corrected by the visual recognition algorithm of the camera. After completing the grabbing, the car will drive back to the initial point and then grab the items in the cargo box to the pickup point.

## 1.3 Visual Aid

As shown in Figure 1, users can use the built-in app of the mobile phone to connect to the control board to issue commands to pick up designated goods. The control panel will control the actions of the car and the robotic arm according to the preset programs and goals to complete the goal of grabbing the goods.

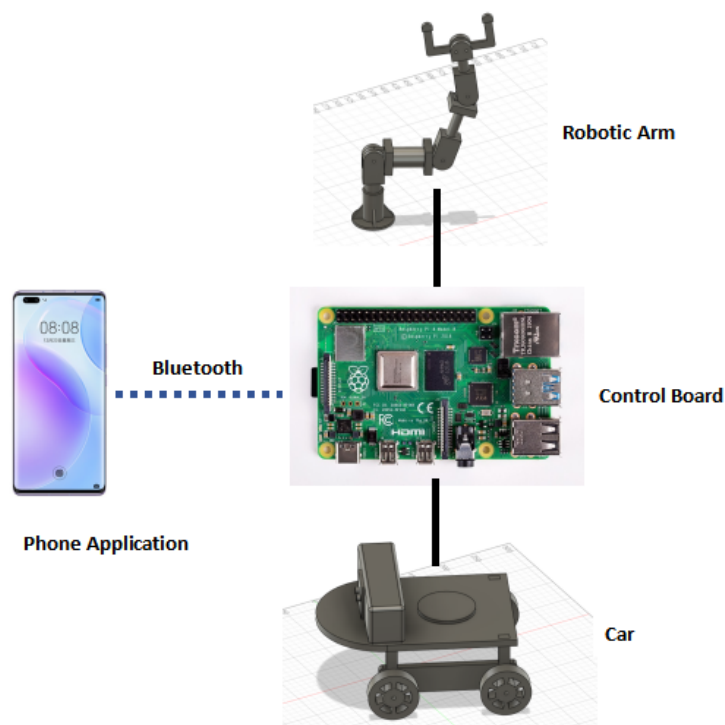

Figure 1: Enter Caption

## 1.4 Subsystem Overview

### 1.4.1 Remote System

The remote system consists of two subsystems: User Interface Subsystem and RFID reader Subsystem.

**User Interface Subsystem:** This is an app that provides users with the option to select the courier they need to pick up. After receiving the package selected by the user, the specific information will be transmitted to the RFID reader subsystem.

**RFID reader subsystem:** RFID reader is a device used to communicate with a tag on an item. RFID reader sends radio signals around and receives a response from the tag to determine the exact location of the good on the shelf. Then the control system receives the data from the RFID reader.

#### **Operation Process:**

The control subsystem mounted on the car communicates with a Bluetooth module and a mobile app.

For the operation of searching for items, the RFID module communicates with the control subsystem on the car through a serial port. After receiving the cargo information from the control subsystem. The RFID receiver starts working and will search for all tags. The label contains information about the goods and the location of the shelf. Therefore, the RFID receiver can determine the location of the goods that need to be searched. Then pass it back to the control subsystem.

For the operation of storing items, after completing the placement of the goods, modify the RFID tag information carried by the goods.

### 1.4.2 Grab System

The Grab system mainly consists of two independent components: **end-effector, servo**.

The mechanical structure of a robotic arm consists of 4 joints, each of which is connected to an arm segment which is made of rigid material and forms in a chain-like structure.

For the first joint, it is used to control the whole robotic arm. This joint is driven by a servo located at the bottom of the robotic arm and used to rotate the whole arm. For the rest of the joints, they are used to control arm segments and driven by servos to rotate at the specific plane. To combined them together, the robotic arm will be able to reach to the exact location in three-dimensional space.

An end-effector is attached to the end of the robotic arm to perform the task of grabbing the good. To grab the good tightly, there are rubber bushings on the end-effector to increase the friction between the effector and the good.

For the servos, we use ZP series servos which can achieve precise angle control. The accuracy of the servo can reach 0.3 degree. The control method of servo is serial port and PWM.

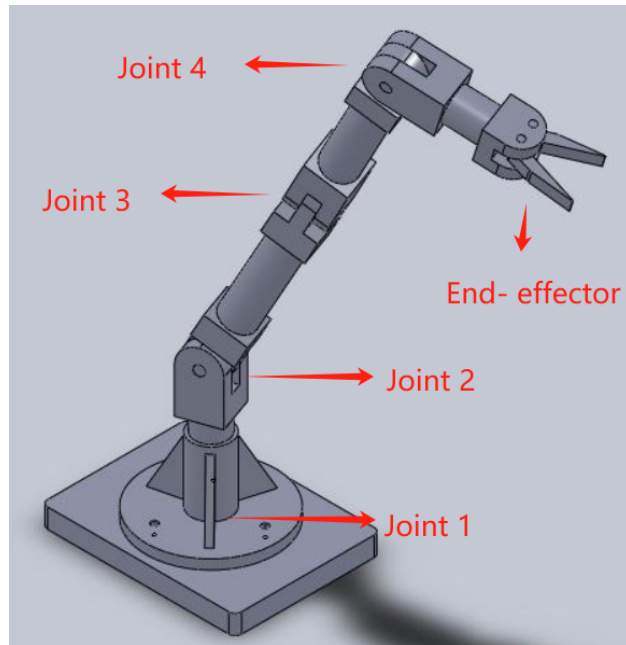

Figure 2: Robotic Arm

### Operation Process:

When the cart reaches the shelf of the specified product according to the black line on the ground, the control system receives the data from the RFID reader, calculates the trajectory of the whole robot arm on the car and control the end-effector to grab the good we want. The whole process is supported by several servos located at every joint on the robot arm. Each joint on the robot arm can be rotated or moved in a straight line in 3D coordinate system.

### 1.4.3 Car System

The car system mainly consists of three independent subsystems: **control subsystem**, **tracking subsystem** and **obstacle avoidance subsystem**.

The control subsystem includes the STM32 control board and the Raspberry Pi control board, which are used for central scheduling of the work of various subsystems.

The pathfinding and obstacle avoidance functions are achieved by a depth camera, where the pathfinding function is achieved by the camera following the black line, and the obstacle avoidance function is achieved by the visual camera recognizing the object in front of it.

### Operation Process:

After the car system receives destination instructions from the control system, the tracking subsystem will find the best route based on the stored map. The movement of the car will follow the black line. During walking, the visual obstacle avoidance system of the

car will recognize whether there are obstacles or other cars ahead. After arriving at the designated location and waiting for the Grab system to complete the grabbing operation, the car will find the best route again and return to the pickup point.



Figure 3: Car

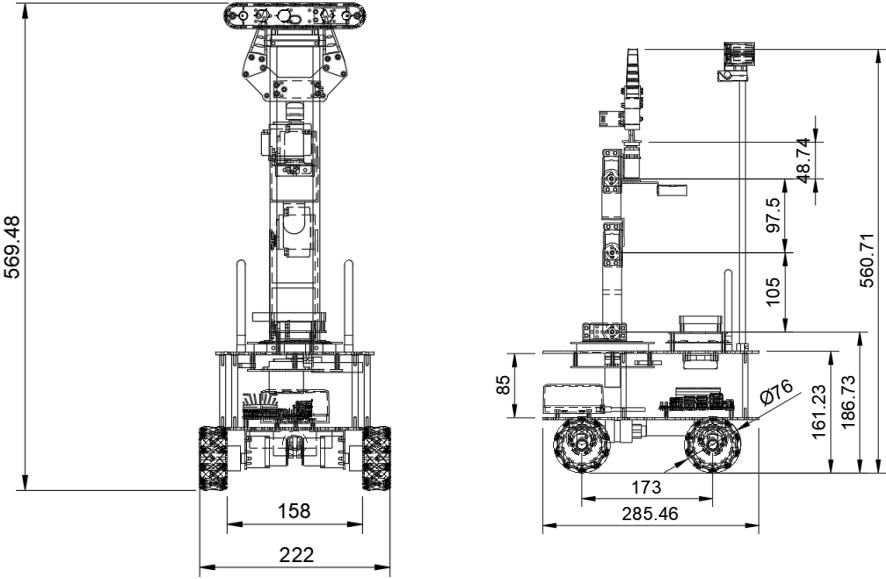

Figure 4: Dimensions of the car

## 2 design

### 2.1 Block Diagram

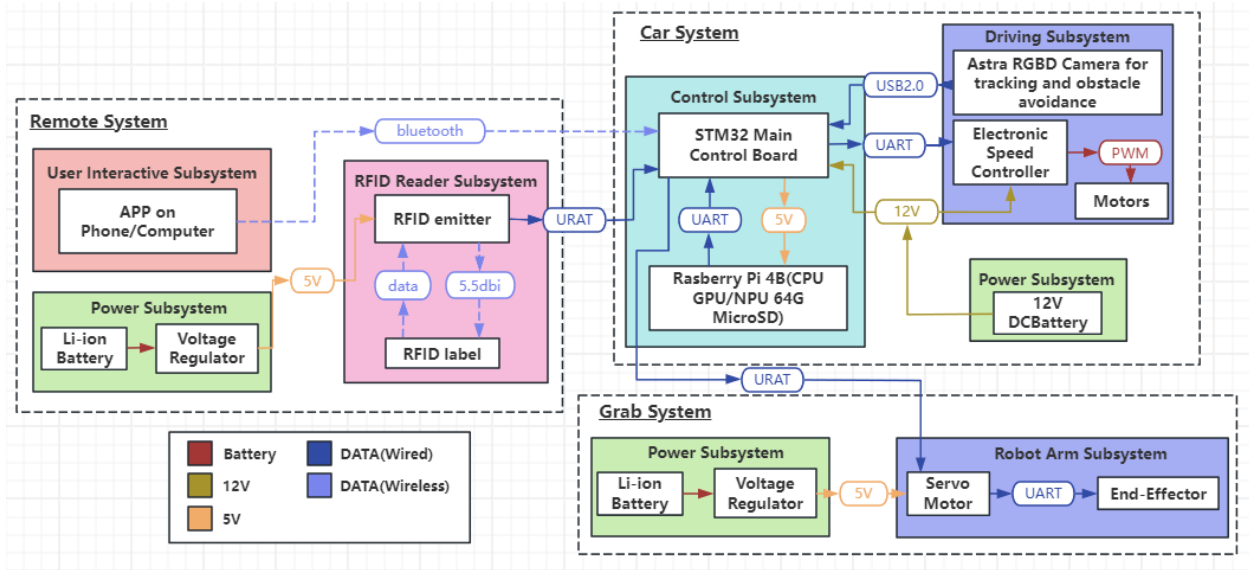

Figure 5: Block Diagram

### 2.2 Subsystem Description

#### 2.2.1 Remote System

##### RFID reader and writer subsystem

In order to be able to find the specified goods, the FM-508 chip provides the ability to read and write RFID tags. As shown in the table 1 below, after providing power to the VCC side, providing specific inputs to the RX side allows it to complete the operations of reading and remote writing tags. And the required output can be obtained at the WX side.

Parameter	Min	Typ	Max	Unit
Power Supply Voltage	3.6	5	5.5	V
Storage Temperature	0	-	+50	°C

Table 1: FM-508 chip

##### Display Module

We used TM1638 as the driver chip to design a digital display screen suitable for our car. TM1638 is an LED (Light Emitting Diode Display) driver control IC with keyboard scanning interface, which integrates MCU digital interface, data latch, LED driver, keyboard scanning and other circuits internally. Below is the PCB Design.



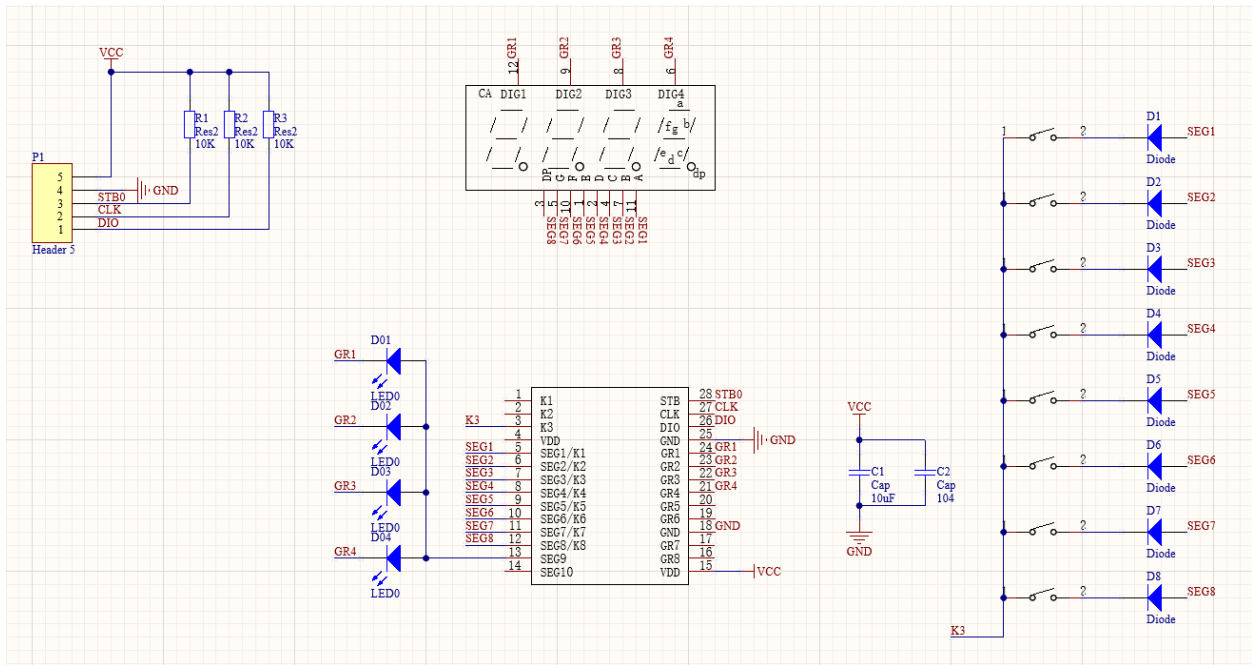

Figure 6: Schematic

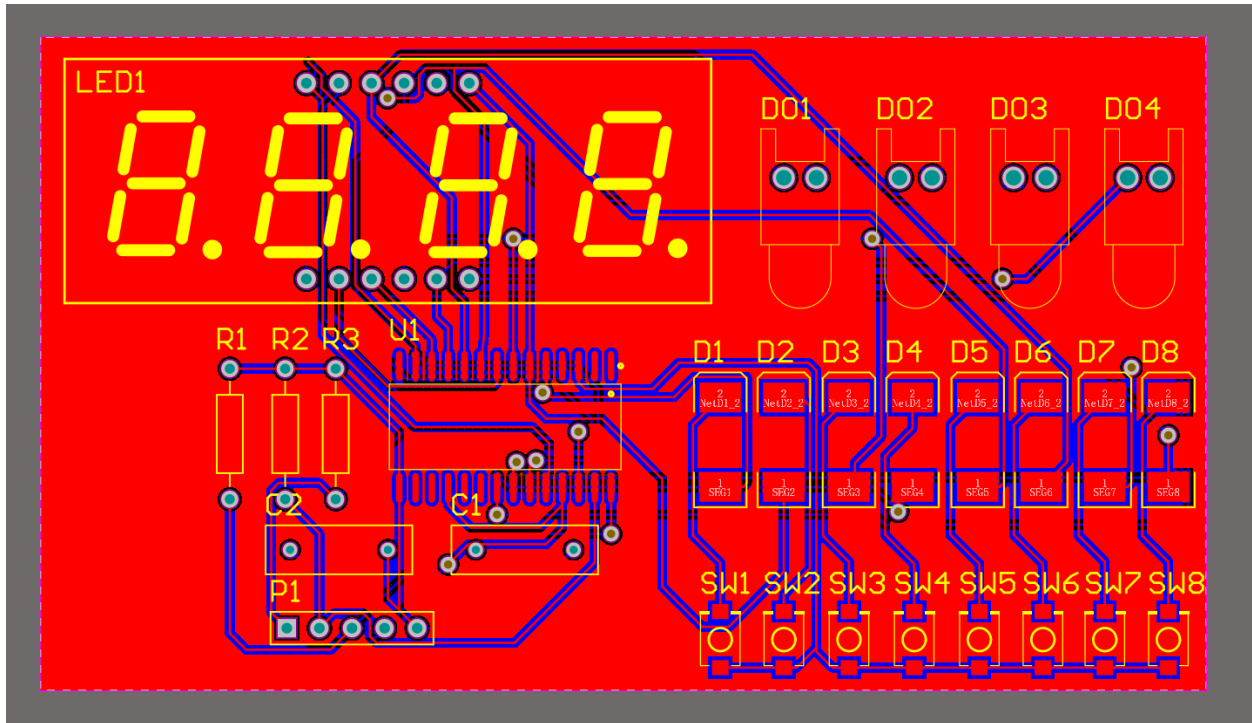

Figure 7: PCB Design

## 2.2.2 Grab System

### Adapter plate for manipulator

To control the manipulator with control board and use servos to drive the manipulator to grab goods, PCA9685 chip is used to design an adapter plate for manipulator since it can control 16 PWM signal outputs to achieve precise control of servo motors. As shown in figure 6, we use PCA9685 to control the position of servos and provide stable voltage supply to PCA9685 chip. To communicate with main control board, H1 is used to output PWM signal and J1 is used to communication. In order to provide power for servos and other electrical components of manipulator, as shown in figure 7, the upper adapter plate is designed.

### Servos

In order to realize the working of the robotic arm at all angles, we choose S20F 270° digital servo with 270° operation angle. Parameters of the servo are shown in table 2 and figure 8.

Operating voltage	5V 6.5V
No-load current	80mA (5V)
No-load RPM	0.18 sec/60° (5V), 0.16 sec/60° (6.5V)
Blocking torque	20kg·cm (5V), 23kg·cm (6.5V)
Blocking current	1.8A (5V)
Standby current	4mA (5V)
Reduction ratio	268:1
Physical dimension	40mm×20mm×40mm
Weight	62g
Pulse width range	500 → 2500 sec
Operation angle	270°

Table 2: Parameter of S20F 270° digital servo

## 2.2.3 Car System

### Lithium Battery

The power supply of the main control panel is 12V 0-3A 5600mAh Lithium Battery, which can meet the requirements of motors and other components. It is storage battery with Battery charging/discharging connector: DC 5.5-2.1 terminal female. Table 3 shows the performance of the battery.

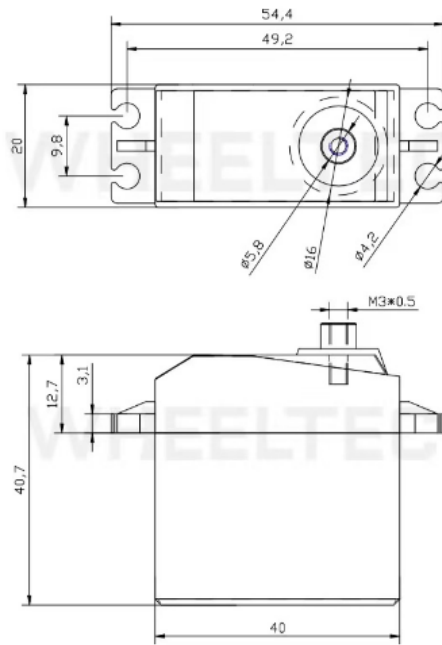

Figure 8: Dimensions of servo

Function	Performance
Voltage supply	+12V DC
Cut-off voltage	9V
Charging current	2A
Fully charged voltage	12.6V
Physical dimension	98.5mm×68.5mm×26mm
Maximum instantaneous discharge current	13A
Maximum continuous discharge current	6A
Weight	268g
Battery protection	Short-circuit, over-current, over-charging, over-discharging protection, support for charging while using, built-in safety valve

Table 3: Performance of the power supply

## Depth Camera / 3D camera imaging principle

Different from regular 2D camera, 3D cameras are also called as depth camera, it can detect the depth of field in the shooting space using its camera and later processing, and thus we can get the distance from every spot in the vision to our camera installed on the car. Together with the (x,y) coordinates in the 2D images, the 3D spatial coordinates of each point in the image can be obtained. Then the 3D coordinates can be used to restore the real scene and realize applications such as scene modeling.

As shown in figure 9, The principle of depth camera is basically developed from our binocular vision, and is mainly due to the parallax. When the human eye looks at any object, there are two angles of view because there is a certain distance of about 5cm between the two eyes in space. This results in the left and right eyes not seeing exactly the same image, which is called parallax. This subtle parallax is transmitted to the brain through the retina, which shows the front and back of the object, producing a strong sense of three-dimensional. And so, the origin idea of depth camera is to use two normal cameras at a certain distance to acquire 3D data by simulating the human eye. The parameter of depth camera is shown in table 4.

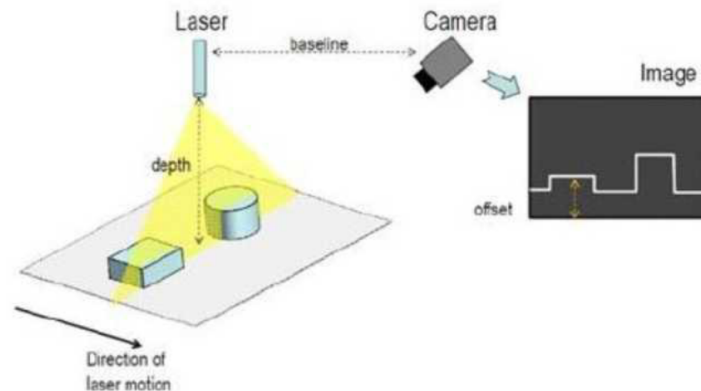

Figure 9: 3D Camera

## Micro-controller: STM32F407VET6

We use STM32F407VET6 as our micro-controller which based on the high-performance ARM® Cortex™-M4 32-bit RISC core operating at a frequency of up to 168 MHz. The Cortex-M4 core features a Floating point unit (FPU) single precision which supports all ARM single-precision data-processing instructions and data types. It also implements a full set of DSP instructions and a memory protection unit (MPU) which enhances application security.

The STM32F407VET6 also incorporates high speed embedded memories, (Flash memory up to 1 Mbyte, up to 192 Kbytes of SRAM), up to 4 Kbytes of backup SRAM, and an extensive range of enhanced I/Os and peripherals connected to two APB buses, three AHB buses and a 32-bit multi-AHB bus matrix.

All devices offer three 12-bit ADCs, two DACs, a low-power RTC, twelve general-purpose

16-bit timers including two PWM timers for motor control, two general-purpose 32-bit timers, a true random number generator (RNG). They also feature standard and advanced communication interfaces.

New advanced peripherals include an SDIO, an enhanced flexible static memory control (FSMC) interface (for devices offered in packages of 100 pins and more), a camera interface for CMOS sensors.

The working voltage of STM32F407VET6 is from 1.8V to 3.6V and also offers with devices in various packages ranging from 64 pins to 176 pins. The set of included peripherals changes with the device chosen.

The schematic of STM32F407VET6 is in the figure below and we can see that, the pins of it is connected to many modules like Bluetooth module interface, handle module interface, CAN interface, motor driver circuit, etc. These functions are what we plan to implement later with different chips and devices, and they all connects and are controlled through the STM32F407VET6.

STM32F407VET6 Main Control Board will be powered by a 12V 0-3A 5600mAh Lithium Battery through a 12V regulator. The overall layout and connection to other components are shown in figure 11 and table 5. The connection between motors and main control board is shown in figure 12 and figure 13.

### Motor Driver

For the motor driver of the car, we use a DC brush motor driver AT8236 to control. The motor can be controlled in both directions with peak currents up to 6A. Using the current attenuation mode, the motor speed can be controlled by pulse width modulation (PWM) of the input signal with a low power sleep mode. The AT8236 integrates synchronous rectification to significantly reduce system power requirements. Internal protections include over-current, short-circuit, under-voltage lockout, and over-temperature protection, and the AT8236N provides a fault-detect output pin. The AT8236 is available in an ESOP8 package with exposed pads for improved heat dissipation, and it is a lead-free product that meets environmental standards.

The working characteristics are as follows. It is a Single Channel H-Bridge Motor Driver, with a wide voltage supply from 5.5V to 36V. It has a low RDS(ON) resistor, which is 200m (HS+LS). The peak drive output can reach 6A, and the continuous output is 4A. Also, it is equipped with a PWM control interface and supports low-power sleep mode.

In the below figure 14 is the pin assignment of the AT8236.

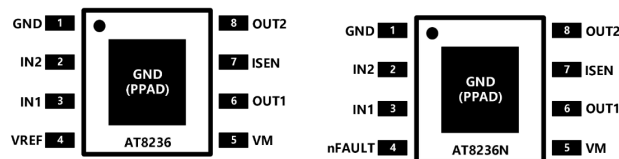

Figure 10: AT8236

## Raspberry Pi 4 Model B

As we can see on the figure above, the Raspberry Pi 4 Model B we used is a portable small “computer” that use SD cards as hard disks. This product’s key features include a high-performance 64-bit quad-core processor, dual-display support at resolutions up to 4K via a pair of micro-HDMI ports, hardware video decode at up to 4Kp60, up to 4GB of RAM, dual-band 2.4/5.0 GHz wireless LAN, Bluetooth 5.0, Gigabit Ethernet, USB 3.0, and PoE capability (via a separate PoE HAT add-on), which can definitely meet our design needs.

The dual-band wireless LAN and Bluetooth have modular compliance certification, allowing the board to be designed into end products with significantly reduced compliance testing, improving both cost and time to market.

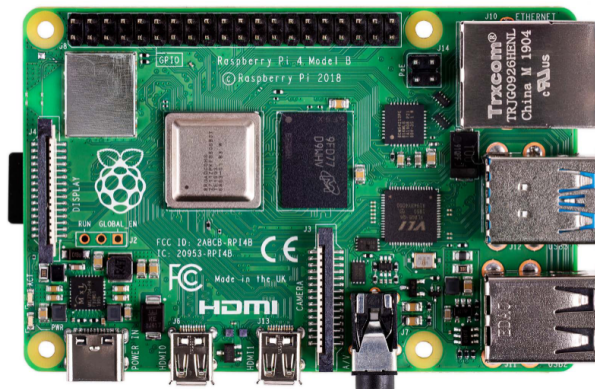

Figure 11: Raspberry Pi 4 Model B

## 2.3 Subsystem Verifications

### 2.3.1 Remote System

Requirements and Verification Table of Remote system

Requirements	Verification
The mobile phone uses Bluetooth to communicate with the car module.	<ol style="list-style-type: none"><li>1. Test whether the mobile phone can accurately receive the specified content of the trolley, and record the communication delay, repeat many times to ensure the stability of the communication, the stability of the communication should be greater than 95% of the distance from the farthest point in the scene.</li><li>2. Expand the distance between the car and the mobile phone until the car can't receive the information stably, record the limit communication distance between the car and the mobile phone, the limit communication distance of the car should be greater than 1.5 times of the distance between the farthest points in the scene.</li></ol>
Express pickup range is large	<ol style="list-style-type: none"><li>1. Considering that the recognition range of RFID is 0-4m, it can only do the recognition in short distance. We use grouping to find items.</li><li>2. The same as the courier station, we number the shelves themselves and use the visual recognition of the depth camera to find the location of the shelves first.</li><li>3. After arriving at the location of the designated shelves, we use the RFID reading module to read the location of the specific goods.</li></ol>

### 2.3.2 Grab System

**Requirements and Verification Table of Grab system**

Requirements	Verification
Every segment of the manipulator can reach up to 270° without any load and under a 12V power supply	<ol style="list-style-type: none"><li>1. Record the initial position of the segment.</li><li>2. Connect the servo of the segment to the +12V power supply.</li><li>3. Record the final position of the segment until the segment can not move in a certain place.</li><li>4. Measure the angle between the initial and final position of the segment.</li></ol>
Grasp objects ranging from 2 to 10 cm in diameter with the weight ranging from 200g to 300g.	<ol style="list-style-type: none"><li>1. Prepare a set of objects ranging from 2 to 10 cm in diameter with varying surfaces and varying weight from 200g to 300g.</li><li>2. Program the robotic arm to attempt to grasp each object using its standard operating procedure.</li><li>3. Record whether each grasp is successful (object is securely held) and note any damage to the objects.</li></ol>



### 2.3.3 Car System

**Requirements and Verification Table of Car system**

Requirements	Verification
Visual recognition requires the depth camera to shoot with sufficient clarity during operation	<ol style="list-style-type: none"> <li>1. Stabilise the support frame of the depth camera and change the position of the depth camera if necessary to reduce shaking during operation.</li> <li>2. Let the trolley run at the rated speed and use the visual recognition algorithm to recognise the objects captured by the camera to ensure that the recognition accuracy reaches more than 95%.</li> <li>3. Test the trolley steering, the movement of the robot arm will not affect the recognition range of the camera.</li> </ol>
The trolley can run at the rated speed after loading.	<ol style="list-style-type: none"> <li>1. Test the trolley in the case of not grasping any object can be normal driving turn, the speed of 0.3m / s or more</li> <li>2. Test whether the trolley can run normally after grasping the rated kinds of objects with the speed above 0.3/s. Use a multimeter to measure the operation of the motor, check whether there is no idling and other conditions that can lead to motor burnout.</li> </ol>
The trolley will not turn over in the process of grasping objects while driving	<ol style="list-style-type: none"> <li>1. Keep increasing the weight of the goods, test the grasping process of the trolley until the trolley appears to be tipped over, record the grasping limit value of the trolley.</li> <li>2. Increase the counterweight of the trolley appropriately to balance the travelling pressure of the trolley and the weight of the gripped goods.</li> </ol>

## 2.4 Tolerance Analysis

### 2.4.1 Endurance Calculation

Considering the capacity of the battery, we need to calculate whether the lithium battery supports the car to complete the farthest gripping task. Furthermore, we need to calculate how many grabbing tasks the car can complete. To meet practical work needs. Here is our calculation.

- Battery capacity: 5600mAh (but we assume 80% of it can be used)
- Working power (both car and robot arm): 15W
- Working voltage and current (both car and robot arm): 5V, 3A
- Assumed one time fetching distance: 5m to the shelf and back, 10m in total
- Moving velocity: 0.3m/s
- Ignore the RFID tolerance because RFID can last 30 days and won't be a bottleneck.
- Ignore the standby and fetching time by using 80% of the battery capacity.
- Ignore the effect of the weight of goods on the working power because they're small.

So, the calculated time the car can work without the standby time is:

$$\frac{(5.6 \times 3600A \cdot s) \times 80\% \cdot (5V)}{15W} = 5376 s = 89.6 min$$

And the number of times the cart can pick up the goods is:

$$\frac{5376 s \times 0.3m/s}{10m} = 161 times$$

Therefore, the selection of power supplies and components now meets our requirements.

### 2.4.2 Grab Simulation

In the course of evaluating the operational efficiency and safety of the system, a critical factor to take into account is the potential risk of the small vehicle toppling over due to the load of the items being manipulated throughout its movement. This concern arises from the dynamics involved when the robotic arm engages in the act of grasping objects and subsequently relocating them. To rigorously assess this risk, we have engaged in a comprehensive process involving both the creation of theoretical models and the execution of practical tests aimed at understanding the behavior of the system under various conditions.

Our analysis specifically focused on the capability of the robotic arm to maintain the stability of the small vehicle by adeptly managing its center of gravity. This involves a sophisticated mechanism where the arm adjusts its positioning and orientation in real-time,

ensuring that the center of gravity remains within the operational base of the vehicle, thus mitigating the risk of a rollover incident. Through this methodical approach, encompassing both simulation and empirical testing, we have gathered compelling evidence to support the conclusion that the system possesses robust mechanisms for stabilizing itself during operations. Consequently, based on the data and insights derived from our modeling and testing phases, we are confident in asserting that the likelihood of the vehicle experiencing a rollover due to the weight distribution challenges posed by the cargo handling process is negligible. This finding underscores the effectiveness of the design considerations implemented in the robotic arm's control algorithms, specifically tailored to ensure operational safety and reliability in real-world scenarios.

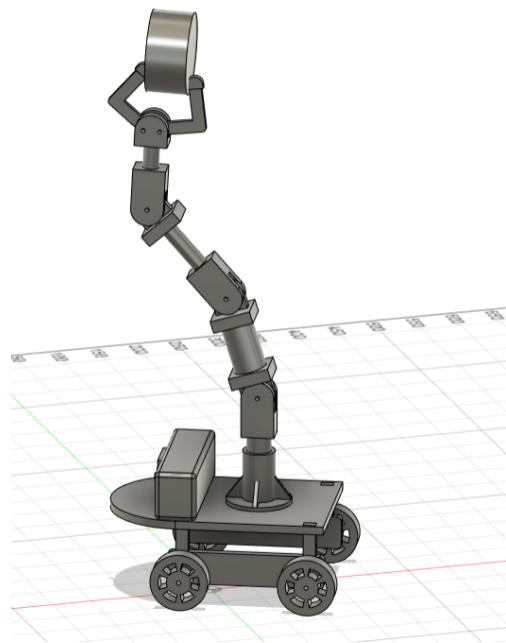

Figure 12: Car Model

### 2.4.3 Velocity Analysis

Since the motor can supply the torque of 4.5kg-cm, with the power of 4W, according to the ideal relationship between the rotational speed and torque of the motor:

$$P = \tau\omega$$

Where,

$\tau$  = The torque of the motor

$P$  = The power of the motor

$\omega$  = The angular velocity of the motor

At this time, we can get our minimal angular velocity:

$$\omega = 9.061 \text{ rad/s}$$

With the diameter of the wheel, we can get the linear velocity at this time in the ideal case ignoring any load and weight:

$$v = 3.442 \text{ m/s}$$

Since the total weight of our car is 4.5kg and the friction factor of the ground is 0.4 0.6, and based on the relationship between the power and force:

$$P = Fv$$

With 4 wheels, at each wheel we can estimate the traction needed:

$$4.4145N \leq F \leq 6.62175N$$

So, the velocity at each wheel:

$$0.604 \text{ m/s} \leq v \leq 0.906 \text{ m/s}$$

Since the minimum velocity of the car we set is 0.3m/s, we can estimate the weight of the good on our car:

$$2.737kg \leq m \leq 3.636kg$$

By applying the maximum weight of the good on segment of our manipulator, we can get the FEA result as shown below (figure 17 and 18):

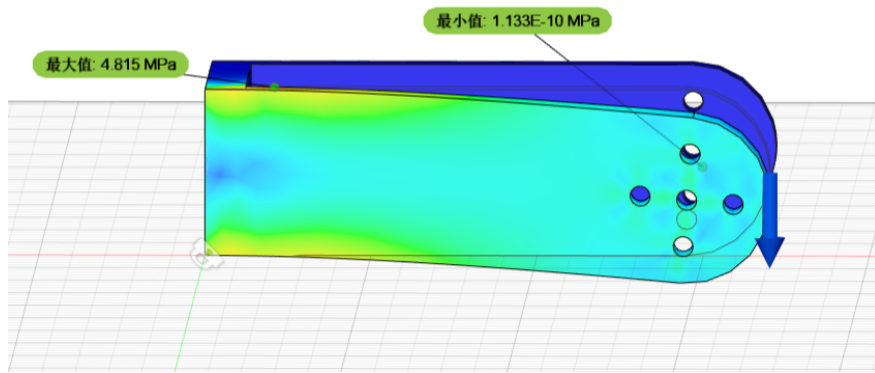

Figure 13: FEA result of the segment

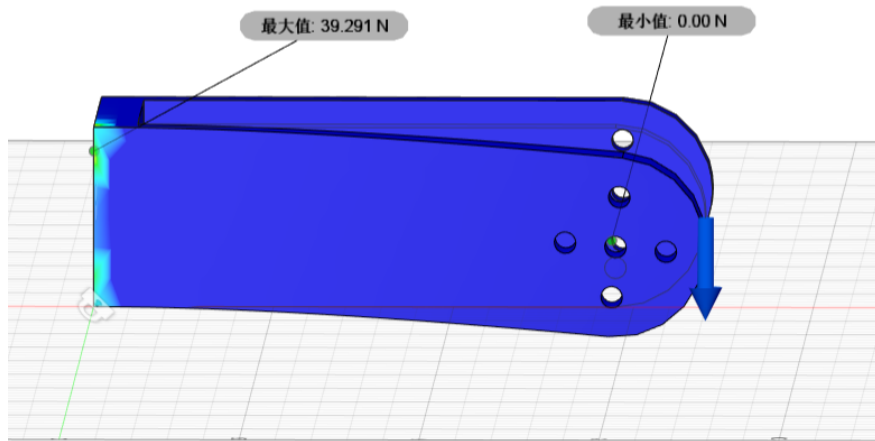

Figure 14: FEA result of the segment

With the maximum stress 4.815MPa and maximum reaction force 39.291N, which provides the safety factor of 15.

### 3 Cost & Schedule

#### 3.1 Cost

Include a cost analysis of the project by following the outline below. Include a list of any non-standard parts, lab equipment, shop services, etc., which will be needed with an estimated cost for each.

- Labor: (For each partner in the project)
- Assume a reasonable salary (\$/hour) x 2.5 x hours to complete = TOTAL

Then total labor for all partners. It's a good idea to do some research into what a graduate from ECE at Illinois might typically make.

- Parts: Include a table listing all parts (description, manufacturer, part , quantity and cost) and quoted machine shop labor hours that will be needed to complete the project.
- Sum of costs into a grand total

##### 3.1.1 Labor

According to the table 6 The following are the labor costs calculated based on the actual workload of our projects and the course hours required after taking into account the hourly rates of senior design projects and UIUC internships in previous years.

Partner	Hourly Salary	Working Hours	Total
Zhixin Chen	\$35	200	$\$35 * 200 * 2.5 = \$17500$
Zhuozheng He	\$35	200	$\$35 * 200 * 2.5 = \$17500$
Xinyue Lu	\$35	200	$\$35 * 200 * 2.5 = \$17500$
Size Feng	\$35	200	$\$35 * 200 * 2.5 = \$17500$
Sum			\$70000

Table 4: Labor Cost

##### 3.1.2 Parts

The estimated parts cost is listed in Parts Cost Analysis table. The estimated cost is about \$650.

Description	Manufacturer	Vendor	Quantity	Cost/Unit	Total Cost
12V 0-3A 5600mAh Lithium Battery	Wheeltec	Taobao	3	17.53	52.59
5V Regulator	Self Design PCB	J@LC	2	10	20
RFID Read and Write Module	FK	Taobao	1	53.27	53.27
RFID Labels	FK	Taobao	20	0.087	1.74
STM32F407VET6 Main Control Board	Wheeltec	Taobao	1	63.7	63.7
Raspberry Pi 4B(CPU GPU/NPU 64G MicroSD)	Wheeltec	Taobao	1	129.67	129.67
Astra RGBD Camera	Wheeltec	Taobao	1	138.1	138.1
6 joint robotics arms	Wheeltec	Taobao	1	98.3	98.3
Car Board	Wheeltec	Taobao	1	26.8	26.8
MG513 Motors	Wheeltec	Taobao	4	11.2	44.8
Shelves	JD	JD	2	7.78	15.56
Loads	JD	JD	20	0.035	0.7
Total					644.33

Table 5: Parts Cost Analysis

### 3.1.3 Total Cost

The Total cost of labor and parts is  $\$70000 + \$644.33 = \$70644.33$

## 3.2 Schedule

The weekly schedule is listed in the table 8 below.

Week	Zhixin Chen	Zhuozheng He	Xinyue Lu	Size Feng
3/25-3/31	Check components ports	Combine car and robotic arm	Check the power system	Check the robotic arm
4/1-4/7	PCB Board Design and Test	Robotic arm coding	RFID coding	Tracking coding
4/8-4/14	Test Power Subsystem (regulator)	Test the robotic arm moving and grabbing	RFID test	Test the camera
4/15-4/21	Test the system of tracking with camera	Test the grab subsystem in the environment	App coding	Finish the robotic arm control while grabbing
4/22-4/28	Test subsystem and debug	Test subsystem and Debug	Test subsystem and Debug	Test subsystem and Debug
4/29-5/5	Integrate, finalize decoration	Integrate all	Integrate all	Integrate all
5/6-5/12	Mock Demo	Mock Demo	Mock Demo	Mock Demo
5/13-5/19	Prepare for Final	Prepare for Demo	Prepare for Demo	Prepare for Demo
5/20-5/26	Individual Report	Individual Report	Individual Report	Individual Report

Table 6: Weekly Schedule



## 4 Conclusion

### 4.1 Accomplishments

Our innovative project designed and realized an Autonomous Robot Transport Car that combined a smart car and robot arm that can plan and perform their function on their own after learning the environment first to form a map and then given the designated goods to fetch.

Specifically, the material of our car is easily feasible based on the technology of the Raspberry control board and STM32 chips, and the 3D printing technology to build the trays to carry the goods. For the users, we've also got a phone app to remotely give command to the car and control it. Then the command will be processed by the chips on the car in which we implemented some algorithms to do the rest of the moving and recognizing the road, shelves, and the goods.

Because the environment where the car is used can be large than the scope of identification of the RFid reader that we use to store and acquire the exact position of the goods, we first let the car study the map and move close to the shelves, and then, Although each components have their own different control logics, we manage to let them communicate considering their different serial port protocols.

### 4.2 Uncertainties

Despite the remarkable achievements of our final design, it is important to acknowledge the presence of certain uncertainties that may impact the overall performance of the system.

First, as we use a RGB camera installed on the robot arm so that when the car approaches the shelves, it can use it to detect the goods we wanted. But it can be uncertain that whether it can correctly recognize the goods and send back the picture. Also, when the robot needs to grab things out of the basket on the side of the car, it may fail to recognize the goods in the basket, too, since when the robot arm bends, there may not be enough vision area for the camera to detect. To address this, we make our goods uniform in their shape and try distinctive colors on them and minimize the impact.

Another possible uncertainty may come from the instability of Blue Tooth and Wi-Fi connection, a weak signal can impact the transmission latency, it can lead to potential disruptions and delays to the transmission of data.

### 4.3 Future Work

We are currently only able to support gripping small sized items and transporting them to a predetermined location. In practice, in industry, transportation carts should need to be able to grip goods of all sizes, as well as have a much larger number of shelves to judge. Therefore, we believe that in future work, the first thing we need to do is to replace the gripper arms with suction cups, so that they can be adapted to different sizes

of goods. Second, we need to optimize the algorithms for route planning so that they can be adapted to larger scenarios.

Other directions that can be optimized are to build a cluster of transport trolleys, where multiple trolleys are needed to improve the efficiency of picking up goods in real application environments. The efficiency of picking up goods can be improved by optimizing the clustering algorithm. Because RFID also has the function of writing labels, in addition to the pickup function can also be added to the inventory function, to provide more convenience to the courier station staff.

## **4.4 Ethics Considerations**

### **4.4.1 Ethics**

1. There may be overpowering and burning out parts due to the inappropriate choice of car motor, so we should consider the suitable working power and speed of our car motor and then make the purchase.
2. There may be short circuit when connecting the driving circuit or the recognizing circuit, so we should design short-circuit protection circuits and regularly check and document progress.
3. If the ideal results of the experiments are hard to get, we should make sure that there's no plagiarism or fake and made up figures of the results, according to the IEEE code of ethics, "to seek, accept, and offer honest criticism of technical work, to acknowledge and correct errors, to be honest and realistic in stating claims or estimates based on available data, and to credit properly the contributions of others." [1]

### **4.4.2 Safety**

1. If the car is upgrade to a bigger size and doesn't build a safe environment when using it in the factory to fetch large cargo, the car may run into people and cause injury. So safety fence can be erected around the shelf and the machine's path for movement.
2. When the machine malfunctions, people who are using it should give feedback in a timely manner and seek repairs.
3. People who operates the machine should be trained according to the IEEE code of ethics, "to maintain and improve our technical competence and to undertake technological tasks for others only if qualified by training or experience, or after full disclosure of pertinent limitations." [1]

## References

- [1] IEEE. "IEEE Code of Ethics." (2016), [Online]. Available: <https://www.ieee.org/about/corporate/governance/p7-8.html> (visited on 02/08/2020).