

ECE 445
SENIOR DESIGN LABORATORY
DESIGN DOCUMENT

Smart Power Routing

Team #2

YUNFEI LYU (yunfeil3@illinois.edu)
JINGJING QIU (jqiu12@illinois.edu)
JIABAO SHEN (jiabaos3@illinois.edu)
XIAOYI HAN (xiaoyih2@illinois.edu)

TA: Ningfang Liu

Wednesday 27th March, 2024

Contents

1	Introduction	1
1.1	Problem	1
1.2	Solution	1
1.3	Visual Aid	2
1.4	High-level Requirements List	2
2	Design	4
2.1	Block Diagram	4
2.2	Physical Diagram	4
2.3	Subsystem Overview	5
2.3.1	User Interface Subsystem	5
2.3.2	Power Subsystem	5
2.3.3	Control Subsystem	8
2.3.3.1	Overview	8
2.3.3.2	Load	10
2.3.3.3	Charge	12
2.3.3.4	Requirement and Verification	13
2.3.4	Display Subsystem	13
2.3.4.1	HD44780 LCD	14
2.3.4.2	Power Monitoring and Display in Monitor	17
2.3.4.3	Requirement and Verification	20
2.4	Tolerance Analysis	20
3	Cost and Schedule	25
3.1	Cost Analysis	25
3.2	Schedule	26
4	Ethics and Safety	28
4.1	Ethics	28
4.2	Safety	28
	References	30

1 Introduction

1.1 Problem

In the evolving landscape of energy management, the “Smart Power Routing” project confronts not only the challenge of efficiently distributing and utilizing power among diverse devices but also the critical issue of maintaining stability in the power supply. Traditional energy systems exhibit significant shortcomings when faced with the dynamic nature of modern electrical demands, particularly in scenarios requiring the seamless operation of devices with varying energy needs. These systems often falter in dynamically managing power supply, leading to not just energy waste and inconsistent device functionality, but also to fluctuations that can compromise the stability of the entire power grid.

The stability of power supply is paramount, especially as we integrate more renewable energy sources and adopt more sophisticated electrical devices. The inherent variability in power generation from sources like wind and solar, coupled with the unpredictable nature of user interactions—such as switching devices on/off, plugging/unplugging, or even manually generating power introduces a level of complexity that traditional systems are ill-equipped to handle. This can result in voltage sags or surges that not only affect the performance and lifespan of household and industrial devices but also pose a broader risk to the integrity of electrical infrastructure. Our solution is a dynamic power management system that intelligently adapts voltage supply in real-time, responding to user interactions like switching devices or manual power generation.

This project aims to demonstrate the practicality of smart power management in real-world scenarios, offering an accessible and engaging illustration of these principles for a broad audience [1]. STEM education has become a strategic choice for education reform in countries around the world because it helps develop students with key abilities to adapt to the future and have the potential to play a role in future life and work [2]. In the realm of STEM education, fostering an early interest and understanding of electrical circuits is crucial. Electrical circuits serve as the backbone of modern technology, and comprehension of their principles lays the foundation for future innovations. Investing to ensure a pipeline of workers skilled in STEM competencies is a workforce issue, an economic-development issue, and a business imperative [3]. We hope this project would be educational as well as enjoyable to children in kindergarten and primary school by showing a simplified version of smart power system about how power is distributed and controlled in our daily life.

1.2 Solution

Our smart routing system manages and stores energy from electrical outlets and manual inputs — including hand-crank generators and a pneumatic turbine — into a battery. After receiving power information from the sensor, it then dynamically allocates power to a fan and light bulb in response to user interactions. The system’s adaptability is managed by a microcontroller, which ensures efficient energy distribution and maintains device operation through variable conditions.

In greater detail, our smart routing system merges power harvested from electrical sockets with manually generated energy, utilizing hand-crank generators and a pneumatic turbine squeezed air pump—to efficiently convert mechanical energy into electrical power. The power is transferred to the electrical appliance and the excessive power is stored in a battery to ensure a stable supply. We also have an intuitive user interface, comprising switches and buttons that allow users to easily control the system, toggling the state of the socket, light, and fan, or activating the manual generators as needed. The operational demands of the fan and lightbulb are monitored by current sensors, which relay information on power consumption fluctuations to the microcontroller. This central processing unit, acting as the system’s brain, analyzes the input from sensors and user interactions to dynamically adjust power distribution and output commands to transistor-based circuits, ensuring that energy supply meets demand in real time and maintains uninterrupted device operation. Complementing this, an LED screen offers users a clear visual representation of the battery’s storage levels and the real-time power usage of both the fan and lightbulb, highlighting the system’s operational efficiency and the intricate power dynamics between the energy sources and the devices powered.

1.3 Visual Aid

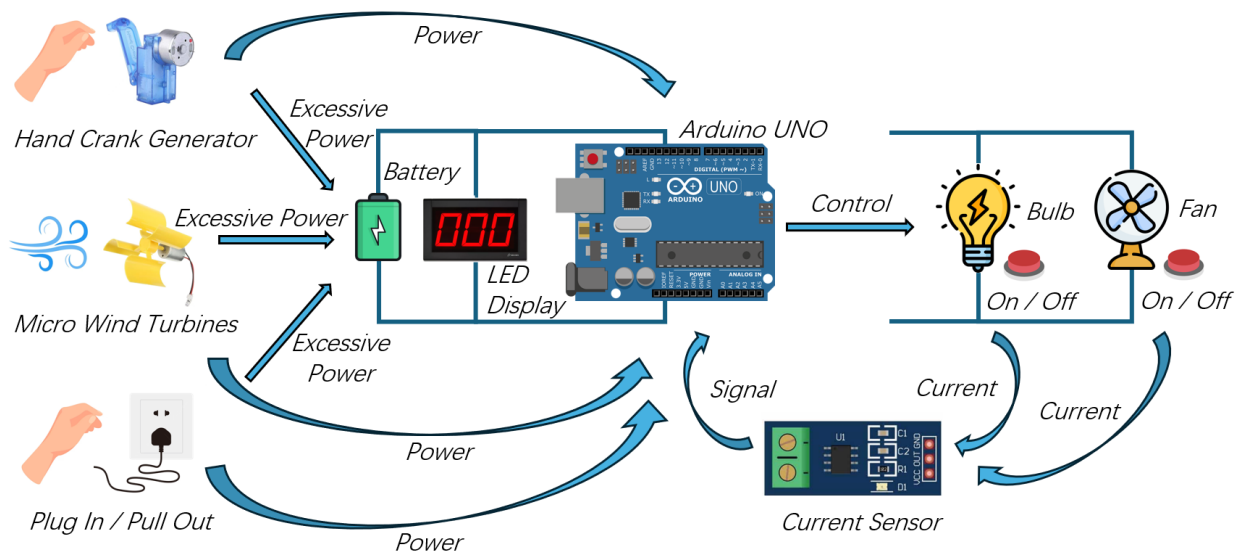

Figure 1: Visual Aid of Smart Power Routing

1.4 High-level Requirements List

- **Reliability:** The system should consistently maintain power levels within a $\pm 1\%$ fluctuation range to both the fan and the lightbulb regardless of user interactions, such as turning switches on and off and the presence of manual power generation from hand cranks or turbine inputs.

- **Efficiency:** It should maximize the energy harvested from manual inputs, targeting a minimum energy conversion and distribution efficiency of 90%.
- **Good Visualization:** The project should successfully demonstrate the principles of smart power routing in a way that is understandable and engaging for viewers, with clear displays of current power and battery condition.

2 Design

2.1 Block Diagram

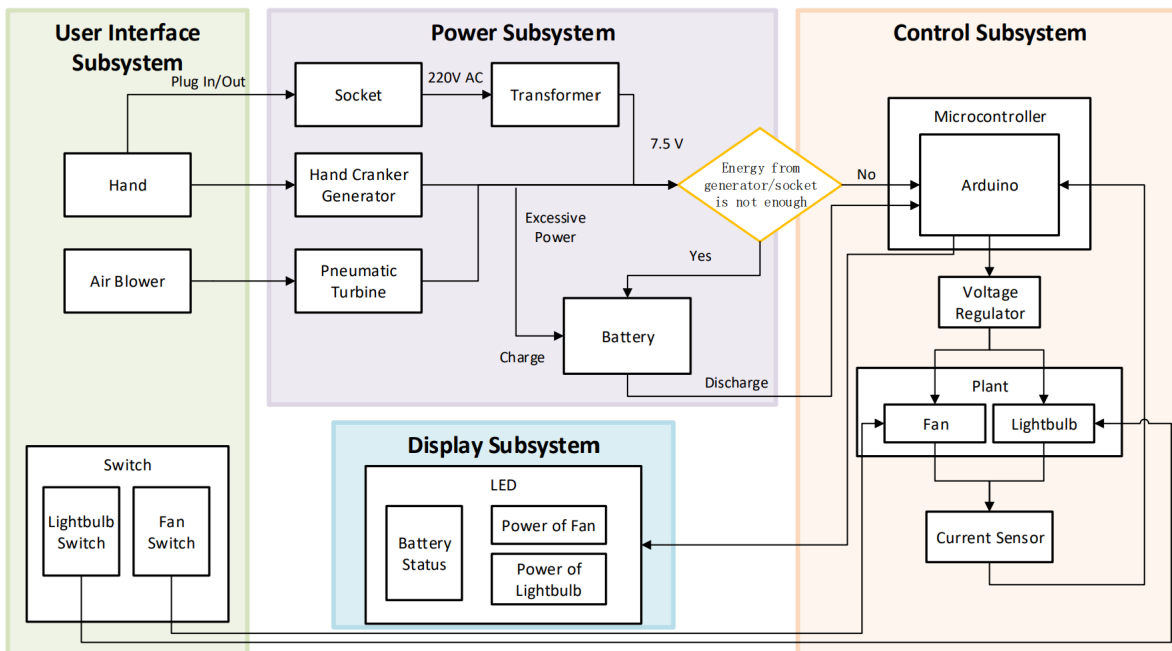

Figure 2: Block Diagram of Smart Power Routing

2.2 Physical Diagram

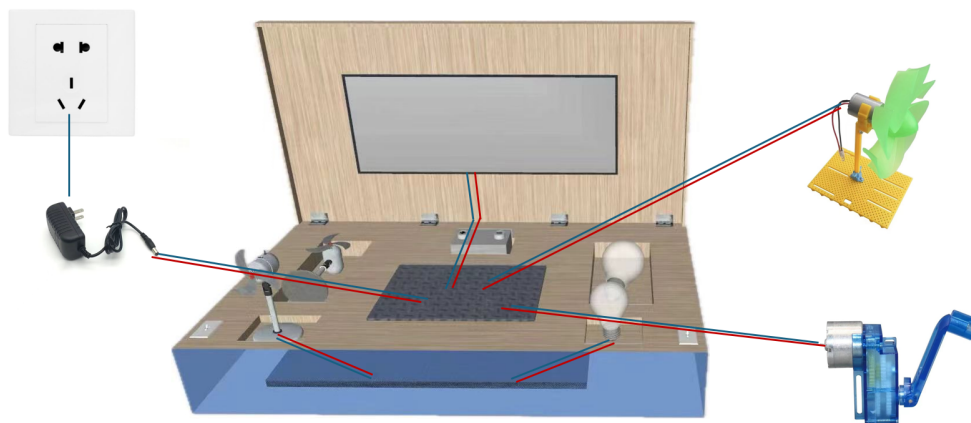

Figure 3: Physical Design

2.3 Subsystem Overview

2.3.1 User Interface Subsystem

The User Interface Subsystem acts as the interactive interface between the user and the system, including a socket, a hand crank generator and a pneumatic turbine. The user can choose to plug in/out the socket, pump the hand crank generator, or blow wind into the turbine to provide external power for the system. As shown in Fig.4, Fig.5 and Fig.6. There are also two switches for users to turn a light bulb and fan on and off respectively.



Figure 4: Hand Crank Generator

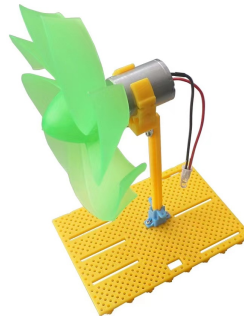

Figure 5: Pneumatic Turbine



Figure 6: 220 V AC - 7.5 V DC Power Adapter

The system is designed to allow users to dynamically interact with the power supply choice and load options of the whole system. The requirements and verification can be found in Table 2.3.1.

2.3.2 Power Subsystem

The Power Subsystem plays a critical role in providing and managing electrical power within the system. It is engineered to convert voltage from a 220 V AC source to 7.5 V DC using a transformer, and is adept at accommodating power inputs from a hand crank generator and a pneumatic turbine. There is also a battery designed to store excess electricity, ensuring a reliable power supply even when the input from conventional sources falls short.

The subsystem employs seven relay modules to receive digital signals from Arduino-Uno of the control system to control the switching of the three charging branch-circuits and the four power loading sub-system. The mini-SSR-relay module for PCB is in Fig.7 and Fig.8. These modules are integral for circuit switching, automatic adjustment, and ensuring safety protections are in place.

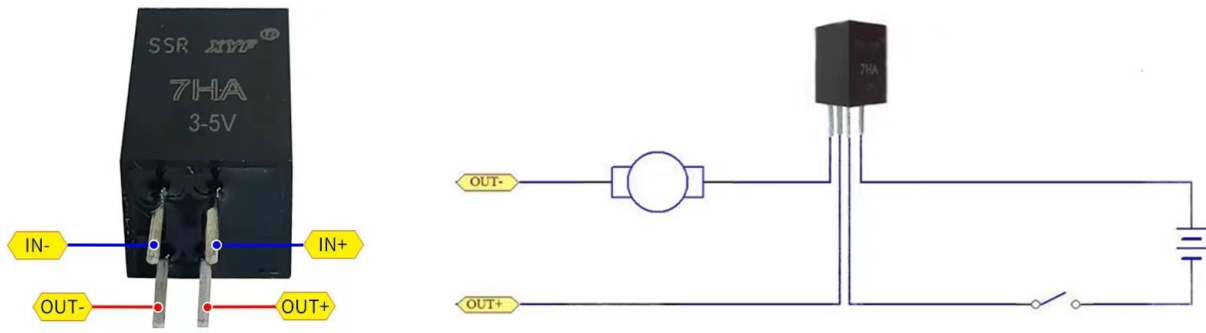

Figure 7: Relay Module and its Wiring Diagram

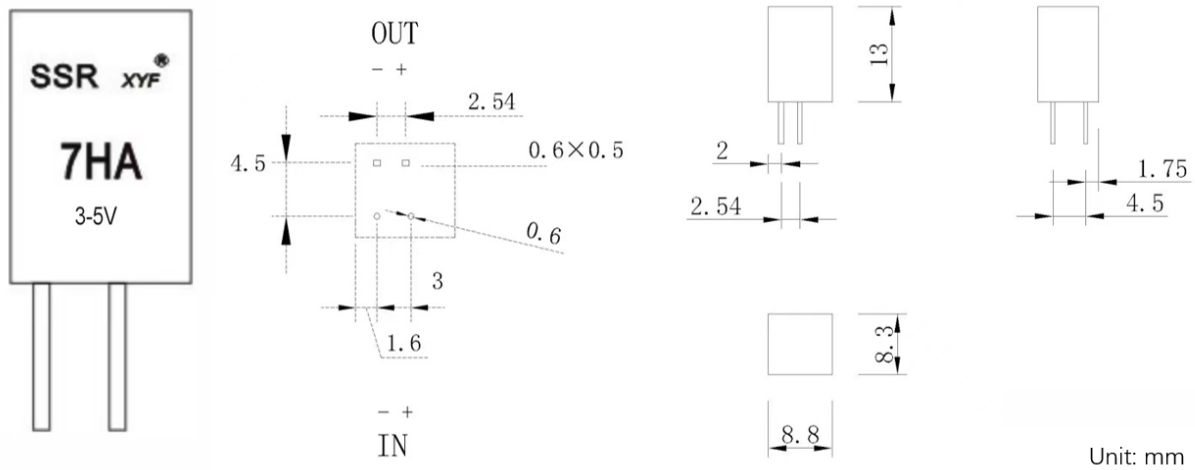

Figure 8: Relay Module Size and its Pin Size

As different power source candidates including socket, hand generator, wind turbine and battery have different voltage values. What's more, sources like hand generator and wind turbine can fluctuate significantly over time, we connect these power sources to a switching regulator shown in Fig.9 and Fig.10 which is utilized for providing stable voltage conversion to precisely meet the voltage requirements our loads consisting of a lightbulb and a fan.

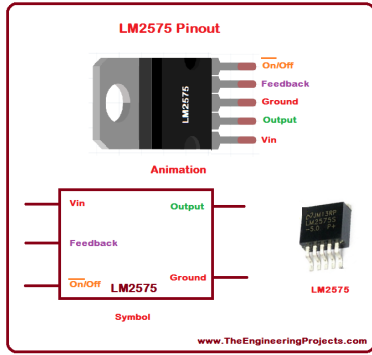

Figure 9: LM2575 Switching Regulator and Pins

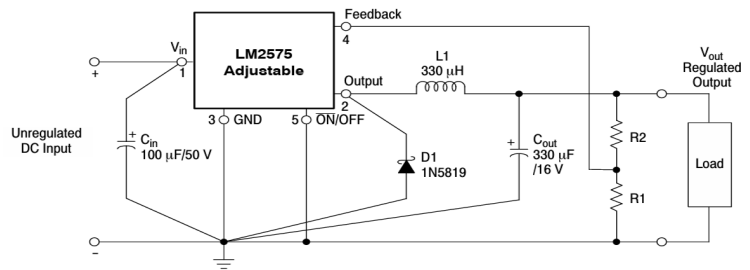

Figure 10: Switching Regulator Typical Test Circuit

The overall power system circuit is shown in Fig.11.

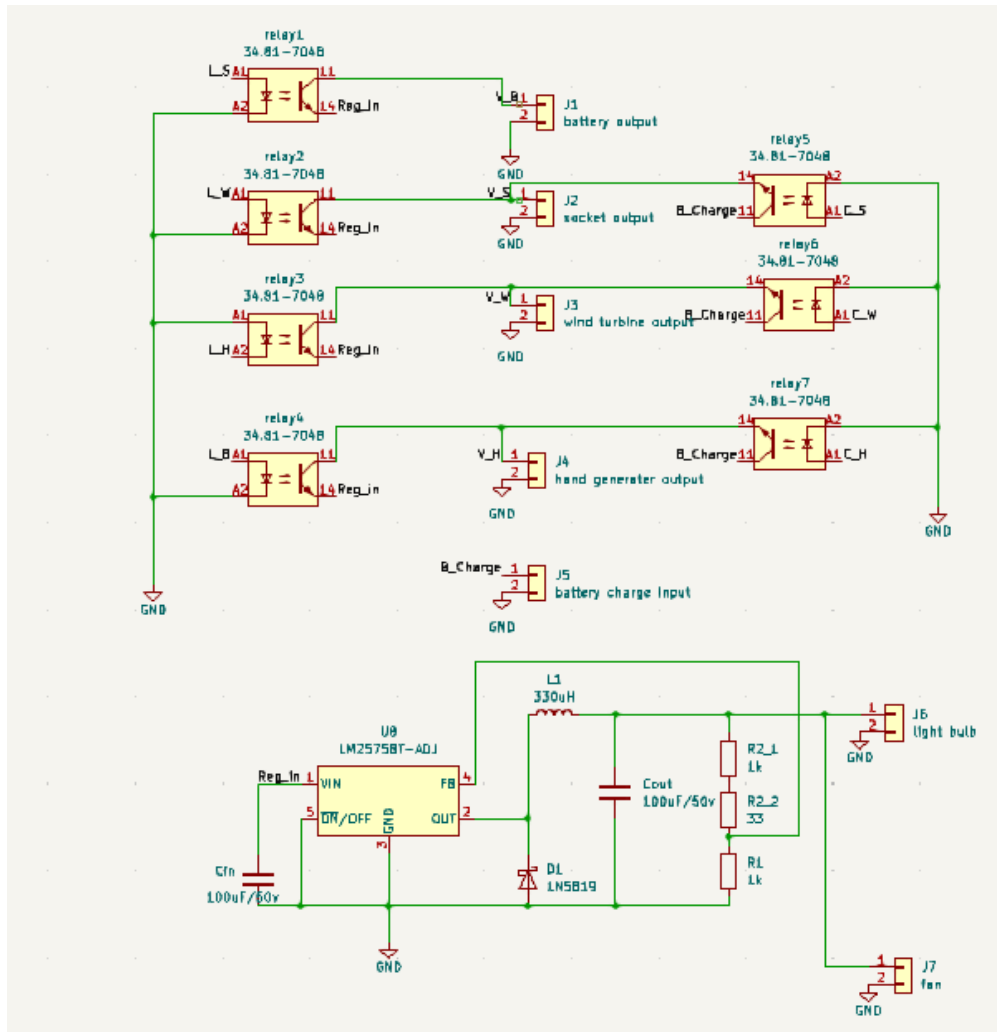

Figure 11: Power System Circuit

The requirements and verification of this subsystem can be found in Table 4.

2.3.3 Control Subsystem

2.3.3.1 Overview

In the Control Subsystem, the Arduino microcontroller plays a core role in receiving input signals from the User Interface Subsystem and the current sensor, sending control digital signals to the Power Subsystem and output processing result to the Display Power subsystem. Arduino has found extensive applications in control systems due to its versatility, affordability, and accessibility. With its powerful microcontroller, Arduino can perform real-time processing of sensor data and execute control algorithms efficiently.

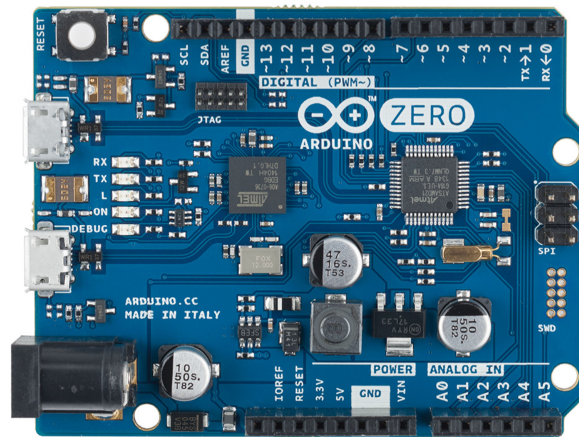

Figure 12: Arduino UNO3

The control subsystem is divided in to two parts: one is controlling which power source to the load, the other is controlling which power source to charge the battery. There are 4 inputs, 8 outputs and 2 parameters in the control part of Arduino.

Signal	Symbol	Pin
Voltage of Socket 5 V	V_S	A0
Voltage of Wind Turbine	V_W	A1
Voltage of Hand-cranker Generator	V_H	A2
Voltage of Battery	V_B	A3

Table 5: Arduino Control Inputs

Signal	Symbol	Pin
Socket to Load	L_S	3
Wind Turbine to Load	L_W	5
Hand-cranker Generator to Load	L_H	6
Battery to Load	L_B	7
Socket to Charge	C_S	9
Wind Turbine to Charge	C_W	10
Hand-cranker Generator to Charge	C_H	11
Connect to Display Subsystem	LCD	2

Table 6: Arduino Control Outputs

Signal	Symbol	Value
Minimum Voltage of Regulator	VL_min	5 v
Minimum Voltage of Charging Chip	VC_min	7 v

Table 7: Arduino Control Parameters

The circuit diagram for the Arduino control system is shown in Fig.13.

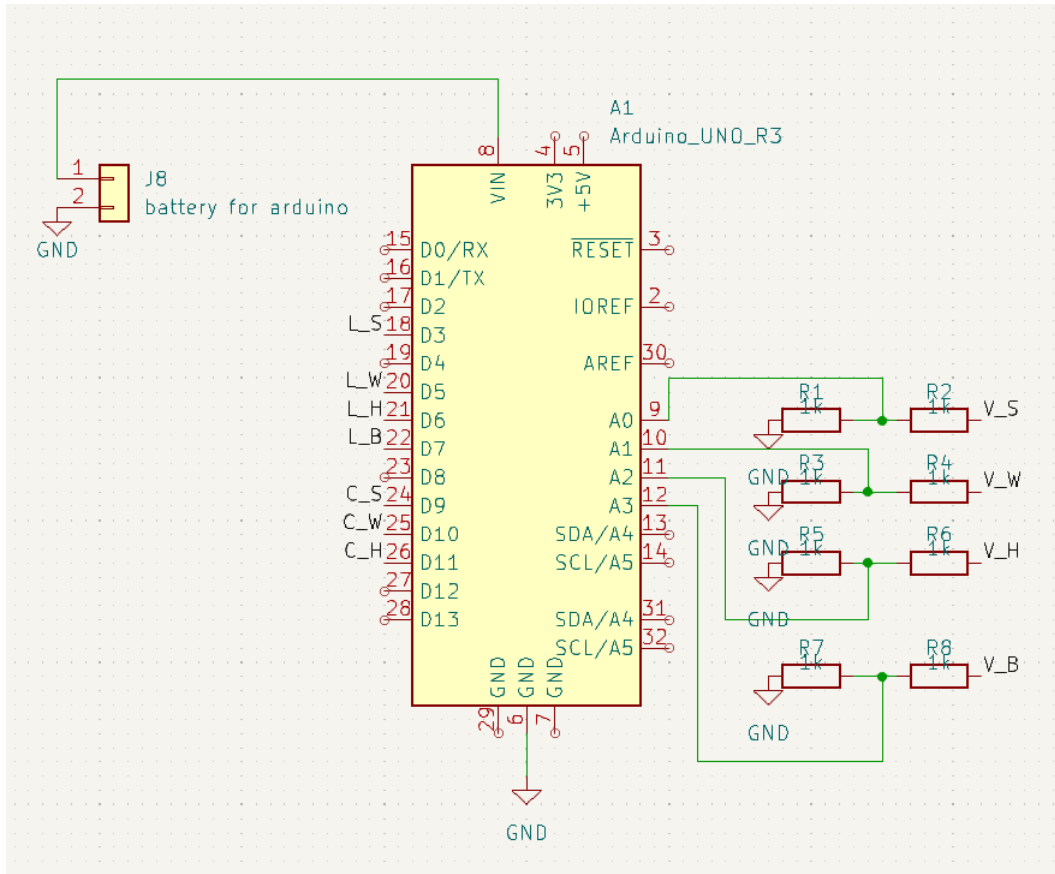

Figure 13: Control Subsystem Circuit

2.3.3.2 Load

The Arduino receives analog inputs from the battery and three power sources: 5 V DC from socket, Wind Turbine and Hand-cranker Generator and provides digital signals to the relays to control which one to provide power to the loads and whether to show charging reminder on LCD.

Three power supplies are prioritized for selection, with battery power being utilized only when none of the three can deliver sufficient power. Considering the stability of the three power sources, the priority order for selecting a power source is as follows: socket, wind turbine, and hand-cranker generator.

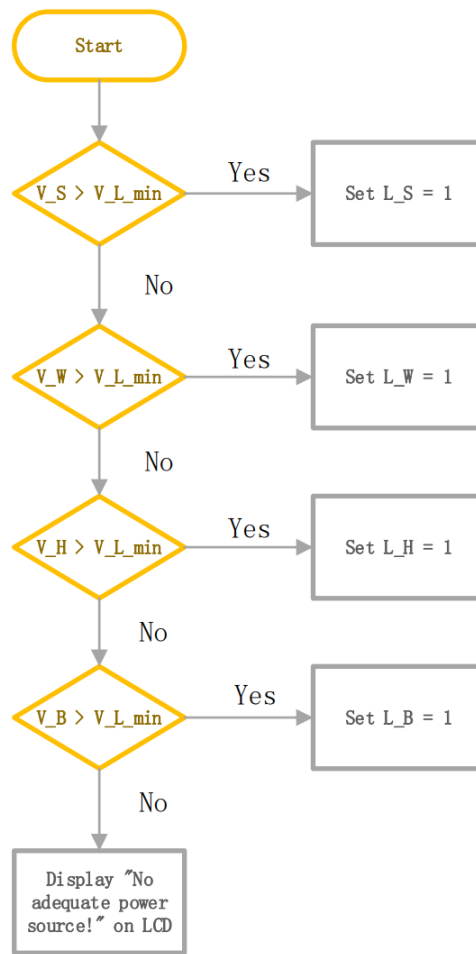

Figure 14: Control Load Logic

Algorithm 1 LOAD

```

1: if  $V_S > VL_{min}$  then
2:   DIGITALWRITE(L_S, 1)                                ▷ Socket is used to supply power
3: else if  $V_W > VL_{min}$  then
4:   DIGITALWRITE(L_W, 1)                                ▷ Wind turbine is used to supply power
5: else if  $V_H > VL_{min}$  then
6:   DIGITALWRITE(L_H, 1)                                ▷ Hand-cranker generator is used to supply power
7: else if  $V_B > VL_{min}$  then
8:   DIGITALWRITE(L_B, 1)                                ▷ Battery is used to supply power
9: else
10:  DIGITALWRITE(LCD, 1)                                ▷ Giving print signal to display subsystem
11: end if
  
```

2.3.3.3 Charge

The Arduino receives analog inputs from three power sources: 5 V DC from socket, Wind Turbine and Hand-cranker Generator and provides digital signals to the charging chip to control which one to charge the battery.

Similar to Load part, battery is provided with separate power sources to enhance circuit stability and facilitate control. Considering the stability of the three power sources, the priority order for selecting a power source is as follows: socket, wind turbine, and hand-cranker generator.

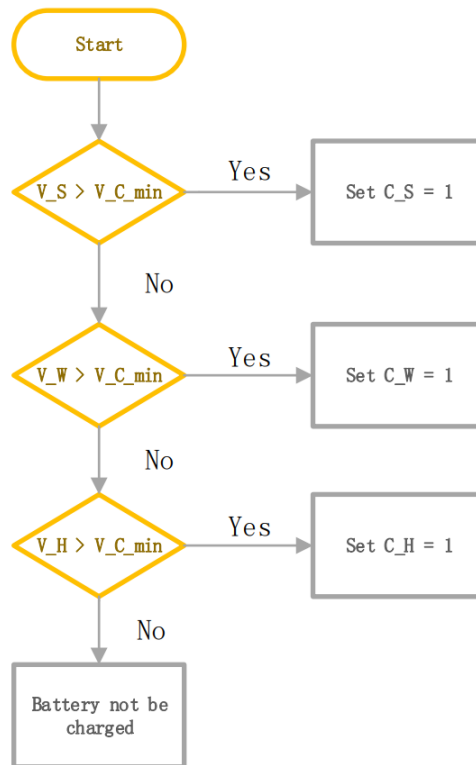

Figure 15: Control Charge Logic

Algorithm 2 CHARGE

```
if  $V_S > VC_{min}$  then  
2:   DIGITALWRITE(C_S, 1)           ▷ Using Socket to charge the battery  
else if  $V_W > VC_{min}$  then  
4:   DIGITALWRITE(C_W, 1)           ▷ Using Wind Turbine to charge the battery  
else if  $V_H > VC_{min}$  then  
6:   DIGITALWRITE(C_H, 1)           ▷ Using Hand-cranker Generator to charge the battery  
end if
```

2.3.3.4 Requirement and Verification

The Requirement and Verification table of Control Subsystem is shown in Table9.

2.3.4 Display Subsystem

The display subsystem presents the power condition of light bulb and fan as well as the battery .

$$Power = Voltage \times Current$$

To measure the power of the light bulb, fan, and battery, we need the voltage and current from the three components. Voltage value can be read directly through the analog read pin of the Arduino board while current cannot. Therefore, this subsystem integrates some current sensors to provide current information. The choice of the current sensor depends on various factors such as the type of current being measured, the magnitude of the current, the desired accuracy, and the specific requirements of the application.

Below are the current sensors we choose for different electrical components in our system.

- **Lightbulb(DC current) and Fan(DC current):** Allegro ACS758
The Allegro ACS758 is a precision linear Hall effect-based current sensor suitable for DC current measurement. It offers a low-resistance current path and voltage output proportional to the DC current being measured [5]. The ACS758 series comes in various models with different current rating options, allowing us to choose the one that matches the current range of the lightbulb and fan. This sensor provides accurate and reliable measurement of DC currents, making it suitable for lightbulb and fan applications where DC current is involved.
- **Battery(DC current):** INA219
The INA219 is a high-side DC current sensor that provides accurate measurement of current, voltage, and power consumption. It offers excellent precision and is commonly used for battery monitoring applications due to its low power consumption and wide dynamic range.



Figure 16: ACS758

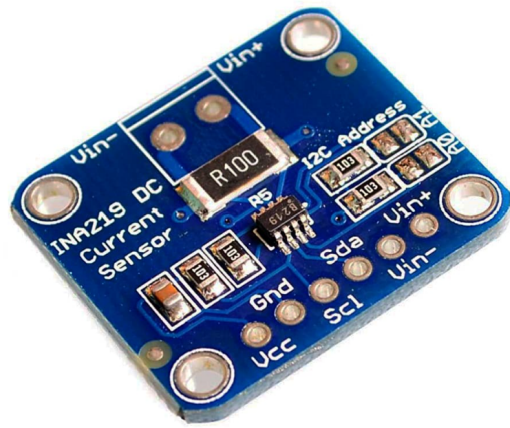

Figure 17: INA219

The Display Subsystem utilizes LCDs in Figure 18 showing numbers and screens in Figure 19 showing graphs to indicate the battery status as well as the power status of the fan and lightbulb. This provides visual feedback through the user interface, keeping the user informed about the operational condition of the system.



Figure 18: HD44780 LCD



Figure 19: Monitor

2.3.4.1 HD44780 LCD

HD44780 LCD is a 16*2 LCD that will take turns to display the number of the power for fan, lightbulb and battery. This is the most cost and time effective implementation since one can easily generate the signals needed in order to write to the LCD simply by writing a program in assembly or other higher level languages, such as C [6]. For a LCD, we need an Arduino UNO3 chip to control. LCD is a display unit that uses liquid crystals to produce visible images. When an electric current is applied to these special types of crystals, they become opaque and block the light from the backlight located behind the screen. As a result, specific areas will darken compared to other regions. This is how

characters are displayed on the screen. The display has an LED backlight and can show two lines, with up to 16 characters per line. On the display, you can see the rectangular box for each character as well as the pixels that make up each character, each rectangle being a grid of 5x8 pixels. The display is only in white and blue, with a blue background and white characters used to display text characters. Table 10 describes the specific usage of each pins in LCD.

Algorithm 3 Energy Monitoring and Display in LCD

```
1:  $C_F \leftarrow A0$  ▷ Current of Fan
2:  $V_F \leftarrow A1$  ▷ Voltage of Fan
3:  $C_L \leftarrow A2$  ▷ Current of Lightbulb
4:  $V_L \leftarrow A3$  ▷ Voltage of Lightbulb
5:  $V_B \leftarrow A4$  ▷ Voltage of Battery
6:  $C_B \leftarrow 0.2$  ▷ 240mA, where 1C = 1200mA
7: procedure SETUP
8:   lcd.begin(16, 2) ▷ set up the LCD's number of columns and rows
9:   lcd.clear() ▷ Clears the LCD screen
10:  PINMODE( $C_F$ , INPUT)
11:  PINMODE( $V_F$ , INPUT)
12:  PINMODE( $C_L$ , INPUT)
13:  PINMODE( $V_L$ , INPUT)
14:  PINMODE( $V_B$ , INPUT)
15: end procedure
16: while true do
17:    $c_f \leftarrow \text{ANALOGREAD}(C_F)$  ▷ analog Input
18:    $v_f \leftarrow \text{ANALOGREAD}(V_F)$ 
19:    $c_l \leftarrow \text{ANALOGREAD}(C_L)$ 
20:    $v_l \leftarrow \text{ANALOGREAD}(V_L)$ 
21:    $v_b \leftarrow \text{ANALOGREAD}(V_B)$ 
22:    $e_b \leftarrow \frac{1}{2} \cdot C_B \cdot v_b^2$  ▷ display the battery energy
23:   lcd.setCursor(0, 0)
24:   lcd.print(" Battery : ") ▷ Print a message to the LCD.
25:   lcd.setCursor(0, 1)
26:   lcd.print( $e_b$ )
27:   DELAY(10000) ▷ Wait for 10000 millisecond(s)
28:   lcd.clear()
29:    $e_f \leftarrow c_f \cdot v_f$  ▷ display the fan energy
30:   lcd.setCursor(0, 0)
31:   lcd.print(" Fan : ")
32:   lcd.setCursor(0, 1)
33:   lcd.print( $e_f$ )
34:   DELAY(10000)
35:   lcd.clear()
36:    $e_l \leftarrow c_l \cdot v_l$  ▷ display the lightbulb energy
37:   lcd.setCursor(0, 0)
38:   lcd.print(" Lightbulb : ")
39:   lcd.setCursor(0, 1)
40:   lcd.print( $e_l$ )
41:   DELAY(10000)
42:   lcd.clear()
43: end while
```

Name	Usage	Pin
GND	Ground	GND
VCC	Power supply	5V
Vo	control the contrast and brightness	5V
RS	Register Select	12
En	Enable the display	11
D0-D7	Data Bus	2-9
AK	Anode and Cathode	GND and VCC

Table 10: LCD Display Inputs

2.3.4.2 Power Monitoring and Display in Monitor

Arduino will separately get the number of instant current and voltage for each output and calculate the power showing in the LCD in turns. Table 11 shows how Arduino works for display. First we need to send the instant value of powers for outputs. Then we can use outside code to plot the figure.

Algorithm 4 Send Sensor Data Over Serial

```
1:  $C\_F\_PIN \leftarrow A0$                                 ▷ Fan current sensor pin
2:  $V\_F\_PIN \leftarrow A1$                                 ▷ Fan voltage sensor pin
3:  $C\_L\_PIN \leftarrow A2$                                 ▷ Lightbulb current sensor pin
4:  $V\_L\_PIN \leftarrow A3$                                 ▷ Lightbulb voltage sensor pin
5:  $V\_B\_PIN \leftarrow A4$                                 ▷ Battery voltage sensor pin
6:  $C\_B \leftarrow 0.2$                                     ▷ Battery current capacity in amperes
7: procedure SETUP
8:   SERIAL.BEGIN(9600)                                  ▷ Start serial communication at 9600 baud
9: end procedure
10: procedure LOOP
11:    $c\_f \leftarrow \text{ANALOGREAD}(C\_F\_PIN) * (5.0/1023.0)$     ▷ Fan current in Amps
12:    $v\_f \leftarrow \text{ANALOGREAD}(V\_F\_PIN) * (5.0/1023.0)$     ▷ Fan voltage in Volts
13:    $c\_l \leftarrow \text{ANALOGREAD}(C\_L\_PIN) * (5.0/1023.0)$     ▷ Lightbulb current in Amps
14:    $v\_l \leftarrow \text{ANALOGREAD}(V\_L\_PIN) * (5.0/1023.0)$     ▷ Lightbulb voltage in Volts
15:    $v\_b \leftarrow \text{ANALOGREAD}(V\_B\_PIN) * (5.0/1023.0)$     ▷ Battery voltage in Volts
16:    $power\_f \leftarrow c\_f * v\_f$                                 ▷ Power of the fan in Watts
17:    $power\_l \leftarrow c\_l * v\_l$                                 ▷ Power of the lightbulb in Watts
18:    $power\_b \leftarrow 0.5 * C\_B * v\_b * v\_b$                 ▷ Power of the battery in Watts
19:   SERIAL.PRINT( $power\_b$ )
20:   SERIAL.PRINT(",")
21:   SERIAL.PRINT( $power\_f$ )
22:   SERIAL.PRINT(",")
23:   SERIAL.PRINTLN( $power\_l$ )                                  ▷ Send data over serial in CSV format
24:   DELAY(1000)                                            ▷ Wait for 1 second before sending new data
25: end procedure
```

Algorithm 5 Real-time Data Plotting from Arduino using Python

```

1: IMPORT(serial)
2: IMPORT(matplotlib.pyplot as plt)
3: IMPORT(FuncAnimation from matplotlib.animation)
4: ser ← SERIAL.SERIAL('COM3', 9600)                                ▷ Initialize serial port
5: fig, axs ← PLT.SUBPLOTS(3, 1, sharex=True)                        ▷ Prepare subplot configuration
6: procedure ANIMATE(i, lines, axs)
7:   line ← ser.readline().decode('utf - 8').rstrip()              ▷ Read serial data
8:   if line then
9:     data ← SPLIT(line, ',')                                     ▷ Split the received CSV formatted data
10:    if data is valid then
11:      for all j in range(len(lines)) do
12:        lines[j].append(data[j])
13:        lines[j] ← lines[j][-50 :]                               ▷ Keep last 50 points
14:      end for
15:      for all ax, line in zip(axs, lines) do
16:        AX.CLEAR
17:        AX.PLOT(line)
18:        AX.SET_YLIM(0, 10)                                       ▷ Set y-axis limits
19:      end for
20:    else
21:      pass                                                       ▷ Ignore if data not in expected format
22:    end if
23:  end if
24:  FIG.CANVAS.DRAW                                               ▷ Redraw the subplots
25: end procedure
26: lines ← list of empty lists for 3 elements                       ▷ Create empty line lists
27: ani ← FUNCANIMATION(fig, animate, fargs = (lines, axs), interval = 1000)
28: PLT.SHOW

```

Name	Usage	Pin
C_F	Current of Fan	A0
V_F	Voltage of Fan	A1
C_L	Current of Lightbulb	A2
V_L	Voltage of Lightbulb	A3
V_B	Voltage of battery	A4

Table 11: Arduino Connection for display

2.3.4.3 Requirement and Verification

The Requirement and Verification table of Control Subsystem is shown in Table 13.

2.4 Tolerance Analysis

- **Electrical Contact Resistance of Plugs and Switches:** The electrical contact resistance of plugs and switches is a crucial factor in the reliability of the power distribution system. Over time, contact resistance can increase due to factors such as corrosion, wear, and material degradation. To mitigate this risk, historical data on the longevity and performance of various plug and switch materials can be utilized. Additionally, rigorous testing protocols can be established to ensure that the chosen components will not exceed a resistance of 0.2 ohms, which is double the nominal value but still within a range that does not compromise performance. For instance, a switch with a nominal resistance of 0.1 ohms is considered robust if testing shows minimal resistance change over tens of thousands of cycles under load conditions similar to those expected in actual use.
- **Battery Capacity and Discharge Rate:** The battery subsystem is essential for ensuring a continuous power supply, especially when manual generation is not available. A battery's voltage output tends to decrease as it discharges, which can affect the operation of the connected devices. To address this challenge, the selected battery must have a flat discharge curve that maintains the voltage above a minimum threshold throughout its discharge cycle. For example, a 12 V battery with a 5% voltage tolerance should not drop below 11.4 V until it reaches the recommended depth of discharge. This can be ensured by selecting a high-quality battery with a proven discharge profile and by incorporating a voltage regulator that compensates for voltage dips as the battery discharges, thereby safeguarding device operation within the desired voltage range.
- **Arduino ADC Resolution:** The resolution of the Arduino's analog-to-digital converter (ADC) directly affects the precision of sensor readings, which in turn influences the control system's ability to make fine-tuned adjustments to power output. With a 10-bit ADC, there are 1024 discrete levels available, which means that for a 0 - 5 V range, each level corresponds to approximately 4.88 mV. When applied to a current sensor with a 0 - 5 A output, this resolution translates to increments of about 4.88 mA. Given the system's power stability requirement of $\pm 1\%$, this resolution is adequate for representing small changes in current. To further refine the control system's response, software filters and averaging techniques can be applied to smooth out sensor noise and improve the fidelity of the sensor signal. This ensures more stable and accurate control of the power output to the fan and lightbulb.

#	Requirement	Verification
1	The subsystem must ensure that users can use these power generates to generate enough power supply for the load, with minimum voltage required for the voltage regulator for the loads 4.75 V.	After testing with a multi meter, we find that the hand crank generator can produce power with an average of 3.6 W, and the maximum output voltage of 9 V. The wind turbine can produce power with an average of 3.0 W, and the maximum output voltage of 10 V which is bigger than the minimum voltage required for the voltage regulator of 4.75 V. Thus, the two power generator are adequate for providing power supply.
2	The subsystem must be safe for children to interact with, which inquires the maximum voltage to be smaller than the safe voltage for human body, which is 36 v.	The 220 V AC to 7.5 V DC power adapter is fully encapsulated in insulating material and comes with short-circuit protection, so there's no need to worry about the dangers posed by high-voltage AC. The highest voltage produced by all power supplies is below 10 V, which is far less than the safe voltage for the human body, making it safe for use.
3	The subsystem's design should be easy to understand and fun to interact with.	Hand-cranked generators are common scientific educational tools for generating electricity. Wind turbines and wall sockets are also frequently used and seen in everyday life. Light bulbs and fans are also common small electrical appliances in homes. These power supplies have strong interactivity and are simple and straightforward enough, making them very suitable for children to understand knowledge about electrical energy.

Table 2: RV Table for User Interface Subsystem

#	Requirement	Verification
1	The power subsystem must be capable of receiving digital control signals from Arduino Uno (5 V as HIGH and 0 V as LOW) to seamlessly switch between different power sources for charging and loading.	The 7HA SSR-relay-module can receive control signal voltage ranging from 3 - 5 V, so the 5 V control input from Arduino is valid. Its typical operate time is 70 μs , while the typical release time is 0.7 ms , which ensures the switching is quick enough. This 7HA SSR relay module is a normally open relay module so that when it receives a HIGH signal at input pin, it acts as a complete circuit line. When it receives a LOW signal at input pin, it acts as an open circuit line.
2	The power subsystem must be able to operate safely under various power sources conditions without exceeding the maximum operate voltages of the control circuit elements. The maximum load current of 7HA SSR-relay-module is 7 A and the maximum load voltage of 7HA SSR-relay-module is 60 V. For the switching regulator, its maximum input voltage is 40 V.	The maximum power source available in our system is the peak power from a hand-generator, which is 9 V, 400 mA, and is far below the safe voltage and current of the relay module and the switching regulator chip.
3	The power subsystem must provide stable voltage supply to the light bulb and fan(both operates at 2.5 V) regardless of the switching of power source and the change of the load numbers.	The LM2575-ADJ chip is able to stabilize its output voltage using a feedback loop in its IC design. The output voltage is not related to the input voltage neither the load, and is entirely determined by the ratio of the two resistors at its Feed Back pin. which is $V_{out} = V_{ref}(1 + \frac{R_2}{R_1})$, where $V_{ref} = 1.23$ V. Here, we choose $R_1 = 1$ kohm and $R_2 = 1.033$ kohm to make sure a stable 2.5 V voltage output to the light bulb and fan [4].

Table 4: RV Table for Power Subsystem

#	Requirement	Verification
1	The system must be capable of reading and processing voltage values from socket, hand crank generator and wind turbine using Arduino's analog read pin, which can read voltage values ranging from 0 to 5V.	Our three power supplies generate voltages of 5 to 10 V and we added a voltage divider circuit at the output, given by $V = V_{in} \times \left(\frac{R_1}{R_1+R_2}\right)$. We use $R_1 = R_2 = 1k$ Ohm, which halves the signal read by the Arduino, thus ensuring that the Arduino can safely and accurately read the voltage from each power source.
2	The control system should have a command response time of no more than 1 second to ensure immediate feedback.	Through performance testing, usability testing, and regression testing, the system's capability to achieve a command response time of no more than 1 second will be verified. Meeting this requirement ensures immediate feedback to users, enhancing the overall user experience and system usability.
3	The control subsystem must ensure prolonged endurance of more than 24 hours, and the Arduino's input/output can only control without affecting the power routing circuitry.	We do not use any power source from the power routing to supply the Arduino, but rather power it with two replaceable batteries to minimize the Arduino's consumption as a circuit component. We plan to use two 3.7 V 3300 mAh lithium batteries in series for the Arduino's V_{in} . Assuming the Arduino typically operates at 50 mA, the endurance of the two batteries would be 60 - 90 hours, which is sufficient for extended operation.

Table 9: RV Table for Control Subsystem

#	Requirement	Verification
1	The display system must be capable of obtaining current value of 0 to 3 A current from the light bulb, fan, and battery with the accuracy within 1%.	For the X050 sensor, from the data sheet, we find that : The Primary Sampled Current (I_p) range is from a minimum (Min.) of -50 A to a maximum (Max.) of 50 A. The is within $\pm 1.2\%$. Thus, it satisfies the measuring requirement of light bulb and fan. The INA219 current sensor has a measuring range of -40 A to 40 A and precision of 0.5% , which is enough for measuring current of battery accurately.
2	The control system should have a command response time of no more than 1 second to ensure immediate feedback.	Through performance testing, usability testing, and regression testing, the system's capability to achieve a command response time of no more than 1 second will be verified. Meeting this requirement ensures immediate feedback to users, enhancing the overall user experience and system usability.
3	The display subsystem must ensure fast enough display update but also slow enough for the monitor to display the number clearly. The desired updating time is 0.75 s to 1.25 s.	We use <code>DELAY(1000)</code> in our Arduino code to ensure that the displayed value is updated every 1 s.

Table 13: RV Table for Display Subsystem

3 Cost and Schedule

3.1 Cost Analysis

1. Labor Cost

According to the average salary of UIUC ECE undergraduates, our hourly wage is 60 \$, and our average working hours is 20 hours per week. For this project, we approximately work 13 full weeks. Then we can get following labor cost table, the resulting total labor cost would be around 52000 \$ as shown in Table 14.

Name	\$/Hour	Hours/Week	Weeks	Cost (\$)
Yunfei	60	20	13	15600
Jingjing	60	20	13	15600
Jiabao	60	20	13	15600
Xiaoyi	60	20	13	15600
Total	60	80	13	62400

Table 14: Labor Cost

2. Material Cost

Name	Description	Manufacturer	Quantity	Price	Cost
Arduino UNO R3	Main control board	Arduino	2	¥164	¥328
HD44780 LCD	A display unit that uses liquid crystals to produce visible images	Raylid	2	¥7.5	¥15
Allegro ACS758	Current sensors for lightbulb and fan	Allegro MicroSystems	2	¥20	¥40
INA219	Current sensor for battery	Texas Instruments	1	¥10	¥10
SDD-7HA	Relay module: Input voltage: 3 - 5 V	XYF	7	¥10	¥70
LM 2575 ADJ	Switching regulator: Input voltage: 4.75 - 40 V	Jinkesheng	2	¥0.62	¥1.24
Bulb	Electrical appliance: 2.5 V, 0.3 A	Yuanning	5	¥1	¥5
Fan	Electrical appliance: 2.5V	KQU	1	¥1.86	¥1.86
Wind turbine	Generator: 5 V, 3 W	Gabosun	1	¥19.8	¥19.8
Hand crank	Generator: 9 V, 3 W	Qimeng	1	¥8.8	¥8.8
Power Adapter	220 V AC - 7.5 V DC	Dingsheng	1	¥10	¥10
Lithium battery pack	7.4 V, 13600 mAh	Baidong	1	¥134.8	¥134.8
Total					¥644.5

Table 16: Material Cost

3.2 Schedule

WEEK	Yunfei Lyu	Jingjing Qiu	Jiabao Shen	Xiaoyi Han
2/19/2023	Form the team	Form the team	Form the team	Form the team
2/26/2023	Write Request for Approval (RFA) and contract information	Write Request for Approval (RFA) and contract information	Write Request for Approval (RFA) and contract information	Write Request for Approval (RFA) and contract information
3/4/2023	Write Proposal	Write Proposal	Write Proposal	Write Proposal
3/11/2023	Download software for programming and design	Purchase hardware for circuit and control	Learn how to code in Arduino	Learn how to code in Arduino
3/18/2023	Learn how to use kicad	Learn how to use kicad	Learn the basic operations of Arduino related to PID	Learn the basic grammar of Arduino about I/O stream
3/25/2023	Design power input circuit in Kicad	Design power control circuit in Kicad	Build the basic circuit and coding for the Arduino I/O.	Write basic codes for the Arduino I/O and charging/discharging logic for battery

4/1/2023	Continue designing power input circuit in Kicad	Continue designing power control circuit in Kicad	Add LCD display and improve the power-distribution part in our simulation	Code for power distribution and power/battery level display
4/8/2023	Design the circuit framework for multi-source power selection	Finalize the multi-source power selection circuit design and draw it on Kicad	Finishing the whole process of control subsystem in simulation	Finish the whole process of display subsystem in simulation
4/15/2023	Do the unit test for power subsystem	Do the small demo for power subsystem	Add LCD display and improve the power-distribution part in our simulation	Start to build the hardware part of Arduino, breadboard, LCD, and screen
4/22/2023	Connect the hardware and software together	Debug for the power subsystem in hardware	Load the control logic in Arduino	Load the display logic in LCD
4/29/2023	Do the physical design	Design a beautiful user interface	Connect the hardware and software together	Connect the hardware and software together
5/6/2023	Prepare for the presentation	Prepare for the presentation	Prepare for the presentation	Prepare for the presentation
5/13/2023	Prepare for the public display	Prepare for the public display	Prepare for the public display	Prepare for the public display
5/20/2023	Complete the final report	Complete the final report	Complete the final report	Complete the final report

4 Ethics and Safety

4.1 Ethics

- **Public Safety:** Ensuring the safety of the public is paramount in any engineering project. The IEEE Code of Ethics emphasizes the importance of prioritizing safety, health, and welfare of the public in professional activities [7]. Misuse or malfunctions of the smart power routing system could lead to electrical hazards, such as shocks, fires, or system failures. Therefore, we will put up warning signs and implement comprehensive safety protocols during system development and usage during system development and usage. We will integrate fail-safe mechanisms and emergency shut-off features to minimize the risk of accidents, ensuring the system is both safe and reliable for all users.
- **Academic Integrity and Citation:** Maintaining academic integrity involves ensuring all research and development work is conducted honestly, without plagiarism, and properly credits sources of knowledge and inspiration. The IEEE Code of Ethics highlights the importance of honesty in all professional endeavors [7]. We will rigorously follow academic citation practices, crediting all external sources of information, data, and ideas used in the development of the smart power routing system. Tools and processes will be implemented to check for inadvertent plagiarism, ensuring that all project documentation and publications accurately reflect the contributions of external sources.
- **Environmental impact:** The development and use of smart power routing systems have potential environmental implications, including energy consumption and electronic waste. Efforts will be made to use sustainable materials and to design the system for easy recycling at the end of its life following the IEEE Code of Ethics [7].

4.2 Safety

- **Electric Shock Risk:** Handling live wires, especially when integrating manual generators and electrical outlets with 220 v power supply, poses a risk. The International Electrotechnical Commission (IEC) 60364 series sets forth standards for the electrical installations emphasizing the need for protective measures against electric shock and ensuring the safety of installations under both normal and fault conditions [8]. Therefore, we should follow these regulations to ensure all components are properly insulated and implementing fail-safes to disconnect power in case of a short circuit are essential.
- **Overheating and Fire Risk:** The IEC 62368-1 states that equipment must be designed to prevent the risk of fire and overheating, even under fault conditions, by implementing safeguards such as thermal protection and limiting energy sources. [8] In our system, components such as batteries and microcontrollers can overheat, especially under continuous operation or fault conditions. It is essential that we use components within their rated capacities and incorporating thermal cutoffs to miti-

gate this.

- **Mechanical Safety:** The hand-crank generators and pneumatic turbines involve moving parts. We can follow guidance from ISO 12100 series, "Safety of machinery - General principles for design - Risk assessment and risk reduction." to use protective casings and guards to prevent injury from moving parts.[9]

References

- [1] Edubirdie. ""The Advantages of Adopting the Smart Electrical Grid"." (Sep. 2022), [Online]. Available: <https://edubirdie.com/examples/the-advantages-of-adopting-the-smart-electrical-grid/> (visited on 02/27/2024).
- [2] X. He, T. Li, O. Turel, Y. Kuang, H. Zhao, and Q. He, "The impact of stem education on mathematical development in children aged 5-6 years," *International Journal of Educational Research*, vol. 109, p. 101795, 2021, ISSN: 0883-0355. DOI: <https://doi.org/10.1016/j.ijer.2021.101795>. [Online]. Available: <https://www.sciencedirect.com/science/article/pii/S0883035521000653>.
- [3] J. Chesloff, "Stem education must start in early childhood," *Education Week*, vol. 32, no. 23, pp. 27–32, 2013.
- [4] S. Regulator, "Lm2575, ncv2575," 2009.
- [5] R. Dickinson and A. Friedrich, "Using allegro current sensors in current divider configurations for extended measurement range," *Allegro microsystems and applications*, 2005.
- [6] N. R. Laddha and A. Thakare, "A novel approach for displaying data on lcd directly from pc using fpga," *International Journal of Emerging Science and Engineering (IJESE)*, vol. 1, 2013.
- [7] IEEE. ""IEEE Code of Ethics"." Accessed: 4 March 2021. (Jun. 2020), [Online]. Available: <https://www.ieee.org/about/corporate/governance/p7-8.html>.
- [8] International Electrotechnical Commission. ""Electrical regulations and standards"." (2017), [Online]. Available: https://www.electrical-installation.org/enwiki/Electrical_regulations_and_standards.
- [9] *ISO 12100:2010 - Safety of machinery – General principles for design – Risk assessment and risk reduction*, Status: Published. Publication date: 2010-11. Stage: International Standard to be revised [90.92]. Edition: 1. Number of pages: 77. Technical Committee: ISO/TC 199. ICS: 13.110, International Organization for Standardization, Nov. 2010. [Online]. Available: <https://www.iso.org/standard/51528.html>.