

ECE 445

SENIOR DESIGN LABORATORY

DESIGN DOCUMENT

INTELLIGENT FIRE PROTECTION ECOSYSTEM

Team #16

XIAOHUA DING

(xiaohua5@illinois.edu)

HONGLEI ZHU

(honglei3@illinois.edu)

JIAWEI ZHU

(jiawez6@illinois.edu)

YIYANG LIU

(yiyang24@illinois.edu)

TA: Jiahao Chen

March 24, 2024

Contents

| | | |
|----------|-------------------------------------------------|-----------|
| 1 | Introduction | 1 |
| 1.1 | Problem and Solution | 1 |
| 1.2 | Background | 1 |
| 1.3 | Visual Aid | 2 |
| 1.4 | High-level requirements list | 3 |
| 2 | Design | 5 |
| 2.1 | Block Diagram | 5 |
| 2.2 | Physical Design | 6 |
| 2.3 | Function Overview&System requirements | 9 |
| 2.3.1 | Smoke Sensor Subsystem | 9 |
| 2.3.2 | Current Alarm Subsystem | 10 |
| 2.3.3 | Combustible Gas Sensor Subsystem | 10 |
| 2.3.4 | Manual Fire Call Points Subsystem | 11 |
| 2.3.5 | Audible and visual alarm | 12 |
| 2.4 | Tolerance (Risk) Analysis | 13 |
| 3 | Cost & Schedule | 15 |
| 3.1 | Cost | 15 |
| 3.2 | Schedule | 16 |
| 4 | Ethics and Safety | 17 |

1 Introduction

In today's rapidly evolving urban landscape, ensuring the safety and security of buildings against fire hazards remains a paramount concern. Traditional fire protection systems, while effective to a certain extent, often fall short in addressing the dynamic challenges posed by modern infrastructure and diverse fire risks. Recognizing the need for a more intelligent and comprehensive approach to fire safety, our project endeavors to introduce the Intelligent Fire Protection Ecosystem.

1.1 Problem and Solution

The objective of our project is to address the shortcomings of traditional fire protection systems by introducing the Intelligent Fire Protection Ecosystem. Traditional fire detection and alarm systems often lack the sophistication needed to accurately detect different gases and respond to fire incidents in a timely manner. The use of a single sensor is prone to false alarms. The traditional fire alarm detector sensor is relatively single, the judgment of the fire is not comprehensive enough, it is easy to occur false touch false alarm. Users regularly receive false fire alarms, which will cause the real discovery of the fire, take it lightly, and can not make timely escape, wasting the golden time to escape.

Our proposed solution aims to enhance the capabilities of conventional fire alarm equipment by integrating traditional sensor technologies and leveraging WiFi connectivity through the ESP8266 chip. By doing so, we seek to achieve more precise and reliable fire detection capabilities, allowing for early detection of smoke, hazardous gases, and temperature variations. Through a mobile application interface, users can receive real-time warnings and monitor changes in gas concentrations, empowering them to take proactive measures to mitigate fire hazards and ensure the safety of occupants and assets.

1.2 Background

The context of the problem is the inability of traditional fire protection systems to effectively respond to the ever-changing challenges posed by the modern built environment, with limited scope and means of data transmission. According to Illinois Fire Departments, there were over 1.4 million incidents, 92 civilian lives were lost and over \$476 million in property damage resulted from fires, according to the Office of the Illinois State Fire Marshal. and over \$476 million in property damage resulted from fires in 2022[1]. As urbanization and technological advances continue to reshape our cities, the need for smarter, more responsive fire safety solutions is increasingly evident. According to the United States Fire Department,

there is a fire in a residential area every 85 seconds and these fires account for almost 80 percent of all fire-related deaths[2, 3]. Traditional systems, which rely on simple detection methods and manual intervention, are mainly classified into photoelectric smoke detectors and ionization smoke detectors[4]. However, because conventional smoke alarms use a point light source (as shown in Figure 1), when detecting a single type of gas or smoke, the alarm threshold depends only on the shape of the detection chamber and the position and intensity of the light-emitting element (LED), which makes it difficult to adjust, does not provide real-time feedback on the concentration of toxic or combustible gases, and is susceptible to false alarms due to the presence of a single sensor. For example, smoke generated at low ambient temperatures is not recognised as a fire, whereas a conventional alarm would. It is therefore essential to integrate multiple sensors and provide real-time feedback in an alarm.

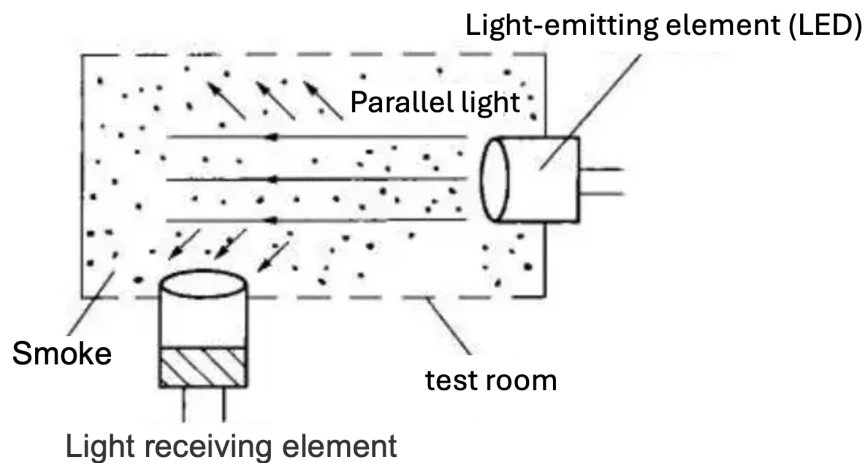

Figure 1: Schematic of Traditional Photoelectric Smoke Alarms

1.3 Visual Aid

The physical design of the Smart Fire Ecosystem is shown in Figure 2. The figure illustrates the integration of our solution with relevant external systems (e.g., mobile devices for remote monitoring) in the built environment. The dotted lines indicate the connections between our system and external components, emphasizing the seamless interaction between them. The sensor on the left will transmit electrical signals to the mobile device (phone) via the built-in ESP8266 chip after detecting smoke, hazardous gases, etc. The feedback signals (I/O data) will also

be transmitted to the alarm via the built-in ESP8266 chip after the program has given feedback.

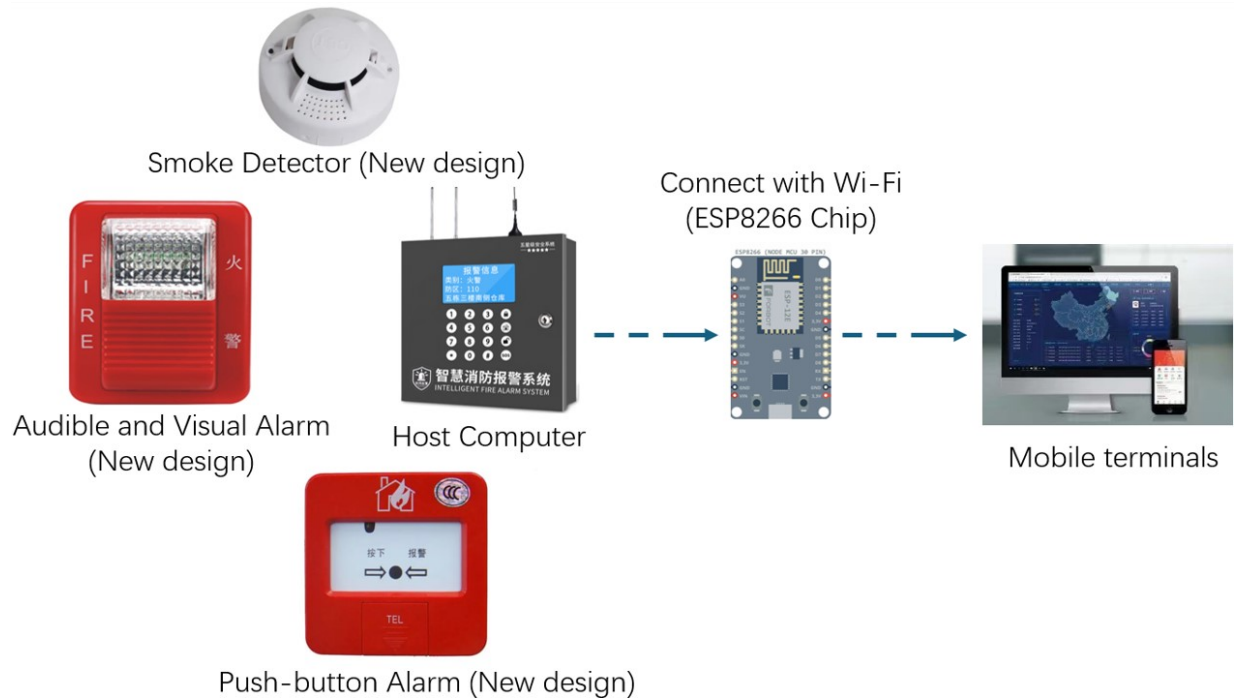

Figure 2: Physical Design for Intelligent Fire Protection Ecosystem

1.4 High-level requirements list

- Fire Detection Accuracy:**
 The system must highly accurately and intelligently detect at least three different causes (e.g., high temperatures, combustible gases, etc.) of fire accidents and minimize false alarms by displaying the change in gas concentration (LEL) in real time on a mobile device.
- Remote Monitoring and Control:**
 Remote monitoring and control functionalities must exhibit a response time of less than 5 seconds, enabling users to swiftly assess and manage fire-related emergencies from a distance.
- Power:**
 The batteries of the equipment must be able to provide sufficient power and a low-battery warning module added to warn when the battery level falls

below 20%. The power consumption of the electronic equipment needs to be strictly controlled and the batteries do not need to be replaced for at least 3 months, as the equipment needs to be thoroughly checked every 3 months according to the program to ensure safety.

2 Design

2.1 Block Diagram

As shown in Figure 2, our design has four blocks: Power supply, Control unit, Sensor module and Wi-Fi IC.

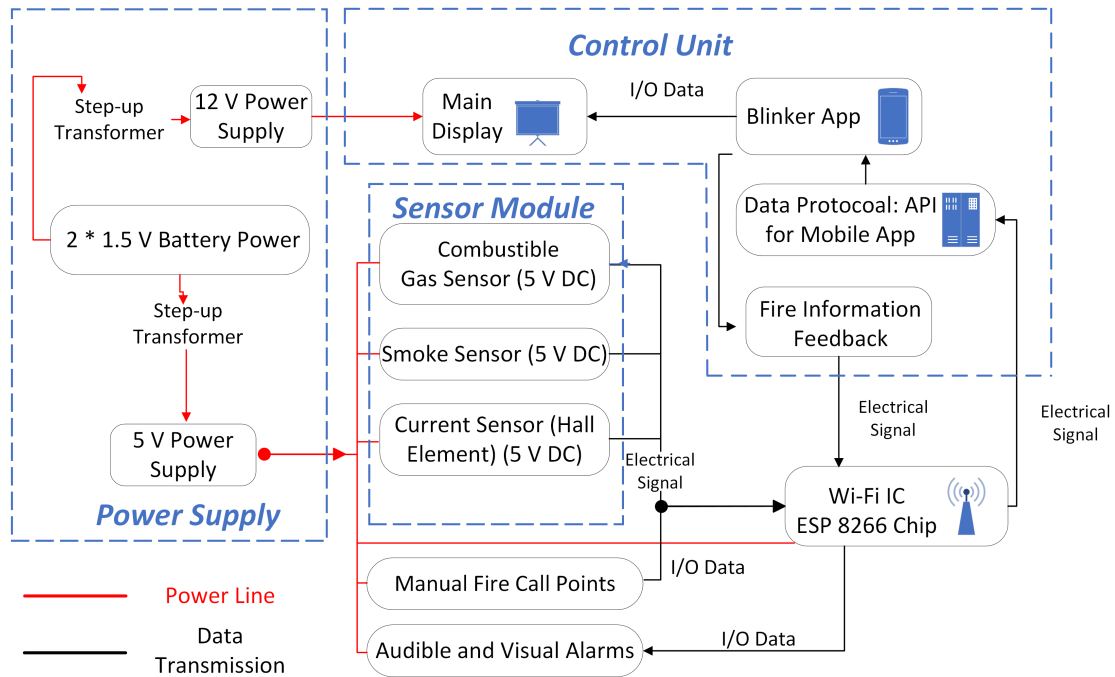

Figure 3: Block Diagram

Power Supply:

Power supply supplies power to the entire fire protection system. It accepts two 5 volt DC current input power supplies and distributes them to the various subsystems through transformers. Control unit requires 12V power supply and sensors and ESP8266 require 5V power supply, this process will be done through the step-up transformer in the PCB.

Control unit:

Control unit is the hub of the fire detection system. It receives signals from smoke sensors and other detection devices through the inbuilt ESP8266 chip, initiates the response mechanism and displays relevant information on the main display. In terms of feedback, real time information about fire status, sensor data and indications are provided to the user through a mobile application and the inbuilt

ESP8266 chip and connected to external devices.

Sensor Module:

- Smoke Sensor: As shown in Figure 3, this sensor detects smoke particles in the environment and sends a signal to the fire alarm control panel via the built-in ESP8266 chip. It is powered by a 5 V DC supply from Power Supply. (As shown in Figure 2)
- Combustible Gas Sensor: As shown in Figure 3, this sensor detects the concentration of combustible gases in the environment and sends a signal to the fire alarm control panel via the built-in ESP8266 chip. It is powered by a 5 V DC supply from Power Supply. (as shown in Figure 2)
- Current Sensor (Hall Element): Currently, fires caused by short circuits are occurring frequently [5]. This sensor detects changes in the current in the circuit by means of a Hall Element and sends an electrical signal to the mobile device (Phone) by means of the built-in ESP8266 chip, which is powered by a 5 V DC power supply from Power Supply. (As shown in Figure 2)

2.2 Physical Design

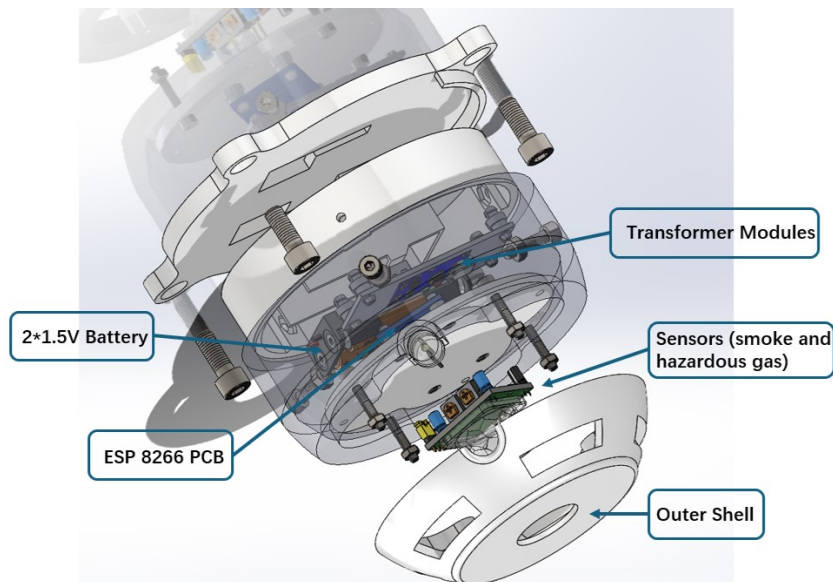

Figure 4: Initial Modelling of Smoke Alarms

As shown in Figure 3, it is our group's initial smoke alarm modeling. It consists mainly of a base, a chip and battery compartment, and an outer shell. Since national standards[6] require that spherical objects with a diameter of 1.3 mm cannot penetrate into the detection chamber, it is necessary to wrap the air inlet of the housing with a mesh cover. The battery and PCB, including ESP8266, are placed in a relatively airtight space by a partition so that smoke particles do not damage them. The alarm has a built-in temperature sensor as well as a smoke sensor to provide accurate alarms. It can also be converted into a combustible gas sensor by quickly changing the type of sensor.

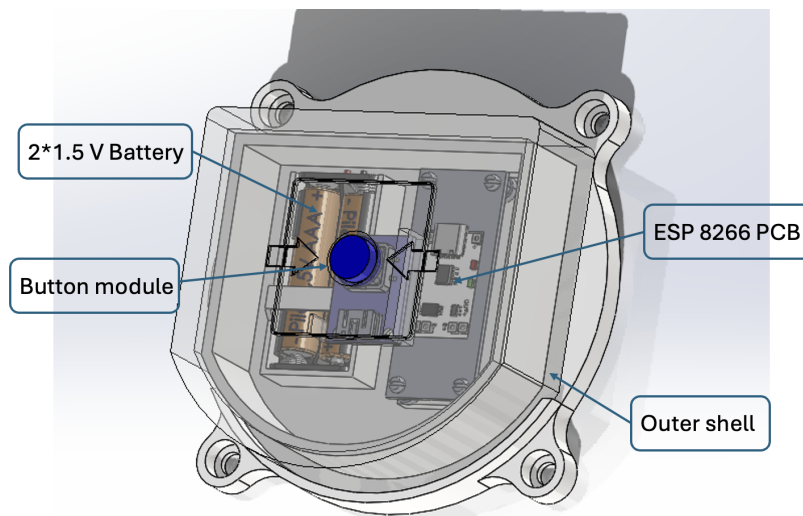

Figure 5: Initial Modelling of Push-button Alarms

As shown in Figure 4, it is our group's initial modeling of a push button alarm. It consists primarily of a base, a chip and battery compartment, a button assembly, and a housing. The case is clearly labeled and has an acrylic cover to prevent accidental contact.

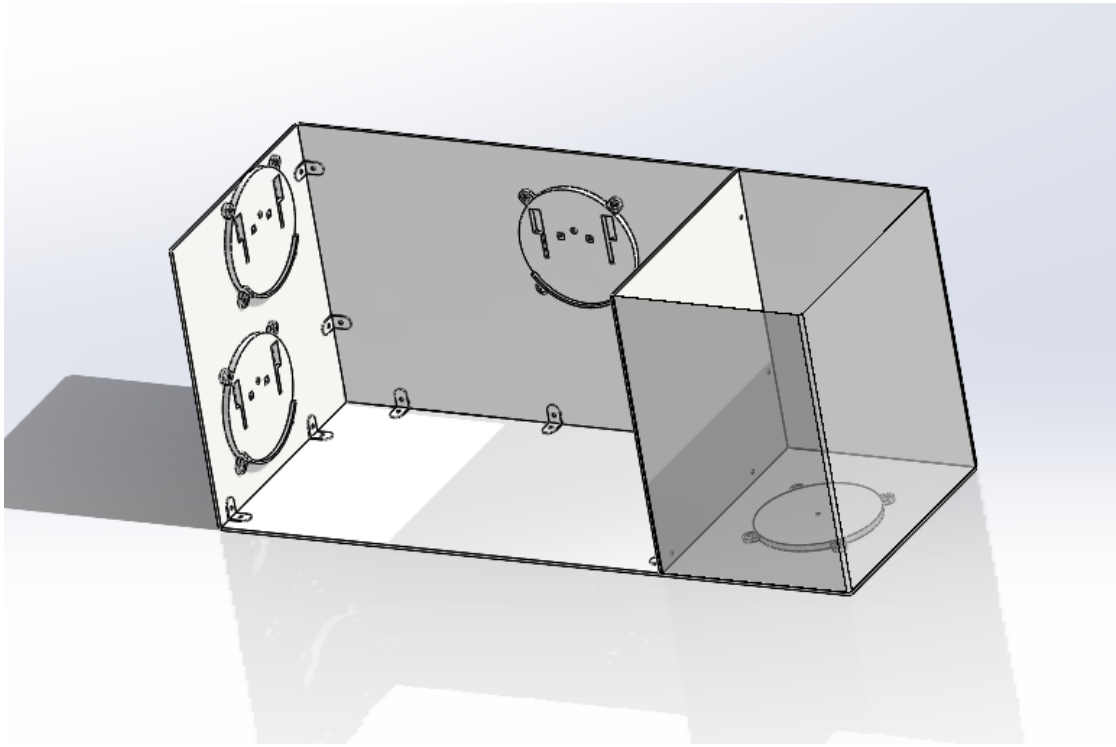

Figure 6: Initial Modelling Box for Demo

For the final demo, our team design a box, as shown in Figure 5, made of aluminum and acrylic to put all of our products. Especially, the smoke alarms and dangerous gas alarms will be put in the acrylic box for safety, and our team will fill the acrylic box with smoke and gas separately.

2.3 Function Overview&System requirements

2.3.1 Smoke Sensor Subsystem

The smoke alarm consists of an esp8266 chip board as the control and communication hub, linking an MQ-2 smoke sensor module, and a DHT11 temperature and humidity sensor module as the detection part, and a buzzer as the alarm device.

The smoke sensor in this ecosystem functions by continuously monitoring the environment for smoke particles. When detected, it sends a signal to the central system to initiate an alert. This sensor interfaces with the central monitoring system, through a wireless connection, to ensure that smoke detection is quickly communicated and actioned upon.

| Requirement | Verification |
|-------------------------------------------------------------------------------------------------------------------------------------------------------------------------------------------------------------------------------------------------------------------------------------------------------------------------------------------------------------------------------------------------------------------------------------------------------------------------------------------------------------------------------------------------------|-------------------------------------------------------------------------------------------------------------------------------------------------------------------------------------------------------------------------------------------------------------------------------------------------------------------------------------------------------------------------------------------------------------------------------------------------------------------------------------------------------------------------------------------------|
| <ul style="list-style-type: none">• When the smoke concentration changes at the scene, the cell phone can display the smoke concentration in real time.• When the temperature of the scene changes, the cell phone can display the temperature in real time.• When the smoke concentration reaches a certain value (60%)[7, 6], the buzzer starts to sound the alarm.• The cell phone can get the alarm information, if it is a false alarm, you can eliminate the alarm remotely through the cell phone[8]. | <ul style="list-style-type: none">• Use the smoke produced by cigarettes to spray to the smoke sensor, observe whether the smoke concentration and temperature on the cell phone display and change[9].• When the smoke concentration reaches a certain value, the buzzer pin receives a high electric frequency, buzzer alarm.• When the smoke concentration exceeds the standard and the buzzer continues to alarm, press the mute button on the cell phone to determine whether it can be remotely silenced. |

Table 1: Requirement and Verification for Smoke Sensor Subsystem

2.3.2 Current Alarm Subsystem

The current alarm consists of an esp8266 chip board as the control and communication hub, linking a hall module as the detection part[10] and a buzzer as the alarm device.

| Requirement | Verification |
|--------------------------------------------------------------------------------------------------------------------------------------------------------------------------------------------------------------------------------------------------------------------------------------------------------------------------|--------------------------------------------------------------------------------------------------------------------------------------------------------------------------------------------------------------------------------------------------------------------------------------------------------------------------------------------------------------------------------------------|
| <ul style="list-style-type: none">• When the current in the wire changes, the cell phone can display the real-time current size in real time.• When the current in the wire is too large or the amount of change exceeds a certain ratio, then the buzzer alarm, the cell phone sends a reminder. | <ul style="list-style-type: none">• Use a wire, both sides of the access to the student power supply, adjust the current in the wire, observe the cell phone can real-time display of the current size.• When the current in the wire is too large or change the amount of more than a certain rate (15%), to determine whether the buzzer can send an alarm signal |

Table 2: Requirement and Verification for Current Alarm Subsystem

2.3.3 Combustible Gas Sensor Subsystem

The combustible gas detection platform utilizes the ESP8266 microcontroller for its core processing capabilities, enabling wireless communication and data handling. It incorporates the MQ-5 sensor for detecting concentrations of combustible gases, alerting users to potential fire hazards. The system is also equipped with a DHT11 sensor to monitor ambient temperature, providing data crucial for accurate gas detection. In either case, the platform triggers a buzzer as an immediate auditory warning[11].

| Requirement | Verification |
|-----------------------------------------------------------------------------------------------------------------------------------------------------------------------------------------------------------------------------------------------------------------------------------------------------------------------------------------------------------------------------------------------------------------------------------------------------------------------------------------------------------------------------------------------------------------------------------|-------------------------------------------------------------------------------------------------------------------------------------------------------------------------------------------------------------------------------------------------|
| <ul style="list-style-type: none"> • When the combustible gas intensity changes, the app can display intensity value. • When the temperature of the scene changes, the app can display the temperature value. • When the combustible gas intensity reaches the threshold value(around 990), the buzzer triggers. • When the temperature reaches the threshold value, the buzzer triggers. • The cell phone can get the alarm information, if it is a false alarm, you can eliminate the alarm remotely through the cell phone. | <ul style="list-style-type: none"> • Use lighter to simulate a fire, satisfy both combustible gas and temperature requirements. • After the alarm is triggered, we manually eliminate the alarm through the cell phone. |

Table 3: Requirement and Verification for Current Alarm Subsystem

2.3.4 Manual Fire Call Points Subsystem

The Audible and visual alarm uses an ESP8266 microcontroller as its processing core for data processing and wireless communication. It receives alarm signal from the Manual Alarm Push Button System and successfully trigger the alarm[12].

| Requirement | Verification |
|----------------------------------------------------------------------------------------------------------------------------------------------------------------------------------|----------------------------------------------------------------------------------------------|
| <ul style="list-style-type: none"> Manually push the button to trigger alarm signal to trigger alarm in another separate esp8266 Audible and visual alarm module. | <ul style="list-style-type: none"> Manually push the button to trigger alarm. |

Table 4: Requirement and Verification for Manual Fire Call Points Subsystem

2.3.5 Audible and visual alarm

The Audible and visual alarm uses an ESP8266 microcontroller as its processing core for data processing and wireless communication. It receives alarm signal from the Manual Alarm Push Button System and successfully trigger the alarm.

| Requirement | Verification |
|---------------------------------------------------------------------------------------------------------------------------------------|------------------------------------------------------------------------------------------------------------------------------|
| <ul style="list-style-type: none"> Wireless communication with The Manual Alarm Push Button System and alarm function. | <ul style="list-style-type: none"> Audible and visual alarm from the buzzer when manually pushing the button. |

Table 5: Requirement and Verification for Manual Fire Call Points Subsystem

2.4 Tolerance (Risk) Analysis

The most critical and potentially risky aspect of a fire protection system lies in the accurate detection of fire incidents by smoke sensors, also known as the smoke alarm subsystem. Ensuring the viability of the functionality of this critical subsystem requires rigorous mathematical analyses or simulations to assess its performance under a variety of environmental conditions and potential sources of interference. Factors such as smoke particle size, density and distribution patterns, as well as ambient lighting conditions and airflow dynamics can have a significant impact on the effectiveness of smoke detection. Although the test conditions are specified in national standards, this newly designed smoke alarm requires intelligent judgement in combination with temperature and other factors. Therefore, in order to verify its feasibility, we need to consider the diffusion changes of smoke and temperature in the environment. Due to the limitation of the demo box size, we can't fully simulate the real house scene, so we need to use the smoke diffusion equation (1) and the temperature change equation (2) to make calculations and tests to make it comply with the standard.

$$c(x, y, z, H) = \frac{Q}{2\pi\bar{u}\sigma_y\sigma_z} \exp\left(-\frac{y^2}{2\sigma_y^2}\right) \left\{ \exp\left[-\frac{(z-H)^2}{2\sigma_z^2}\right] + \exp\left[-\frac{(z+H)^2}{2\sigma_z^2}\right] \right\} \quad (1)$$

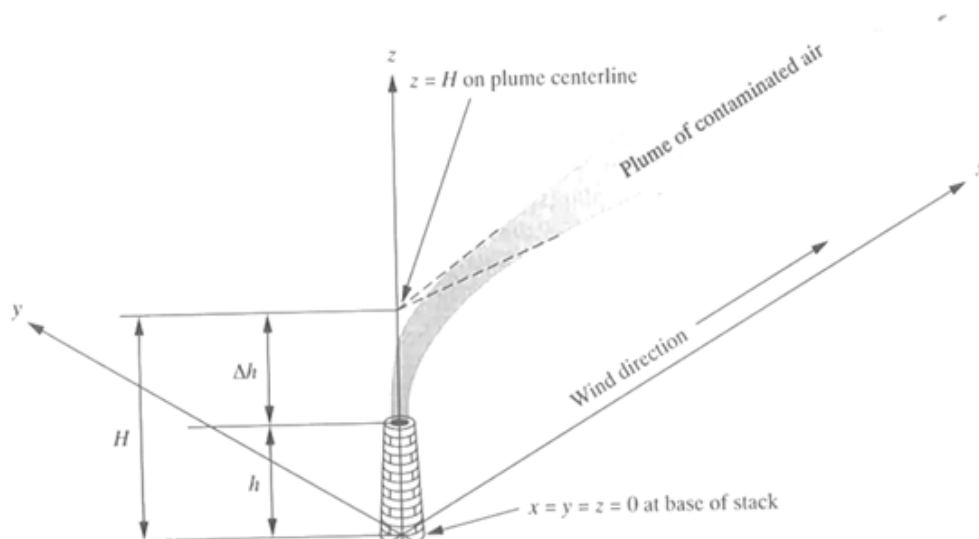

Figure 7: Schematic of smoke dispersion

As shown in Figure 7, in equation (1), c is the smoke concentration (unit: mg/m^3), Q is the source strength (unit: mg/s). u is the average wind speed (unit: m/s).

In the demo box, the average wind speed, u , is defaulted to 0 m/s . σ_y and σ_z are diffusion parameters on the y- and z-axes expressed as standard deviation of concentration. H is the leakage effective height.

$$E = KM\Delta t = \frac{\Delta t_m}{\frac{1}{KA}} \quad (2)$$

In equation (2), E is the heat transfer rate (unit: W), K is the total heat transfer coefficient (unit: $W/(m^2 * K)$). A is the heat transfer area (unit: m^2). Δt_m is the average temperature difference (unit: $^{\circ}C$).

With this two equations, we can calculate the specific concentration and temperature of a certain point that we will place our smoke alarms, and adjust the domain of our product depending on the results of the calculation.

3 Cost & Schedule

3.1 Cost

| Part | Cost (Experiment) | Cost (Demo) |
|------------------------------------|-------------------|------------------|
| ESP8266 CP2102 IoT Module Chip | 21.8*5 | - |
| DHT Temperature Control Module | 6.27*2 | 6.27*2 |
| MQ-2 Smoke Gas Sensor Module | 7.5 | 7.5 |
| MQ-5 Combustible Gas Sensor | 7.7 | 7.7 |
| Current Inductance Module 5A Range | 5.28 | 5.28 |
| PCBs (PCBWay) | 150*5 | 150*5 |
| 1.5 V Battery | 19.8 | 19.8 |
| Battery box | 5*4.5 | 5*4.5 |
| PLA (3D Printing Material) | 400(approximate) | 200(approximate) |
| Aluminum Plate (customized size) | 150 | 150 |
| Acrylic Plate (customized size) | 200 | 200 |
| Buzzers | 2.77 | 2.77 |
| Large Button Module | 2 | 2 |
| Light and Sound Alarms | 15 | 15 |
| Various types of Bolts and Nuts | 45 | 45 |
| TOTAL (RMB) | 1549.09 | 1240.09 |
| TOTAL (USD) | \$221.30 | \$177.16 |

Table 6: Cost Table

3.2 Schedule

| Date | Honglei Zhu | Xiaohua Ding | Jiawei Zhu |
|------------|------------------------------------------|------------------------------------------------------------------|-------------------------------------------------------------|
| 03/25/2024 | Smoke and temperature sensor integration | Push-button alarm modelling; Design Document | Flammable gas and temperature sensors integration |
| 04/01/2024 | Programming of current detector assembly | Final demo display box modelling; modification of previous model | Silent button testing |
| 04/08/2024 | Linkage commissioning between equipment | Modify models, order parts from Taobao | Building push button module |
| 04/15/2024 | PCB design and printing | Continue modifying the model and ordering parts; and assemble it | Connecting Audible and visual alarm with push button module |
| 04/22/2024 | Display module | Purchase of replacement parts based on assembly results | Display module |
| 04/29/2024 | Display module | Order aluminium and acrylic; assemble Demo Box | Display module |
| 05/06/2024 | Prepare Final Demo | Prepare Final Demo | Prepare Final Demo |

Table 7: Schedule Table

4 Ethics and Safety

Because our ESP8266 chip ultimately needs to rely on the software platform on the mobile terminal to link with the fire protection equipment we designed, the use of intelligent fire protection equipment and software may collect and transmit sensitive data, such as location information, environmental parameters, and so on. According to the IEEE Code of Ethics, #1[13], "to protect the privacy of others, and to disclose promptly factors that might endanger the public or the environment." The design process should ensure that the privacy of user data is protected from unauthorized access and data leakage, and that users are informed about how data is collected, used, and protected.

Regarding the new design of smoke alarms, push button alarms and audible and visual alarms, these products need to comply with the Chinese standard for self-contained smoke alarms: GB 20517-2006[14], which has provisions for high temperature and corrosion resistance, so polyvinyl chloride (PVC) material is used in the official products to meet the requirements and to facilitate the manufacture and reduce the cost.

Unfortunately, PVC is hazardous to the environment and is a difficult material to degrade. In order to meet the IEEE Code of Ethics, #1[13], "to hold paramount, the safety, health, and welfare of the public, to strive to comply with ethical design and sustainable We believe that equipment should be manufactured and used in a way that minimizes its impact on the environment. We believe that equipment should be manufactured and used in a way that minimizes its impact on the environment. For example, we need to use environmentally friendly materials and manufacturing processes for packaging, and modular designs that allow for easy disassembly and replacement of components, as well as ensuring that the equipment can be safely recycled at the end of its lifecycle.

According to our opinion and design, our products do not exist with race, religion, gender, disability, age, national origin, sexual orientation gender identity, or gender expression, which is mentioned in the IEEE Code of Ethics, #7[13]

References

- [1] J. Pritzker, “the 2022 annual report for the office of the illinois state fire marshal,” vol. 32, p. 31, Feb. 2023.
- [2] A. Cowlard, A. Bittern, C. Abecassis-Empis, and J. Torero, “Fire safety design for tall buildings,” *Procedia Engineering*, vol. 62, pp. 169–181, 2013.
- [3] J. Ma, W. Song, W. Tian, S. M. Lo, and G. Liao, “Experimental study on an ultra high-rise building evacuation in china,” *Safety science*, vol. 50, no. 8, pp. 1665–1674, 2012.
- [4] J. Nie and H. Du, “Overview of specialized smoke detector detection circuits,” , vol. 12, no. 06, pp. 39–41+46, 2012.
- [5] C. Feng, “Analysis of the causes of electric bicycle battery and charger fire,” *Firefighting Today*, vol. 4, no. 05, pp. 42–43, 2019.
- [6] General Administration of Quality Supervision, Inspection and Quarantine of the People’s Republic of China, Standardization Administration of the People’s Republic of China, “Self-contained smoke alarms:gb 20517-2006,” 2006. [Online]. Available: <http://c.gb688.cn/bzgk/gb/showGb?type=online&hcno=11BFFB6E7366D62926036872F2DEC1BA>
- [7] Ministry of Public Security of the People’s Republic of China, “Code for design of automatic fire alarm system:gb50116-2013,” 2013. [Online]. Available: https://js.119.gov.cn/202111/206aeb848d24575894f22639ff3e721_c_0535ace6ae86458fa1cf.html
- [8] Q. Tang, “Design and practice of smoke alarms supporting metro lora iot private networks,” *Internet of Things technology*, vol. 10, no. 07, pp. 12–15, 2020.
- [9] L. Jun, “Principles and applications of smoke alarms,” *Chinese security*, no. 22, p. 2, 2013.
- [10] X. Wang and X. Su, “Hall sensor-based current detection system,” *industrial and mining automation*, no. 02, pp. 74–76, 2008.
- [11] General Administration of Quality Supervision, Inspection and Quarantine of the People’s Republic of China, Standardization Administration of the People’s Republic of China, “Combustible gas detectors-part 1: Point-type combustible gas detectors for industrial and commercial use:gb 15322.1-2019,” 2019. [Online]. Available: <http://c.gb688.cn/bzgk/gb/showGb?type=online&hcno=1D7697EA12EA40F3886CA37C5592CC89>

- [12] General Administration of Quality Supervision, Inspection and Quarantine of the People's Republic of China, Standardization Administration of the People's Republic of China, "Manual fire call points:gb 19880-2005," 2005. [Online]. Available: <http://c.gb688.cn/bzgk/gb/showGb?type=online&hcno=4E298112C3B5DDFA5D13C32EC00B3063>
- [13] IEEE.org, "Ieee code of ethics," 2020. [Online]. Available: <https://www.ieee.org/content/dam/ieee-org/ieee/web/org/about/corporate/ieee-code-of-ethics.pdf>
- [14] General Administration of Quality Supervision, Inspection and Quarantine of the People's Republic of China, Standardization Administration of the People's Republic of China, "National standard of the people's republic of chinafire detection and alarm systems-smoke alarms," 2006. [Online]. Available: <https://openstd.samr.gov.cn/bzgk/gb/newGbInfo?hcno=11BFFB6E7366D62926036872F2DEC1BA>