

ME 470 / ECE 445: Senior Design Project

DESIGN DOCUMENT

Project Title

A Immersive Human-driven Robot in Detecting Foreign Matter in Tubes.

Team Members

Shixin Chen

Ziyuan Lin

Pengzhao Liu

Tianle Weng

Project Sponsor

Liangjin Yang

Teaching Assistant

Yutao Zhuang

Date

March. 24

1. Introduction

1.1 Problem

With the development of technology in the 21st century, systems like rockets, chemistry transportation systems, and systems underground are getting more likely to involve small and unreachable spaces for humans, for example, thin tubes which is used to transport chemical material. Sometimes, there could be foreign matter inside these tubes and pipes, and we need to figure out where these foreign objects are and even remove them. For such little space that is hard to reach and observe, human beings are getting harder to enter. Current solutions include self-control robots or robots controlled through remote handsets [1]. However, as the environment inside tubes could be very complex, these solutions could be either impossible or not flexible enough.

1.2 Solution

We will design a human-driven robot but in an immersive context. We will use a self-design electric car as a model. People change the speed through audio, changing the direction by manipulating the position of their hands as if there is a real steering wheel. This will be accomplished by a hand recognition neural network. The position of the car will be recorded and displayed on the screen in front of the driver or on the glass of the driver even though the actual car may be far away from the user. This will be implemented by a chip with a camera and WiFi module. In this way, the driver can immersively drive the car and make precise and subtle operations when the "road" condition is very complex. The robot is able to detect the foreign matter as a recognition or segmentation problem and send back the information, like the position of the foreign matter. Then humans can take corresponding actions.

1.3 Visual Aid

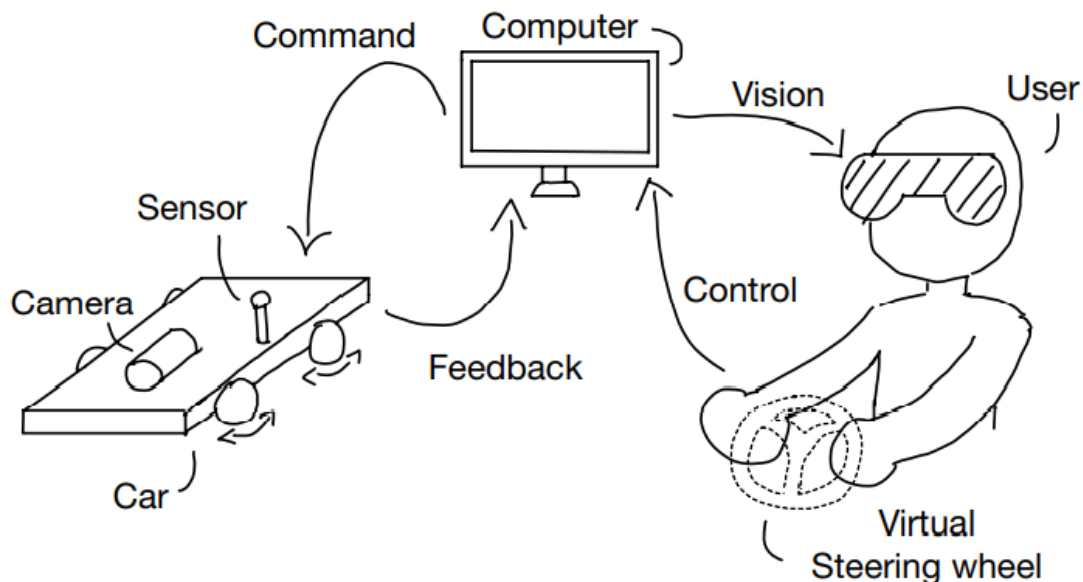

Figure 1: Visual Aid of the Project

1.4 High-level Requirements

- Our neural network algorithm can successfully recognize the position of the driver's hands in camera at least 95% recognition accuracy and determine which direction the car should turn.
- Our self-design remote control car should be able to move in different speed from 0 to 1m/s, make basic actions like turn right and left, move back and forth.
- To achieve the goal of immersive human-robot interaction, the car should be able to collect environment information to the driver by the camera it carried, and it can receive the action and audio command from driver and make responses in delay less than 100ms.

2. Design

2.1 Block Diagram

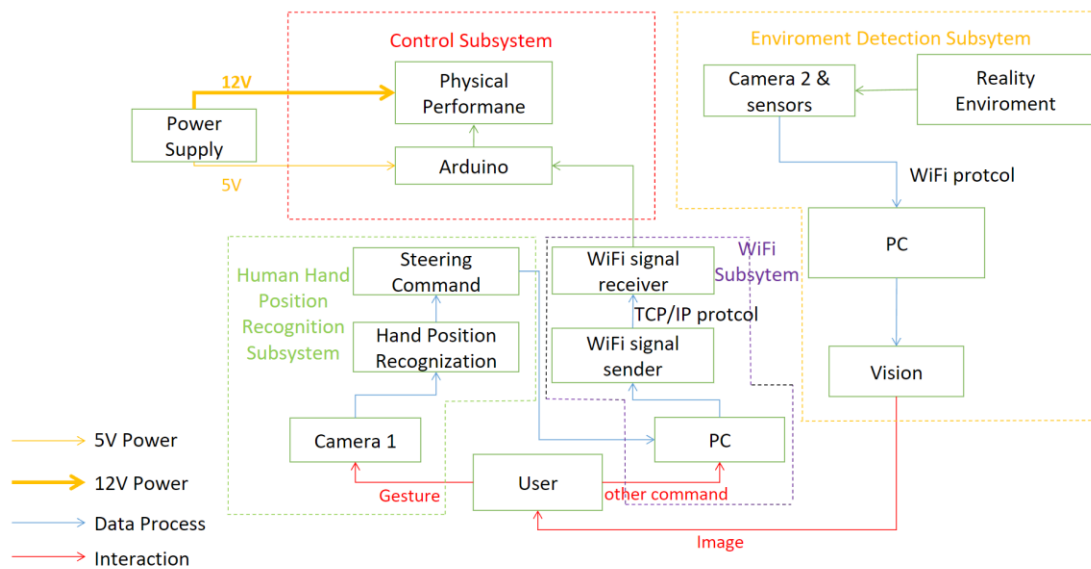

Figure 2: Block Diagram of the Project

Description: The Human Hand Position Recognition Subsystem is used to achieve the first high-level requirement of our project. It should be able to correctly detect hand position of the user. For the second part of our requirement, the control subsystem includes the robot body of the car and electrical part to make the car make actions and receive signals normally. And the environment detection subsystem should be able to accomplish the information collection task in the last requirement and all these subsystems are connected by internet protocol of based on our WiFi subsystem.

2.2 Physical Design

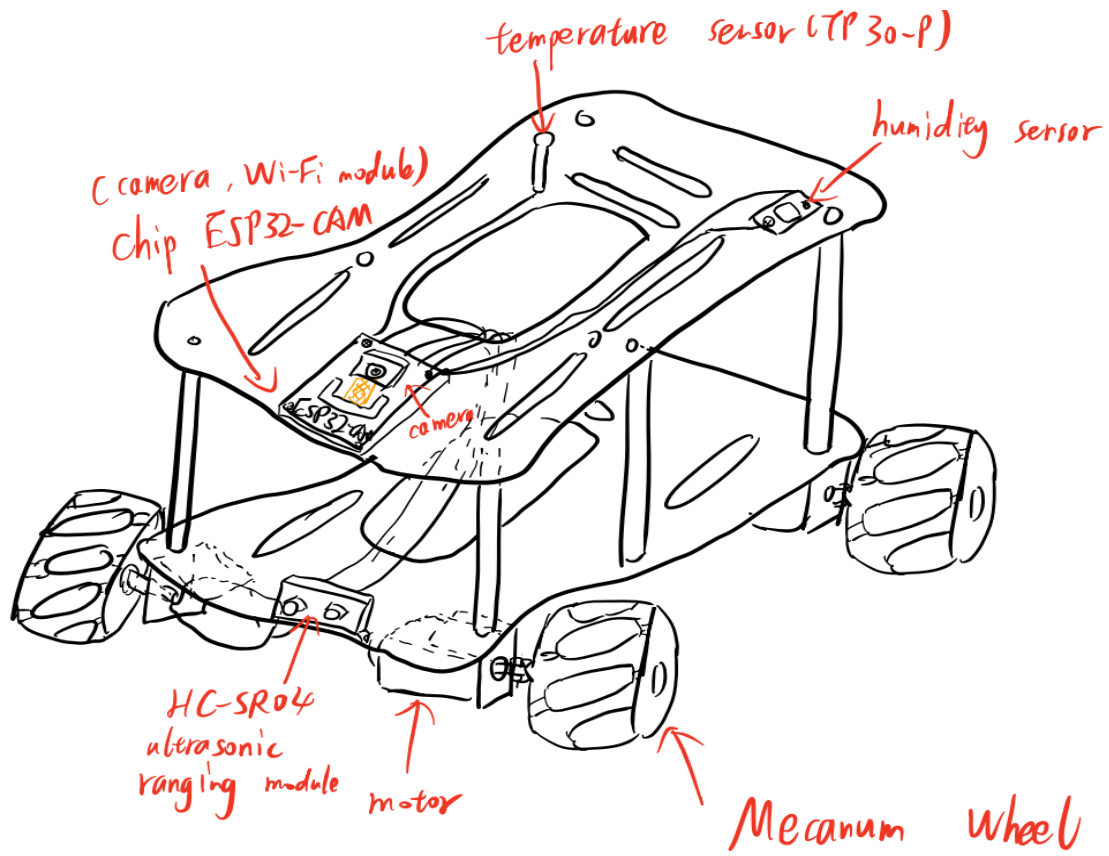

Figure 3: Physical Design

1.1 Subsystem

1.1.1 Human hand position recognition Subsystem

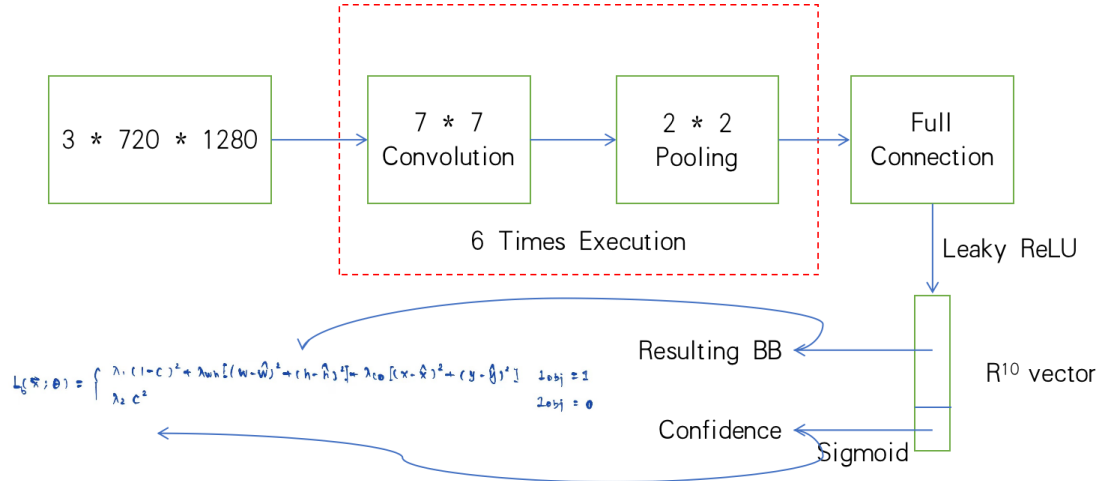

Figure 4: Network Design

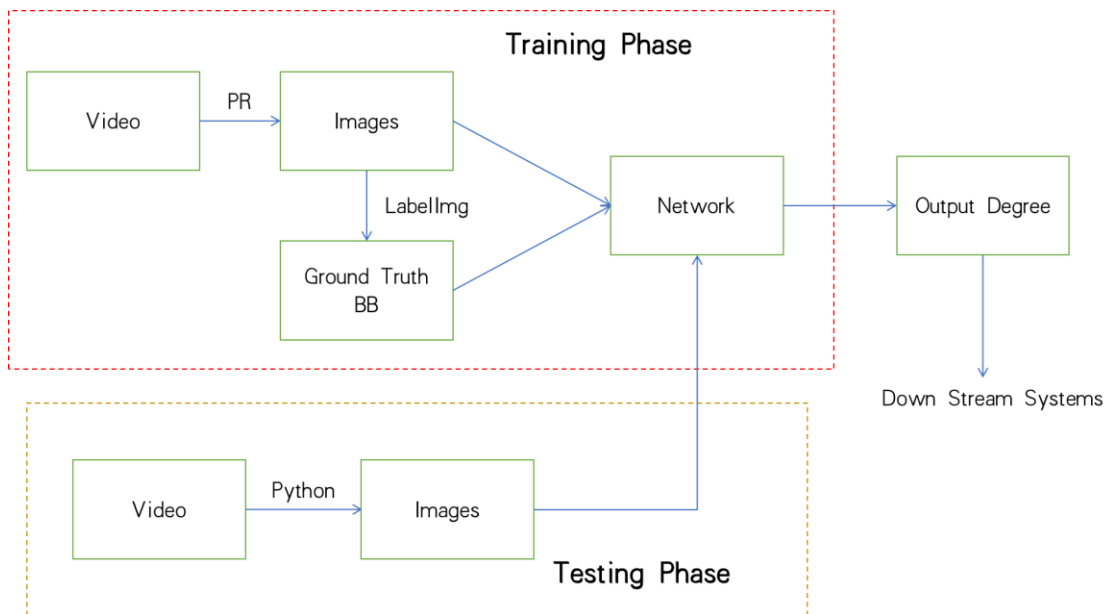

Figure 5: Human hand position recognition Subsystem Flow Chart

A human hand position recognition system based on YOLO-like [2] neural network for object detection task. This subsystem is the core component of our human-robot immersive interaction system. The user can use the normal driving position to remote control the car. The input is your hands' position pictures captured by the camera. After data processing, the output is the degree (from -90 to 90) you want to turn the wheel. The signal will be sent to the electronic component, which controls the direction of the wheel through wireless communication.

The input will be the real-time signal captured by the camera. We will build a YOLO-like [2] neural network for the object detection task. Since our task needs only one class, we do not need class dimensions. Consequently, we only need to output a five-dimensional vector: x, y, dx, dy, and confidence. Alternatively, we can try to re-formulate this task as a regression problem. In this case, we build an end-to-end network to output a single-degree value, and we can use the mean square error as our loss function. However, in order for the implementation of the algorithm to be fast enough to deal with real-time signals, we need to shrink the number of layers in the YOLO design to about 5-10 in this subsystem. The output will be passed to the WiFi to control the direction of the car.

Requirements	Verification
1. The object detection neural network should have smaller latency for each image compared with the frame rate of the camera.	1. The fast detection mode of yolo network of which our network is similar to dealing with real-time videos. The latency is less than 25 ms which ensures a frame rate of 40. The current frame rate reachable by our camera is less than 20. Hence valid.
2. The accuracy of our detection should be large enough that hands can almost always be captured in order to ensure the degree we get is accurate and changes smoothly.	2. YoLo can reach general correctness with 92.25% accuracy and 66.4 mAP with 20 classes. In our specific task, we only have 1 class and accuracy rate will be higher. We will slow down the detection rate(for example, half the rate with OR logic) to make error rate to $(7.75\%)^2$ which is smaller than 0.6%.

1.1.2 WiFi Subsystem

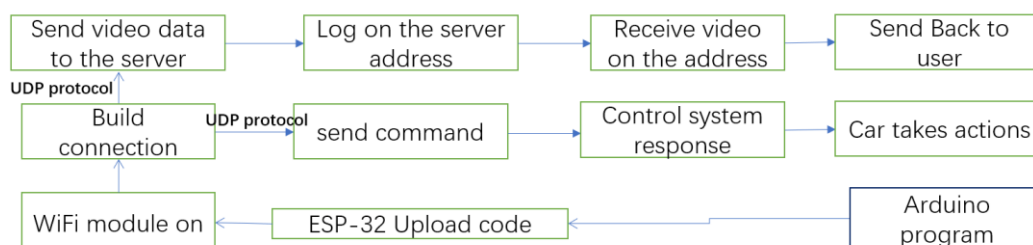

Figure 6: WiFi Subsystem flow chart

A WiFi transmission module. This subsystem serves as a bridge to connect the driver side and . We use WiFi instead of Bluetooth is because that it has faster transmission speed and wider range, which is suitable for video transmission. The subsystem will wrap environment information into message and use internet transmission protocol to send it to router, finally to the driver side. The driver side will send command signals in the same way back to the robot car. The signals will be sent to the electronic component, which controls the direction and the speed of the wheel through wireless communication.

Requirements	Verification
The robot should be equipped with a WiFi module to receive and send WiFi signals under regular internet protocol. It should support stable video transmission at low frame rate.	The WiFi module we have on ESP32 has advantages of small size, low power consumption, low heat generation, WiFi, network port transmission performance is stable. It supports UDP/IP protocol and has maximum PA output power 15dBm under 72.2 Mbps, maximum PA output power 20.5dBm under 11b mode.

1.1.3 Environment Detection Subsystem

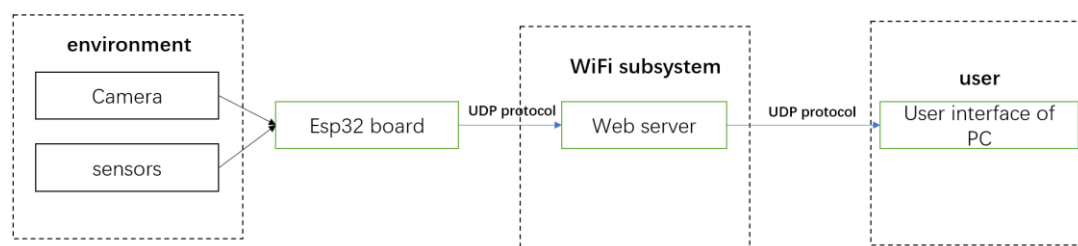

Figure 7: Environment Detection Subsystem flow chart

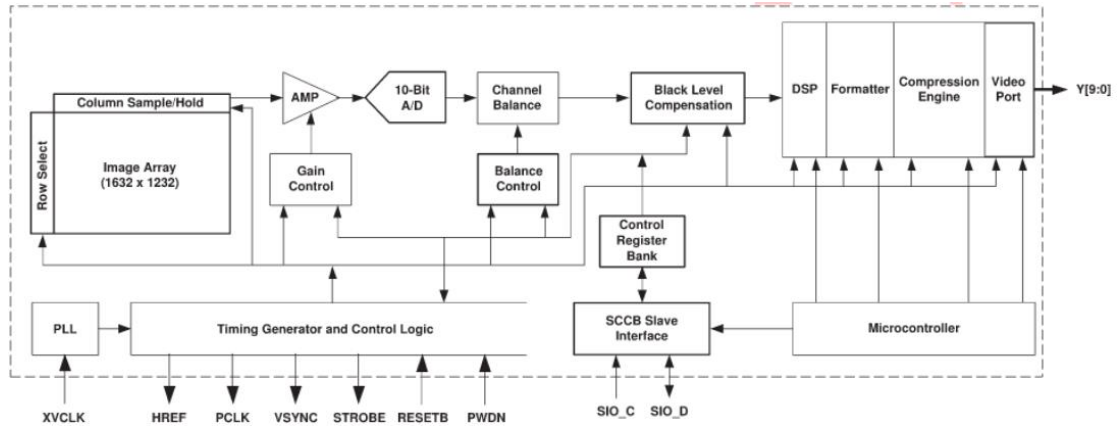

Figure 8: OV2640 camera function diagram

This subsystem is designed to collect the real environment information and give out the corresponding data set to other subsystems. We mainly use a camera to detect environments and maybe we will assemble several sensors to collect the environmental information of the workspace. For the control subsystem, we have a speed sensor and angular sensor to measure the velocity and orientation of the robot, then send them to the control system as the feedback; and quantify the information to display them on the human-robot immersive interface to help the user operate the system graphically and more intuitive. We also have the temperature and humidity sensor to check whether the workspace is suitable for our robot, so we can keep the robot from damage from the environment. We assume the ideal workspace is under 50 degrees Celsius and 40% humidity. Finally, we have the camera to take photos under a fixed time interval (like 10 photo per second), to make sure the recognition subsystem can make the decision as soon as possible. This system aims to collect real environment information, for example, recognize and find the foreign object inside the tube, by sensors and cameras. Then it will process the information data sent back to the computer.

Requirements	Verification
1.A SD camera with low power consumption that can work for a long time under normal environment and support high frame rate WiFi transmission.	1.The OV2640 Color CMOS UXGA(2.0 MegaPixel) Camera Chip with Omnipixel2 Technology we use can be activated and work normally at both 125mW and 140mW, It can also tolerate temperatures between 0°C to 50 °C . It has at most 1600*1200 definition, 60fps and can compress image for faster transmission.
2.Sensors that can measure other variables both about the car and the environment.	2. Tracking sensors like HC-SR04 Ultrasonic Sensor, temperature sensors like ds18b20. These sensors can

transform collected information into electric signal

1.1.4 Control Subsystem

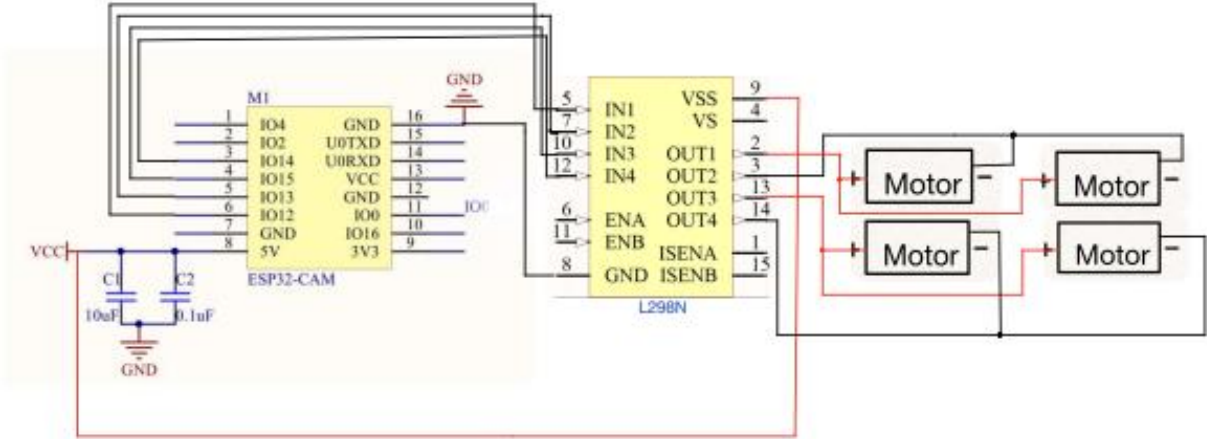

Figure 9: Control system schematic

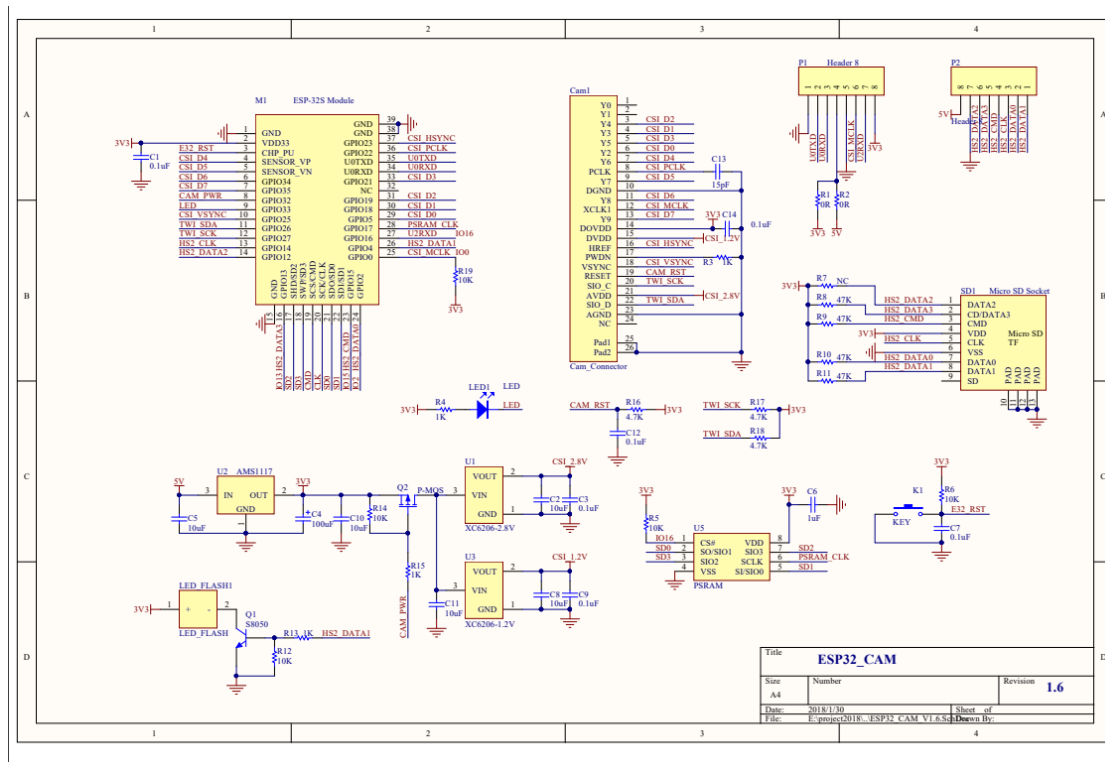

Figure 10: ESP-32 CAM schematic

This control subsystem includes the robot body of our remote-control car, which performs the main work of detecting. A car and electronic device (like Arduino) that can control the degree of the wheel and other operations. The system is also equipped with a WiFi receiver that receives the signal from the main computer. Speed-changing hardware (some voltage-changing circuit) on the car.

The main content of the physical performance is velocity and direction the car, which are both controlled by the motors and Mecanum wheels. The rated voltage of the motor is 12V and the rated current is 0.3A, the rated power should be less than 4W to avoid damage. The weight of each motor is around 150g and the rotate speed is 333 RPM. In order to improve the efficiency of car steering and reduce the complexity of control system, we decide to adopt Mecanum wheel with 65mm diameter. The Mecanum wheel is composed of the hub and the roller around the hub, The angle between the axis of the roller and the axis of the hub is 45 degrees, and there are two kinds of wheel A and B which are mirror images of each other. As we can see in figure X, τ is the torque applied to the wheel. when the wheel turns, it receives two perpendicular forces with same magnitude. The direction of force on a wheel also reverses as it moves forward and backward. We can change the direction of the resultant force on the car by controlling the direction of the four wheels, and finally control the direction of the car.

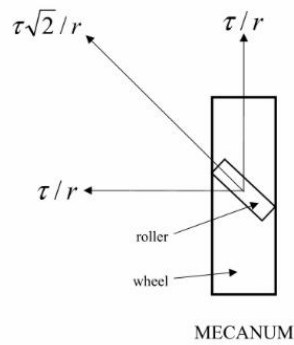

Figure 11: Force Analysis of Mecanum Wheel

Requirements	Verification
1. The car can operate normally in the working environment above 0 degrees Celsius (because water freezing below 0 degrees Celsius will inevitably lead to the skid of the car tires).	1. The ESP32 module is designed with four layers and operates in the temperature range of 40° C to 105° C. It has been approved by FCC, CE-RED, SRRC, IC, KCC, and TELEC for a wide range of commercial applications.
2. The deflection Angle of the car should be less than 10 degrees when it runs in a straight line.	2. We define 2 kinds of skid which are axial skid error and radial skid error. After the prototype assembly is completed, we will make the car run different straight-line distances at different speeds, combine the data under, and calculate the error. The calculated error ratio will be factored into the dynamic equation to compensate for the error.

2.4 Tolerance Analysis

2.4.1 Mecanum Wheel

As we mentioned before, the Mecanum wheel is an omnidirectional wheel design for a land-based vehicle to move in any direction. We can arrange different kinds of wheel motions to move vehicle in almost any direction with any rotation. Due to the fact that axis of the roller and the axis of the hub formed a 45-degree angle, resulting in the Mecanum wheel in the process of rotation will produce a small roll axial force in the axis direction. However, when the car is moving in a real environment because the ground is not flat, and the speed between the motors will be slightly different, we cannot guarantee that the four wheels can be perfectly matched. Therefore, we will mainly derive the kinematic equation of the car in straight motion. In the future, we will use the experimental data to improve the equation we derived.

Before start, several reasonable assumptions should be made to simplify our calculation.: (1) The four wheels of the car is on the ground at the same time and there is no relative sliding between the ground and the car. (2) The center of gravity of the car body coincides with the geometric center. (3) The Mecanum wheel and the frame of the car are rigid.

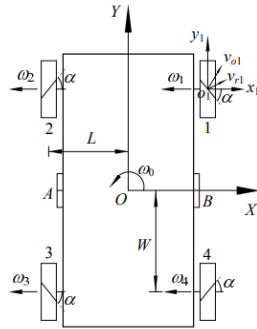

Figure 12: Diagram of Car Motion

According to figure X, we take the wheel center o1 as the origin, establish the coordinate system o₁-x₁y₁, assuming the axis motion speed of wheel group 1 is V_{o1}, then we get:

$$V_{o1} = \begin{bmatrix} 0 & \sin \alpha \\ R & \cos \alpha \end{bmatrix} \begin{bmatrix} \omega_1 \\ V_{r1} \end{bmatrix} = \begin{bmatrix} 1 & 0 & -W \\ 0 & 1 & L \end{bmatrix} \begin{bmatrix} V_X \\ V_Y \\ \omega_o \end{bmatrix}$$

(1-1)

R: Diameter of the wheel

W: Half the distance between front and rear wheel centers

L: Half the distance between right and left wheel centers

V_X: Velocity of the center of the car in the X direction in the coordinate system O-XY

V_Y: Velocity of the center of the car in the Y direction in the coordinate system O-XY

ω_o: Angular velocity of rotation of the car in the coordinate system O-XY

For our robot car, α is 45 degree so tan α is 1. Similarly, we generalize the equation (1-1) to the other three wheels to obtain the kinematics equation of the car:

$$\begin{bmatrix} \omega_1 \\ \omega_2 \\ \omega_3 \\ \omega_4 \end{bmatrix} = \frac{1}{R} \begin{bmatrix} -1 & 1 & W+L \\ 1 & 1 & -(W+L) \\ -1 & 1 & -(W+L) \\ 1 & 1 & W+L \end{bmatrix} \begin{bmatrix} V_X \\ V_Y \\ \omega_o \end{bmatrix}$$

(1-2)

As can be seen from equation (1-2), when the translation velocity and rotational

angular velocity of our robot car are known, we can calculate the angular velocity of each Mecanum wheel; Similarly, if we know the angular velocity of each Mecanum wheel, we can also find the the translational velocity and the rotational angular velocity of the car. For our design, R is 32.5mm, W is 80mm and L is 81mm.

In our future test, we define 2 kinds of error: axial skid and radial skid. We can run the car a certain distance in a straight line, for example, ten meters, and then measure the error of horizontal and vertical displacement. Based on the measurement, we can calculate axial error and radial error:

$$\delta_{axi} = \frac{|S_x - S'_x|}{S_y}$$

Axial error:

$$\delta_{rad} = \frac{|S_y - S'_y|}{S_x}$$

Radial error:

S_x and S_y are the theoretical distance in x and y direction, S'_x and S'_y are the real distance in x and y direction. We can apply them in equation (1-2) to get our real kinematic equation:

$$V_Y = \frac{4}{R} [\omega_1(1 - \delta_{rad1}) + \omega_2(1 - \delta_{rad2}) + \omega_3(1 - \delta_{rad3}) + \omega_4(1 - \delta_{rad4})]$$

$$V_X = \frac{4}{R} [-\omega_1(1 - \delta_{rad1}) + \omega_2(1 - \delta_{rad2}) - \omega_3(1 - \delta_{rad3}) + \omega_4(1 - \delta_{rad4})]$$

$$+ \frac{4}{R} \cdot \delta_{axi} [\omega_1(1 - \delta_{rad1}) + \omega_2(1 - \delta_{rad2}) + \omega_3(1 - \delta_{rad3}) + \omega_4(1 - \delta_{rad4})]$$

(1-3)

With the help of equation, we can increase the accuracy of our control system and decrease the error during motion. We should test the error with different speed and obtain a linear relationship between error and velocity. Typically, according to our estimation, error can be ignored if the axial skid error is smaller than 0.05, which is roughly corresponding to 3 degree rotation. Radial skid error actually almost does not have effect on the straight line motion of the car.

2.4.2 Qualitative Analysis of software implementation

The real-time analysis of the hand recognition requires a fast processing of the video. The neural network requires a huge computing power. We believe that we can deal with this. The YOLO design has a real-time version, and we decide even to shrink the size of the network. The GPU implementation will make sure that the computation will be parallelized. FPGA board or Arduino board cannot be put on the car. As our car should be implemented in small space, we need to make our control system small enough. Instead of FPGA board or Arduino board, we will use MCU. The size of MCU is relatively small so that we can fit it on our car.

3. Costs and schedule

3.1 Costs Analysis

3.1.1 Labor

For each member in our group, we spent about 10 hours per week on this project. And we scheduled to finish this project in 3 months (15 weeks). We estimate our salary per hour as ¥100/hour and we believe that everyone should be paid the same wage for the same level of work they put in.

Name	Hourly Rate	Hours	Total	Total×2.5
Shixin Chen	¥100	150	¥15000	¥37500
Ziyuan Lin	¥100	150	¥15000	¥37500
Pengzhao Liu	¥100	150	¥15000	¥37500
Tianle Weng	¥100	150	¥15000	¥37500
Total				¥150000

3.1.2 Parts

item	Cost(in total)	Cost(bulk)	explanation
Google Colab VIP membership	¥280	¥70	Online GPU leasing Fees
battery	¥8	¥8	
Frame of car& motors	¥429		Include Macnum wheels
L298N Motor Driver Board	¥7.5	¥7.5	
Esp32-CAM chip + OV2640 camera	¥75	¥37.5	
Dupont Line	¥6.6	¥3.3	
Resistors	¥2.1	¥2.1	
Battery box	¥3	¥3	
HC-SR04 distance sensor	¥4.8	¥4.8	

3.1.3 Sum of costs into a grand total

$$280+8+429+7.5+75+6.6+2.1+3+4.8 = ¥816$$

3.2 Schedule

Week	Ziyuan Lin	Shixin Chen	Tianle Weng	Pengzhao Liu
3/13/2023	Design neural network for hand recognition/ Create and label datasets	Investigate voice recognition/ Create and label datasets	Create and label datasets/ Purchase of related equipment	Create and label datasets/ Purchase of related equipment
3/20/2023	Design neural network for hand recognition/ Create and label datasets	Buy chips and related equipment, Investigate esp32-CAM board	Assemble car, test the basic mechanical performance of the car	Assemble car, test the basic mechanical performance of the car
3/27/2023	Train and finetune the neural network of hand-recognition and enhance its robustness	Adapt ESP32-CAM on the Development Environment in Arduino and achieve smooth video transmission	Do tolerance analysis, determine the kinematic equation to test error	Help Shixin to adapt the ESP32-CAM, and figure out the simulated connection of the chip and the car.
4/3/2023	Implement the well-trained network of hand-recognition	Connect the chip to the car and implement all two-way information transmission	Calculate the transfer function used for controlling Mecanum wheel	Cooperate with Shixin to install the chip to the car, also connect the motor and other sensor.
4/10/2023	Investigate recognition algorithm camera video of the car	Investigate recognition algorithm camera video of the car	Test the physical performance of the Mecanum wheel on uneven ground	Test the functionality of all camera and sensors to make sure they can work during the motion of the car.
4/17/2023	Find proper dataset and proper network type to train the neural network	Find proper dataset and proper network type to train the neural network	Write the controlling program for the car on the chip to achieve our requirement.	Write the controlling program for the car on the chip to achieve our requirement.

4/24/2023	Implement the well-trained network of object detection	Implement the well-trained network of object detection	Test the prototype's performance when driving in a straight line to improve dynamic equation	Start to leverage the recognition subsystem to control the car.
5/1/2023	Improve user interface	Improve user interface	Improve the dynamic equation	Improve user interface
5/8/2023	Write the report	Write the report	Write the report	Write the report
5/15/2023	Prepare the final presentation	Prepare the final presentation	Prepare the final presentation	Prepare the final presentation

4. Discussion of Ethics and Safety

4.1 Ethics

Under the guidance of the first part IEEE Code of Ethics, we are clear that in professional activities, we need to improve the understanding by individuals and society of the capabilities of conventional and emerging technologies [3], including intelligent systems. Thus, we are responsible for teaching our product users how to use our products and technology correctly. We would explain by demo video or a simple and easy-to-understand user manual.

Also, according to the first part of the IEEE code of Ethics, we need to protect the privacy of people [3]. Since our project includes video transmission, we will make sure the video information we use will not be spread or stored for illegal use.

What's more, according to the fifth part of IEEE code of Ethics, we should "seek, accept, and offer honest criticism of technical work, to acknowledge and correct errors". Thus, if we find the drawbacks of our project, we will keep modifying and improving it and receiving criticism with an open mind.

4.2 Safety

For the safety of users, according to the first part of the IEEE code of Ethics, we need to protect the safety, welfare, and health of the public [3]. To maintain safety, we promise our assembled vehicles are in small size, and their fastest speed is limited so that it does not have the danger of driving out of control. Also, it will not be equipped with dangerous tools which can hurt people. Privacy safety was talked about before in the 3.1 session.

For code safety, we will not apply others' codes without permission and reference. At the same time, we will keep our original code private and make sure others can only use our code by formal request.

At last, for experiment safety, according to the first part of the IEEE code of Ethics, "to maintain and improve our technical competence by training or experience [3]." We will also follow the safety guidelines during our project. We will obey lab rules, such as at least two people are needed to do experiments in the lab and follow the rule of safe battery usage [4]. Under the guidance of assisting teachers, we will build the hardware of our remote control vehicles correctly and safely.

5. Citations

[1] Kamegawa, Tetsushi, et al. "Development of the snake-like rescue robot" kohga". IEEE International Conference on Robotics and Automation, 2004. Proceedings. ICRA'04. 2004. Vol. 5. IEEE, 2004. [Accessed: 08-Mar-2023].

[2] Redmon, Joseph, et al. "You only look once: Unified, real-time object detection." Proceedings of the IEEE conference on computer vision and pattern recognition. 2016. [Accessed: 07-Mar-2023].

[3] Ieee.org, "IEEE Code of Ethics", 2020. [Online]. Available: <http://www.ieee.org/about/corporate/governance/p7-8.html>. [Accessed: 07-Mar-2023].

[4] "Safe Practice for Lead Acid and Lithium Batteries," University of Illinois ECE445 Course Staff, 2016. [Online]. Available: <https://courses.engr.illinois.edu/ece445zjui/documents/GeneralBatterySafety.pdf>. [Accessed: 07-Mar-2023].