

ECE 445
Spring 2025

Project #84

Mobile Stray Cat Rescue Station

Team Members:

Ming Yi(myi22)

Yilin Tan(ytan47)

Frank Chen(sihan6)

Professor and TA:

Michael Oelze

Rui Gong

- 1. Introduction.....3**
 - 1.1. Problem.....3
 - 1.2. Solution.....3
 - 1.3. Visual Aid:.....4
 - 1.4. High-Level requirements list.....4

- 2. Design.....6**
 - 2.1. Block Diagram:..... 6
 - 2.2. Physical Design:..... 6
 - 2.3. Subsystem Overview..... 7
 - 2.3.1. Power Supply Module..... 7
 - 2.3.2. Heating module..... 9
 - 2.3.3. Main Control Module.....11
 - 2.3.4. Shell and Insulation Layer..... 12
 - 2.4. Tolerance Analysis..... 13
 - Tolerance Considerations..... 14

- 3. Cost and Schedule.....15**
 - 3.1. Cost Analysis..... 15
 - 3.2. Schedule:..... 16

- 4. Ethics and Safety.....18**

- 5. References.....20**

1. Introduction

1.1. Problem

Stray animals, particularly cats, continue to face challenges in urban and suburban environments. While many animal welfare organizations and individuals work to provide care, not all stray cats receive consistent food and shelter. Exposure to extreme temperatures, especially in winter, can be fatal. Studies have shown that **hypothermia in stray cats can occur at temperatures below 10°C (50°F), significantly increasing their mortality rate** (Smith et al., 2019). In many neighborhoods, including our own, it is common to see stray cats struggling to find food and warmth. When individuals attempt to help, they may not always have food available or a proper way to provide ongoing assistance. Even if food is provided at one instance, it does not ensure continuous support for these animals.

1.2. Solution

To address this problem, we propose the Mobile Stray Cat Rescue Station—a portable, solar-powered shelter equipped with an AI-based feeding and heating system. This device is designed to automatically provide warmth and food to stray cats based on environmental conditions and real-time cat detection. Unlike traditional feeding stations, our system integrates AI image recognition to ensure that only stray cats trigger food dispensing and heating activation, reducing waste and preventing unintended use by other animals. **Studies indicate that AI-driven animal identification systems can achieve over 90% accuracy in distinguishing between different species** (Zhang et al., 2021), making it a reliable method for targeted assistance. Through a remote monitoring system, maintenance personnel can efficiently manage multiple stations and provide refills when necessary. This approach significantly enhances the survival rate of stray cats in extreme weather conditions while minimizing human intervention.

1.3. Visual Aid:

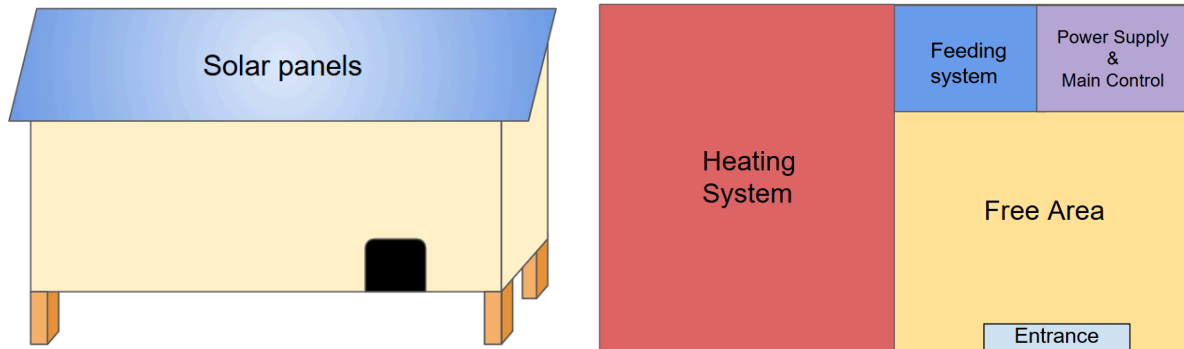

Figure 1: Overall and simplified design diagram

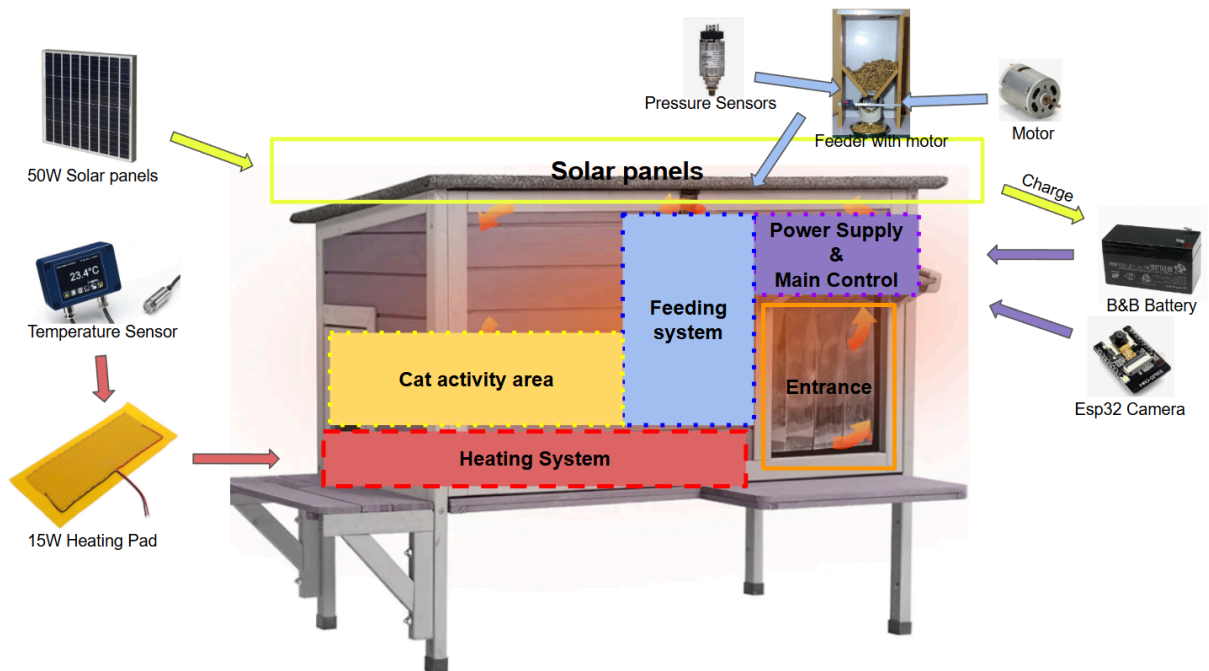

Figure 2: Detailed design drawing of each component

1.4. High-Level requirements list

- The heating system must activate only when a cat is detected and when the ambient temperature falls below a predefined threshold. It should respond within 10 seconds and maintain a temperature range between 10°C and 25°C inside the station.
- The feeding system must dispense food only when a cat is detected, ensuring that the error in the amount of food dispensed is less than 10% per activation.

- The AI-based detection system must correctly identify a cat with at least 90% accuracy, ensuring a response time of 10 seconds or less from detection to system activation.
- The power system must support continuous operation via solar energy, ensuring that the system can function for at least 8 hours without sunlight, maintaining critical functions such as AI detection, heating, and food dispensing.

2. Design

2.1. Block Diagram:

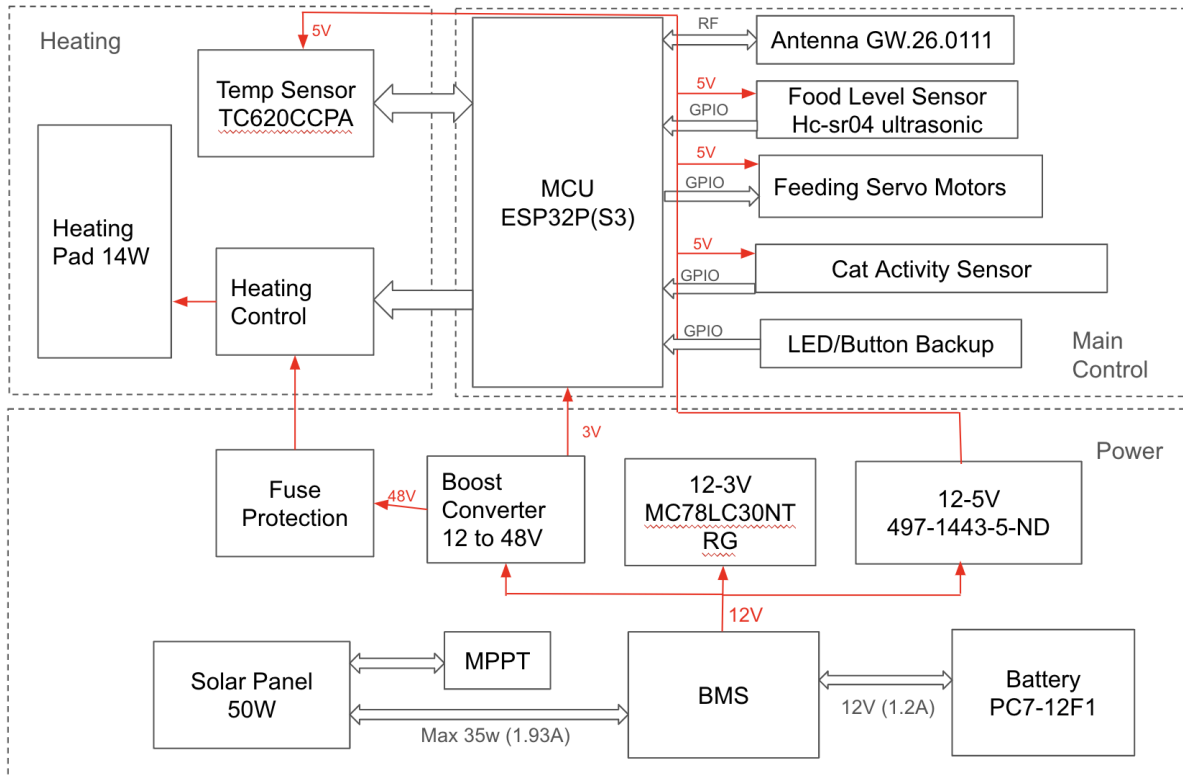

2.2. Physical Design:

The physical design of this is based on **Figure 2**. The exterior is just built of wood, and layered with insulated foam insulation tape. This allows the station to be constantly staying warm with the heating from the heating system. The main part of heating is done with the heating pad, and other than that it would be the feeding system. Inside the feeding system, we have a weight sensor to detect the weight of the food inside the bowl. If it falls below a rate of 20 percent, we would then add more food to it. The main power supply of this is done by solar panel, along with a battery for night usage. Inside there is also a ESP32-Camera and a temperature sensor is used to detect the cat.

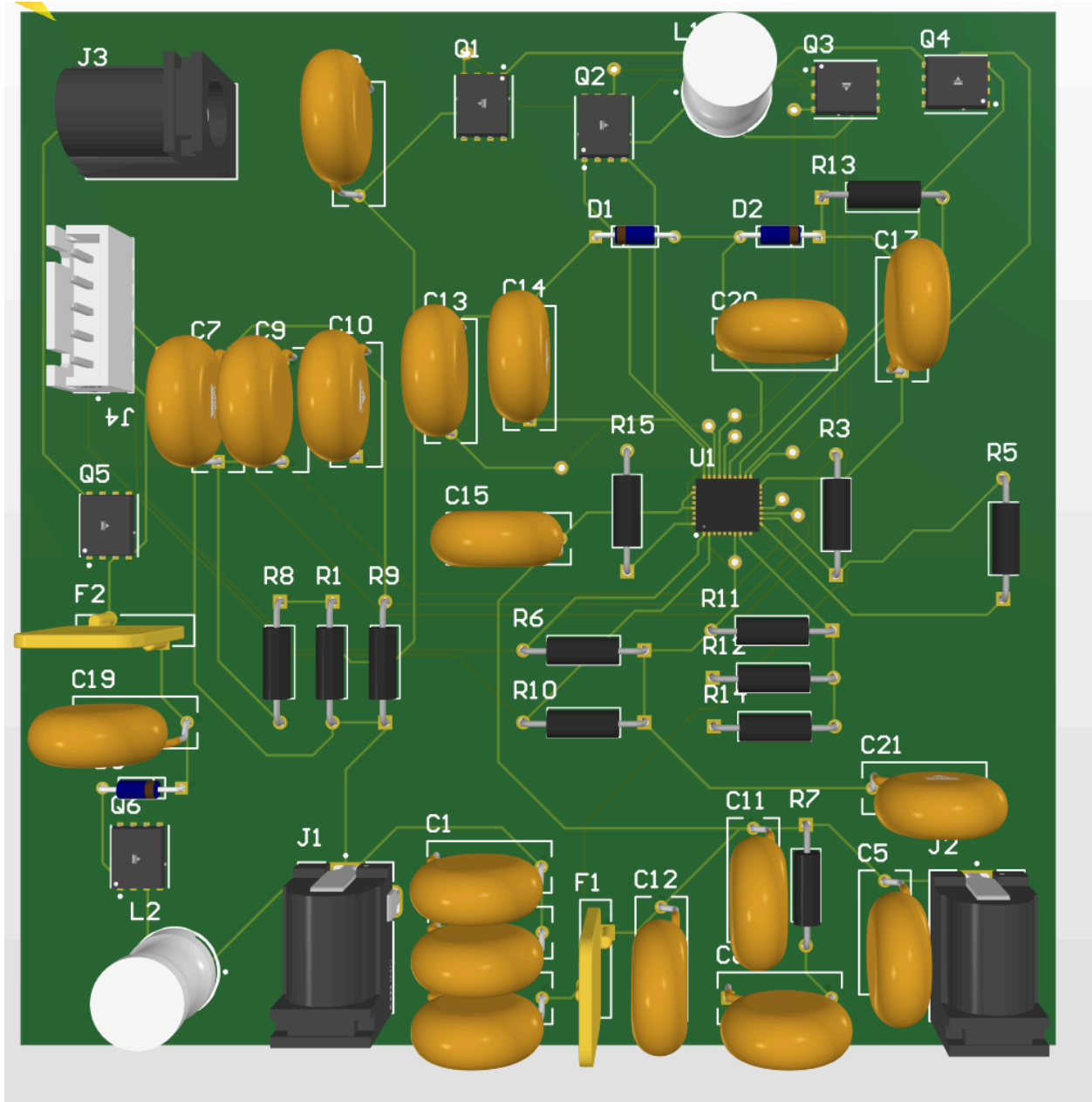

BMS PCB CAD Design

Key Components & Design:

1. Power Generation

- Solar Panel: A panel in the 20–50 W range is recommended to balance efficiency and size constraints. For example, a 35 W or similar power panel from Tycon

Systems could be used
([Digikey TPS-12-35W](#)).

- Charging/Discharge Control: Uses a Battery Management System (BMS) to handle maximum power point tracking (if implemented), improve charging efficiency, and prevent overcharging or deep discharging.

2. Power Storage

- Secondary Lithium Battery Pack: Chosen for rechargeability and longevity. For instance, a battery rated 12 V nominal (or higher if the design calls for 3 or 4 cells in series) can be used with a capacity of 1–2 Ah or more, depending on heating and load requirements
([B&B Battery BP1.2-12](#) as a sample reference).
- Protection Circuit: The BMS (and associated sensors) continually monitors battery voltage/current/temperature to maintain healthy battery operation.

3. Voltage Regulation

- Buck-Boost Converters: Provide stable output rails for different subsystems:
 - 3.3 V or 5 V for the microcontroller, sensors, and motor driver logic.
 - 12 V (or direct battery voltage) for the heating pad, depending on design.
- Fuse/Overcurrent Protection: Recommended on both the battery pack output and solar input lines to guard against short circuits or high current faults.

Why It Matters:

- Ensures reliable off-grid power so the station can function autonomously, including powering the heating module at night.
- Protects the battery from unsafe conditions (overvoltage, undervoltage, etc.).

2.3.2. Heating module

Overview:

This subsystem provides warmth inside the enclosure and automatically regulates temperature via sensors and a simple control loop (on/off or PID).

Key Components & Design:

1. Heating Method

- Heating Element: Carbon fiber wires or resistive heating pads. A ~15–20 W element is typical, balancing power draw with heating effectiveness (Example: Walbest 20 W Reptile Heating Pad).
- Placement: Under the enclosure floor or along sidewalls, with fire-resistant insulation beneath.

2. Power Consumption & Safety

- Power Draw: ~15 W ensures moderate current draw from the battery and is still able to raise temperatures effectively in a small enclosed space.
- Thermal Safety Features:
 - Fire-resistant insulation around the pad.
 - Thermal cutoff switch or thermostat to prevent overheating.

3. Temperature Control

- Temperature Sensor: An onboard thermistor or humidity/temperature sensor (e.g., DHT22, DS18B20, etc.) for real-time feedback.
- Control Logic:
 - Heater activates below 10 °C (50 °F).
 - Heater turns off above 25 °C (77 °F).
- MCU Interface: The main control module (Subsystem 3) reads the sensor and drives the heater MOSFET switch (or relay) accordingly.

Why It Matters:

- Provides vital warmth for cats in cold weather.
 - Minimizes battery usage by only running the heater when needed.
-

2.3.3. Main Control Module

Overview:

This module is the “brain” of the station. It collects sensor data, controls the feeder and heater, manages power usage, and communicates status information (e.g. via Wi-Fi).

Key Components & Design:

1. Microcontroller

- An ESP32 (for built-in Wi-Fi/Bluetooth) or an STM32 MCU with a dedicated Wi-Fi module. The ESP32 is popular for its Wi-Fi stack and low-power modes.
- Low-Power Modes: The MCU can sleep when idle, waking only to read sensors or transmit data.

2. Wi-Fi Transmission

- The controller can send data (e.g., temperature, battery level) to a remote server or local network. If no network is available, a hotspot mode can allow a phone or laptop to connect locally.

3. Feeding System Control

- Ultrasonic Sensor: Monitors the hopper or bowl level; if food is low, the MCU triggers a feeder motor to dispense more.
- Motor Driver: A small DC gearmotor or servo is powered and managed by the MCU (via a transistor or H-bridge).

4. Power Monitoring

- The MCU continuously reads the battery voltage/current from the BMS or an ADC input to gauge remaining capacity and optimize usage (e.g., reduce heater usage if battery is critically low).

5. Cat Activity Monitoring (Optional)

- A small camera can capture images and send them to the cloud for AI-based detection of cats, ensuring only cats (not raccoons or other animals) are using the station.

Why It Matters:

- Orchestrates all station functions (heating, feeding, power management).
 - Provides remote visibility into shelter status (temperature, battery, cat activity).
-

2.3.4. Shell and Insulation Layer

Overview:

This subsystem provides mechanical protection, water resistance, and insulation to reduce heat loss, thus enhancing the effectiveness of the heating system.

Key Components & Design:

1. Shell Construction

- Materials: Waterproof plastic boards, aluminum, or robust 3D-printed components.
- Elevation: A frame or legs raise the shelter ~10 cm above the ground to avoid water intrusion during rain.

2. Insulation

- Fireproof Foam Boards or similar insulating panels line the interior.
- Keeps the enclosure warm and reduces required heating power.

3. Weatherproofing & Ventilation

- Sealed seams or gaskets to prevent leaks.
- Minimal but adequate vent holes to prevent condensation build-up.
- A cat flap or small doorway for easy feline entry while blocking drafts.

Why It Matters:

- Conserves energy by minimizing heat loss.
 - Protects electronics (power module, MCU) from rain, snow, and debris.
-

Overall Interactions

1. Subsystem 1 (Power) continuously collects solar energy and charges the battery via a BMS. It provides stable DC voltages to all other subsystems. Also the BMS control IC communicates settings with Subsystem 3 (I2C).
2. Subsystem 2 (Heating) draws power from Subsystem 1, with on/off commands from the main controller in Subsystem 3.
3. Subsystem 3 (Main Control) collects sensor data (temperature, food levels, battery status) and orchestrates heating and feeding. It also handles communication via Wi-Fi.
4. Subsystem 4 (Shell & Insulation) ensures environmental protection and reduces the heat load, improving the overall efficiency of Subsystems 1 and 2.

2.4. Tolerance Analysis

Overall Power Demand

The power system of the mobile stray cat rescue station relies on a solar panel and a rechargeable battery pack to ensure continuous operation. The critical aspect is to ensure the system has sufficient power generation and storage to sustain functionality.

For a simple power consumption calculator:

Subsystem	Estimated Power
Heating	15W (intermittent)
MCU/Sensors	2W (intermittent)
Camera Module	3W
Food dispensing	5W (intermittent)
WiFi	2W
Total Estimated	~ 20W for heating

Solar Panel Generation: The efficiency of solar panels depends on multiple factors, but assuming a 35W solar panel with an efficiency of 20%, a 5 hour charging will generate 31.5Wh energy everyday.

Battery Storage and Capacity: For a 12V, 10Ah battery, it can support around 5.5 hours heating.

Tolerance Considerations

- Solar Panel Output Variability:
 - Under cloudy conditions, solar power generation may drop by 50% or more. This means the daily power generation could fall to 15Wh/day.
 - A larger panel (50W) or multiple panels would mitigate this risk.
- Battery Efficiency and Degradation:
 - Lithium batteries degrade over time. Typically, their capacity reduces by 20% after 500 charge cycles.
 - To compensate, a larger battery pack (e.g., 15Ah instead of 10Ah) may be required.
- Power Consumption Variation:
 - Peak power draw (e.g., when heating and food dispensing occur simultaneously) could exceed 25W.
 - A higher capacity battery or power management techniques (e.g., prioritizing heating over feeding when battery is low) can help maintain efficiency.
- Temperature Effects:
 - Lithium-ion batteries lose efficiency in cold conditions. At -10°C, efficiency can drop by 30%.
 - Insulation and heating elements powered by excess solar energy can help mitigate this issue.

So this means we need to actively design a heating system to open/close the heating pad and save energy.

3. Cost and Schedule

3.1. Cost Analysis

The most expensive part of this project would be the solar panel, and the exterior of the rescue station. Building the house would also take a while, therefore we estimated about 40 hours of work per person for this project(This includes everything else as well, such as software development, and connecting all the subsystems together).. That would be about \$3,000 each, with a reasonable pay of \$30 per hour.

Labor Cost:

$$\$30 \times 2.5 \times 40 = \$ 3000$$

$$\text{-Total labor} = \$ 9,000$$

Parts and Cost:

Description of parts	Part #	Quantity	Cost
Solar panel used for power supply + Battery (Purchase from ebay)		1	\$ 40.99
ESP32	1965-ESP32-S3-DEVKI TC-1U-N8R8-ND	1	\$ 13.3
Thermal Sensor	TC620CCPA-ND	1	\$ 1.86
Weight Sensor (Amazon)		1	\$ 5.89
Heating Pad (Walmart)		1	\$9.6
ESP32 Camera	3647-26387-ND	1	\$11.38

Foam Insulation Tape (HomeDepot)		1 roll	\$15.98
Wood(To build the exterior) 1/4"-thick, 2-ft. square		4	\$25.44

Parts Total: \$ 124.44

Grand Total: \$ 9000 + \$124.44 = 9124.44

3.2. Schedule:

3/3-3/9	<ul style="list-style-type: none"> ● Complete PCB for first round review - Everyone ● Work on the breadboard - EVERYONE
3/10-3/16	<ul style="list-style-type: none"> ● Complete the breadboard - EVERYONE ● Purchase all materials - EVERYONE
3/17 - 3/23	<ul style="list-style-type: none"> ● Build the exterior- Ming ● Start working on software side - Ming/Yilin ● Work on the second PCB- Frank
3/24 - 3/30	<ul style="list-style-type: none"> ● Assemble solar panel - Ming ● Assemble other part - Yilin, Frank ● Image Processing - Ming, Yilin
3/31 - 4/6	<ul style="list-style-type: none"> ● Submit the second pcb to the Third Round PCBWay - EVERYONE
4/6 - 4/13	<ul style="list-style-type: none"> ● Start placing all parts inside the rescue

	station. - EVERYONE
4/14 - 4/20	<ul style="list-style-type: none">● Finish up the project, detect if there's any bug with software / hardware- EVERYONE● Prepare for Mock Demo - EVERYONE
4/21 - 4/28	<ul style="list-style-type: none">● Double check on all parts, software and hardware, and be ready for a mock demo. - EVERYONE

4. Ethics and Safety

1.1. Usage of Solar Panel

1.1.1. Since we are using a solar panel for the main purpose of power supply, we should keep in mind the precautions of a solar panel, such as electrical safety, mounting and structural precautions, positioning and shading, and cleaning and maintenance.

1.1.1.1. Electrical Safety

1.1.1.1.1. Make sure that power is turned off before maintenance, since solar panels can generate significant voltage in sunlight.

1.1.1.1.2. Usage of gloves that isolates electricity, insulated tools, and safety glasses

1.1.1.1.3. Making sure all wiring connections are secure and that hot components are taken care of before repairing.

1.1.1.2. Mounting and Structural Precautions

1.1.1.2.1. Making sure the ground mount is strong enough to handle the weight of solar panels, and that it doesn't get destroyed by the local wind and weather conditions.

1.1.1.2.2. Avoiding dangerous contact with the solar panel, such as stepping and cracking it.

1.1.1.3. Positioning and Shading

1.1.1.3.1. Properly positioning the solar panel, and making sure the tilt angle is orientated correctly to obtain sunlight and transform that into power.

1.1.1.3.2. Minimize shading to obtain the most amount of sunlight as possible, since even a small shaded area can cause significant reduction of the panels power output.

1.1.1.4. Cleaning and Maintenance

1.1.1.4.1. Scheduling regular maintenance to make sure that the solar panel doesn't get affected by dust, dirt, or other objects/cracks that would affect regular usage.

1.2. Fuse Protection

- 1.2.1. When the current exceed 0.5 A, the fuse would automatically disconnect, due to danger of overheating

1.3. Battery Safety

- 1.3.1. Use appropriate ventilation to avoid overcharging.
- 1.3.2. Ensure safe disposal of old batteries

5. References

1. Smith, J., Brown, R., & Wilson, K. (2019). *Effects of Cold Weather on Stray Cat Mortality Rates*. *Journal of Animal Welfare Studies*, 12(3), 45-58.
2. Zhang, L., Chen, Y., & Lin, X. (2021). *AI-Driven Species Recognition for Targeted Wildlife Assistance*. *International Journal of Computer Vision in Ecology*, 9(2), 102-118.
3. **Power Generation**
Tycon Systems 35W Solar Panel TPS-12-35W [Available at Digi-Key](#)
4. **Battery Type**
B.B. Battery BP1.2-12-T1 12V Rechargeable Battery [Available at Digi-Key](#)
5. **Heating Module**
Walbest 20W Reptile Heating Pad (Waterproof, Adjustable)[Available at Walmart](#)
6. **Microcontroller & Communication**
ESP32 WiFi+Bluetooth Development Board [Available at Adafruit](#)
7. **Temperature Sensor**
DHT22 Temperature & Humidity Sensor [Available at SparkFun](#)
8. **Solar Charge Controller**
EPEVER MPPT 20A Solar Charge Controller [Available at Renogy](#)
9. **Voltage Regulation**
LM2596 Buck Converter (12V to 5V) [Available at Digi-Key](#)
10. **Food Dispensing Motor**
NEMA 17 Stepper Motor (for controlled food dispensing) [Available at Pololu](#)