

ECE 445

SENIOR DESIGN LABORATORY

DESIGN DOCUMENT

---

# Smart Cognitive-Motor Rehabilitation Mat for Remote Exercise Monitoring

---

## Team #47

SCOTT LOPEZ (slope22@illinois.edu)

JASHAN VIRDI (jvird2@illinois.edu)

ADITHYA BALAJI (abalaji5@illinois.edu)

TA: Micheal Gamota

March 6, 2025

## Abstract

This design document provides an expansion on our initial project proposal, outlining the development of a Smart Cognitive-Motor Rehabilitation Mat for improving at-home physical therapy, particularly for individuals with Multiple Sclerosis (MS) and other mobility impairments that impact their ability to walk. The mat features a grid of pressure-sensitive Velostat sensors to detect user steps with high accuracy, providing real-time visual feedback via WS2812B LEDs. Addressing issues from previous prototypes such as unreliable sensors and a dependence on Wi-Fi, our improved design enhances reliability with larger sensor areas, better insulation, and Bluetooth-based data transmission using the ESP32-S3 microcontroller. The mat will also be engineered for durability, maintaining performance over at least 30 rolling cycles without sensor degradation. Ethical considerations, including data privacy (GDPR/HIPAA compliance), reliability, inclusivity, and safety, were kept in mind throughout our design approach. Through rigorous testing and validation, this project aims to deliver a cost-effective, accessible, and portable rehabilitation solution to physical therapy.

# Contents

- 1 Introduction** **1**
  - 1.1 Problem . . . . . 1
  - 1.2 Solution . . . . . 1
  - 1.3 High-Level Requirements . . . . . 2
  
- 2 Design** **3**
  - 2.1 Block Diagram . . . . . 3
  - 2.2 Overview of Subsystems . . . . . 3
    - 2.2.1 Mat Subsystem . . . . . 3
    - 2.2.2 Data Processing Subsystem . . . . . 5
    - 2.2.3 Power Subsystem . . . . . 7
  - 2.3 Requirements of Subsystems . . . . . 9
    - 2.3.1 Mat Subsystem . . . . . 9
    - 2.3.2 Data Processing Subsystem . . . . . 9
    - 2.3.3 Power Subsystem . . . . . 9
  - 2.4 Requirements and Verifications Tables . . . . . 9
  - 2.5 Tolerance Analysis . . . . . 10
    - 2.5.1 Power Subsystem . . . . . 10
    - 2.5.2 Bluetooth Transmission . . . . . 11
  
- 3 Cost and Schedule** **12**
  - 3.1 Cost Analysis . . . . . 12
  - 3.2 Estimated Part Costs . . . . . 13
  - 3.3 Schedule . . . . . 14
  
- 4 Ethics and Safety** **15**
  
- References** **16**
  
- Appendix A** **17**

# 1 Introduction

## 1.1 Problem

Multiple Sclerosis (MS) is a lasting disease that affects the central nervous system. This disease affects the myelin that protects the nerves and the loss of this protection causes scar tissue to form which hinders the transmission of signals along the nerves. MS can progress in two different ways: relapsing-remitting MS where there are repeated attacks and primary progressive MS where it progresses over time.[1] There are many symptoms that can help determine if a person has MS and how they should be treated. One form of treatment is rehabilitation physical activity such as walking. The smart mat aims to make this rehabilitation more accessible and safe for the patient at home.

Square stepping exercise is an accessible method for the rehabilitation of all individuals with MS. However, the current smart mat prototype has unreliable sensors and a dependency on Wi-Fi for the routines. The sensors sometimes show that a square that wasn't stepped on was, which gives false feedback and can discourage someone who is trying to improve. Also, the mat uses an html webpage to store the routines, and if Wi-Fi is not available in the location, these routines are unavailable.

## 1.2 Solution

The solution to the unreliable sensors is to increase the size of the Velostat squares and cover each side in copper to increase the area that will be detected. The wires connecting the Velostat will be insulated to prevent injury due to current flow and to help reduce fluctuations in voltage and current from outside sources. We will verify the new mat design can withstand repeated rolling and unrolling without degrading sensor reliability.

In order to solve the reliance on Wi-Fi, we will transfer over to Bluetooth and an IOS app to store the relevant data. Bluetooth does not require Wi-Fi to function and will allow the smart mat to work in locations with low Wi-Fi signals.

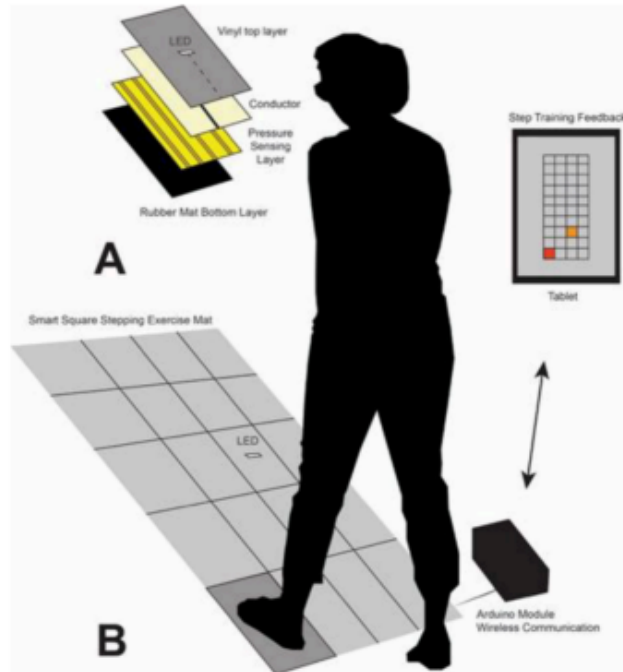

Figure 1: Visual Aid for smart mat (image credits: Professor Hernandez)

### 1.3 High-Level Requirements

We will consider our project a success if we complete the following requirements:

- **Data Transmission Latency:** The system must provide real-time feedback with a data transmission delay of no more than 500 ms between the smart mat and the mobile device.
- **Reliability:** Improve reliability of sensors to withstand multiple rolls .
- **Power Source:** Run the mat on a 5 V USB-C to allow ease of replacing power adapter.

## 2 Design

### 2.1 Block Diagram

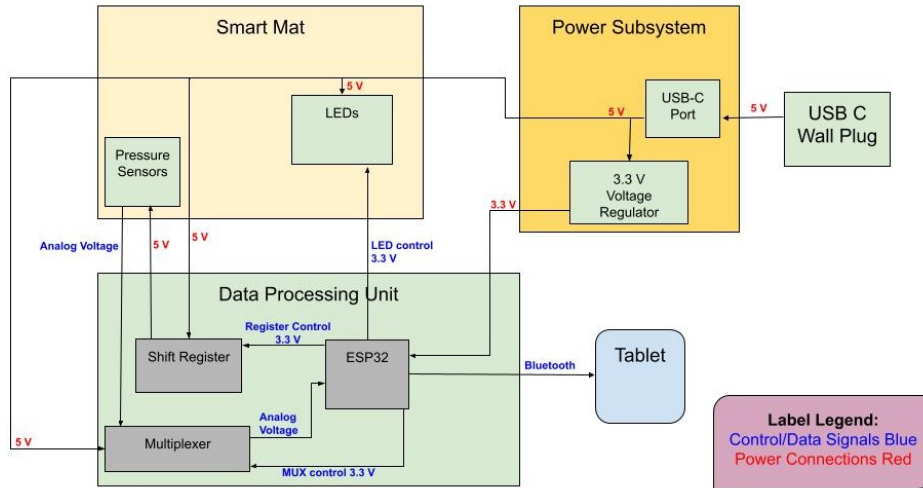

Figure 2: Block Diagram for smart mat

### 2.2 Overview of Subsystems

#### 2.2.1 Mat Subsystem

The mat consists of four main layers. The bottom layer is the anti-slip yoga mat which is intended to prevent the mat from slipping out from under the patient. The middle layer is the Wires and Velostat sensors. The LEDs are next and the top layer is a protective film.

The current design of the pressure sensor involves two copper stripes crossing with a Velostat layer in the middle as shown in Figure 3. Velostat is a pressure-sensitive conductive material that has decreasing resistance as pressure is applied. This allows for the detection of a patient's step by measuring the voltage difference across these stripes. This design was used due to Velostat's flexibility, allowing for use in a foldable mat. We decided to cover each side of the Velostat in copper foil as shown in Figure 4 to allow for a larger detection area to reduce the patient missing the sensor. To reduce incorrect readings, insulated wires will be used between each sensor to better isolate them and provide a better protective film that won't put pressure on the Velostat. The Velostat will still be arranged in a 4 x 10 grid with the wires connecting the sensors forming an (x,y) grid. These rows and columns will be read by the DPU to determine correct and incorrect steps. Each square on this grid is 30 cm x 25 cm to allow an adult foot to easily step on the required square.

Since we are planning to power this project with USB-C, we will use WS2812B LEDs because they run on 5 V. These LEDs are programmable through one data pin which will

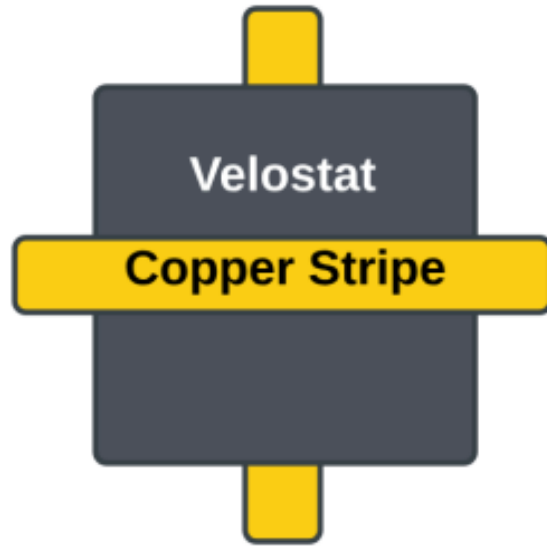

Figure 3: Current wire and Velostat configuration

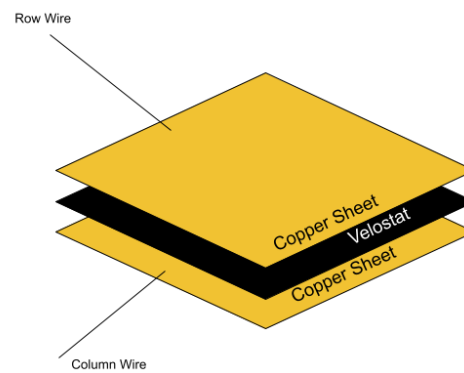

Figure 4: New Velostat Configuration

be connected to the ESP to allow for easy indication of which square needs to be stepped on. There will be 60 LEDs per meter to reduce the amperage of the LEDs. Each square will have 18 LEDs on either side and these will change between three different colors. Green indicates that the correct square was stepped on, while red indicates an incorrect square was stepped on. Blue will be used to show the user the next square in the routine that needs to be stepped on.

### **2.2.2 Data Processing Subsystem**

The data processing subsystem is made up of two main ICs and the microprocessor. The goal of this subsystem is to detect which of the 40 Velostat squares has been stepped on and compare this to the routine currently running on the microcontroller. After this, it changes the LEDs based on if the step was correct or incorrect.

The ESP for this project will be updated from an ESP32-S2 to a -S3. We switched over to the -S3 because it has a Bluetooth module that will be used to connect to an app that stores the routines. The -S3 is also a dual-core microcontroller. One core will be used to send and receive data through Bluetooth while the other core will determine which square was stepped on and what color needs to be outputted by the LEDs. The data that will be handled by the ESP Bluetooth module will be routines and steps. The ESP will be given a routine based on what is selected on the app. Based on this routine, it will scan the squares and check which step the person is on with the routine. It will determine if it is correct and display the proper color. The ESP will then output these steps to the IOS app.

The current scanning method will be retained in order to keep the GPIO pins to a minimum. This method uses an 8-bit shift register (SN54HC595) to supply a high signal to the columns. The ESP provides the initial one that will be shifted across four of the bits and the ESP also provides the clock signal which will run at around 100Hz rather than the previous 10Hz. This change in clock frequency will allow for more data samples. For each of the columns the register shifts through, the multiplexer (CD74HC4067) scans through 10 rows. If the voltage difference is greater than 1 V, then the ESP will read what column and row the multiplexer and shift register are currently on to determine which square was stepped on. As stated above, the ESP will then compare this with the routine.



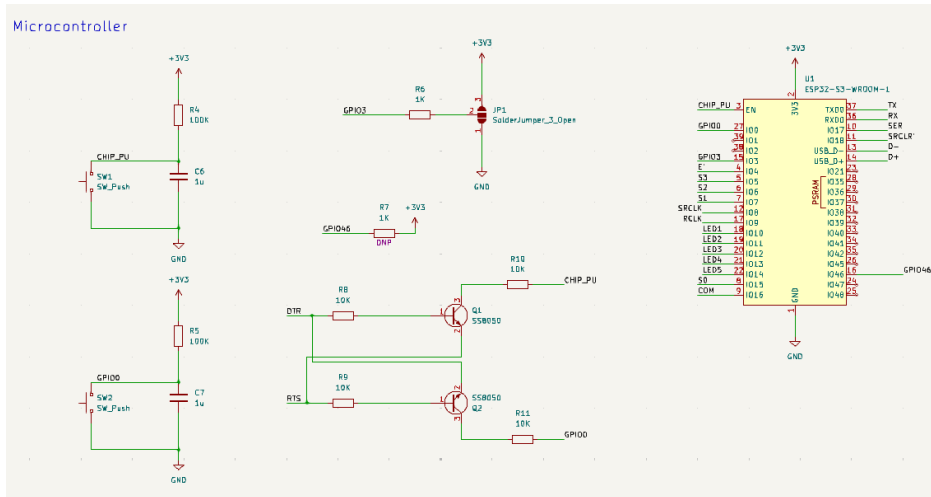

Figure 5: Microcontroller and Connections

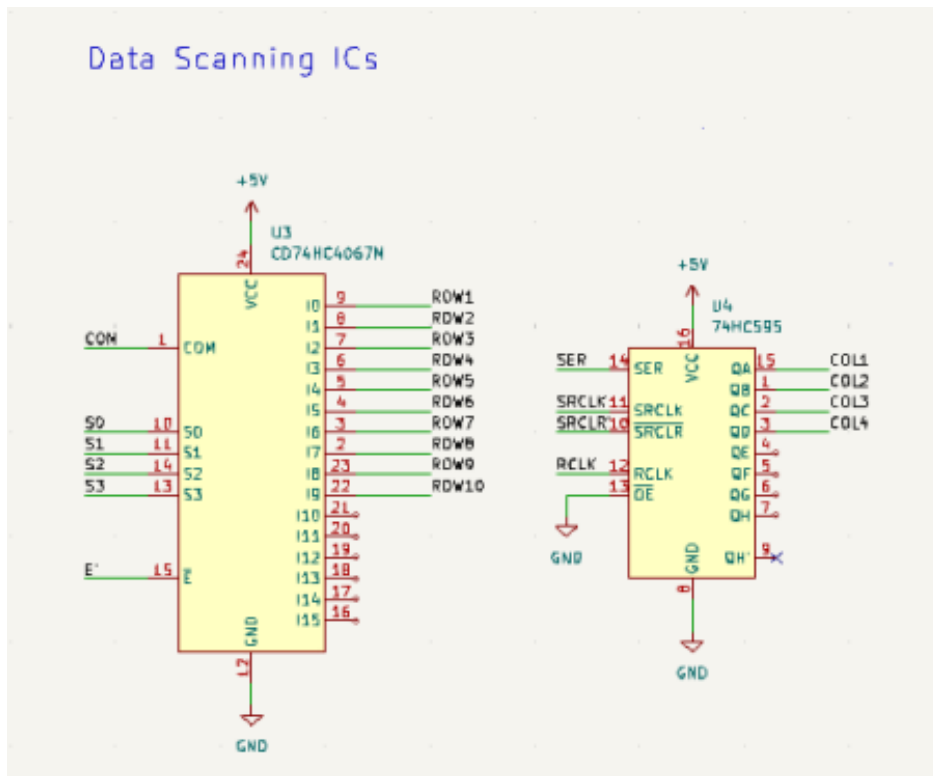

Figure 6: ICs and Connections

### 2.2.3 Power Subsystem

The power subsystem will provide power for the LEDs and the ESP32-S3. A USB wall plug will be used with a cable going to a USB-C port on the PCB. This 5 V power from the USB-C port will be distributed to the LEDs. There will also be a 5 V to 3.3 V voltage regulator (LM1117) on the PCB. This will provide the 3.3 V needed for the ESP32-S3. The shift register IC and multiplexer IC will be connected to 5 V.

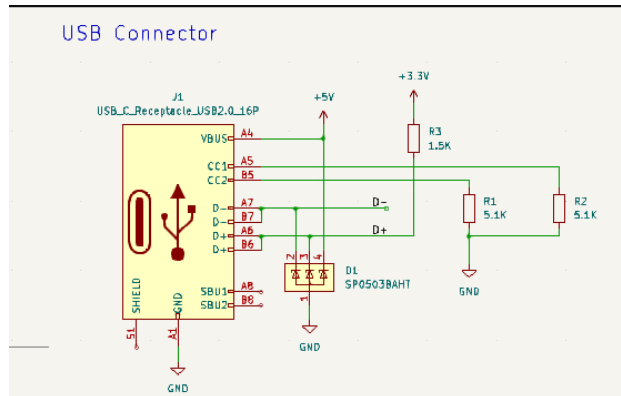

Figure 7: USB-C connector

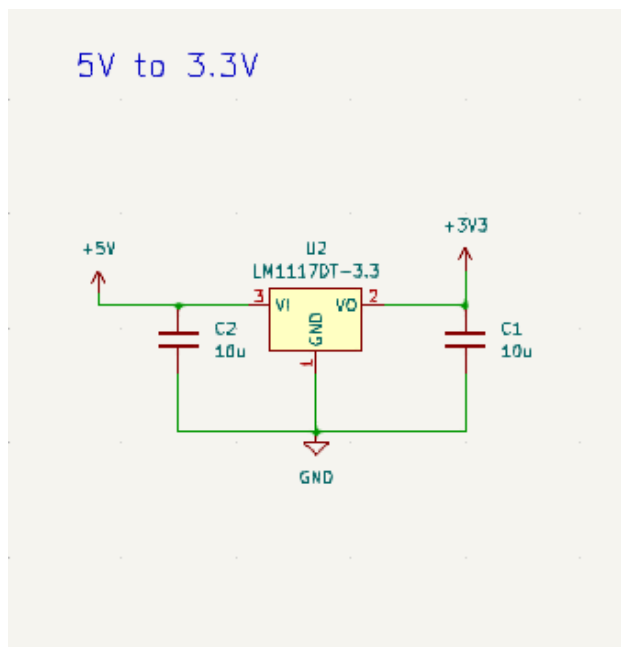

Figure 8: 5V to 3.3V Voltage Regulator

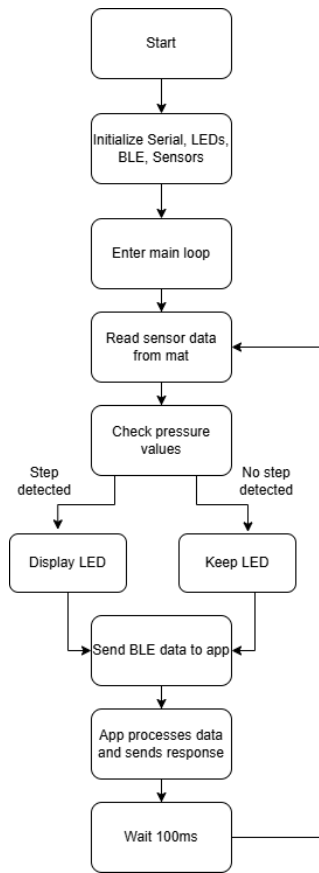

Figure 9: Flowchart of ESP code

## 2.3 Requirements of Subsystems

### 2.3.1 Mat Subsystem

- Can be rolled and unrolled at least 30 times without sensors inaccuracy
- The incorrect squares should not be activated if not stepped on
- Velostat should accurately detect if a person has stepped on them

### 2.3.2 Data Processing Subsystem

- Should correctly load shift register to keep correct scanning frequency
- Should send data accurately during routine within 500 ms
- Connected device should be able to transmit data across a room

### 2.3.3 Power Subsystem

- System should get  $5 \pm 0.3$  V and 10 A from USB-C
- System should be able to provide  $3.3$  V  $\pm 0.2$  V at 500 mA

## 2.4 Requirements and Verifications Tables

Table 1: Mat Subsystem

Requirements	Verifications
1) Can roll at least 30 times and sensors aren't affected 2) The incorrect squares should not be activated if not stepped on 3) Velostat should accurately detect if a person has stepped on them	1) Roll and unroll the mat 30 times. After this step on squares and measure the voltage. If within $\pm 0.05$ V from original test then good 2) Step and unstep on multiple squares in sequence. If an incorrect square was recorded isolate it and determine what the problem is related too. Fix problem then repeat first part 3) Step on each square individually and vary how it is stepped on. Record if it was sensed or not. Adjust voltage threshold if not detecting

Table 2: DPS Subsystem

Requirements	Verifications
1) Should correctly load shift register to keep correct scanning frequency 2) Should send data during routine within 500 ms and accurate 3) Connected device should be able to transmit data across a room	1) Measure shift-register outputs and if incorrect change ESP load timings 2) Check time to send and receive data through ESP timestamps and compare input to output for accuracy 3) Read data sent by ESP from varying locations in a room and compare accuracy

Table 3: Power Subsystem

Requirements	Verifications
1) System should get $5 \pm 0.3$ V from the USB-C port, and be able to draw enough current for the microcontroller and the LEDs (nominally 2.66 A) 2) System should be able to provide $3.3 \text{ V} \pm 0.2 \text{ V}$ to the ESP32-S3	1) Test with multimeter during use since LEDs take a lot of amperage. Voltage should be within bounds and current should be sufficient for the LEDs and microcontroller. 2) Use multimeter to test voltage

## 2.5 Tolerance Analysis

### 2.5.1 Power Subsystem

The power subsystem must be able to supply stable voltage to the ESP32-S3 and LEDs and be able to handle the current requirements from the ESP32-S3 and the LEDs.

Voltage Regulation:

- The USB-C port will be plugged into a wall charger with a USB-C cable, which should provide 5 V.
- The LM1117 voltage regulator is expected to step down  $5 \text{ V} \pm 0.3 \text{ V}$  to  $3.3 \text{ V} \pm 0.2 \text{ V}$ .
- The ESP32-S3 has an operating voltage range of 3.0 V – 3.6 V, so the  $3.3 \text{ V} \pm 0.2 \text{ V}$  output should remain within operational limits.
- A voltage drop beyond 3.0 V could lead to system instability, while exceeding 3.6 V risks damaging the micro-controller.

Current Requirements:

- The ESP32-S3 typically consumes 240 mA when WiFi/Bluetooth are active but may spike up to 500 mA during transmission.
- LEDs, depending on brightness, can consume significant current. Based on data

sheets each LED consumes around 60 mA.

- To determine the maximum current drawn at a time we need to determine the ESP current and LED current and use equation (1).

$$I_{total} = I_{ESP} + N_{LED}I_{LED} * 2 \quad (1)$$

Using this equation we know that the ESP maximum current is 500 mA and there are N=18 LEDs on each side of the square.  $18 * 2 * 60$  mA is 2.16 A. The total current draw during a squares activation is 2.66 A.

- The chosen USB-C connector is rated to handle 5 A, and there are several wall chargers with enough wattage to handle 2.66 A at 5 V. Power equals voltage times current, so anything rated  $5 * 2.66 = 13.3$  W or higher should be sufficient.
- If current draw exceeds 10 A which is well above the 2.66 A needed for a square to be illuminated, the USB-C port may trigger over current protection, shutting down power; however, this is unlikely to be a major issue as the total current consumed is well below the maximum. If the current draw exceeds 5 A, it may cause issues with the USB-C connector which is rated at 5 A.

Potential Failure Scenarios and Mitigation:

- Over current Draw: If current exceeds the 10 A limit, the USB-C power supply may trigger over current protection, shutting down the system. A current limiter or power management IC can be used to prevent this from occurring.
- Voltage Drops Under Load: Large current draws from LEDs may cause momentary voltage drops. This can be mitigated using bulk capacitors placed near high-current components.
- Heat Dissipation of LM1117 Regulator: If the LM1117 operates close to its current limit, it may generate excess heat. A heat sink or a switching regulator alternative (e.g., a buck converter) could improve efficiency and reduce heat buildup.

## 2.5.2 Bluetooth Transmission

The ESP32-S3 Bluetooth module is required to maintain stable data transmission across a room using **Bluetooth Low Energy (BLE)**, which is a low-power wireless communication standard used for short-range data exchange. Signal Range and Attenuation: The ESP32-S3 has a BLE 5.0 module with a typical indoor range of 10-30 meters, depending on interference.

- Signal strength (RSSI) can be estimated using:

$$P_r = P_t + G_t + G_r - 20 \log_{10}(d) - L \quad (2)$$

Where:

- $P_r$  = received power (dBm)

- $P_t$  = Transmit power (dBm)
- $G_t, G_r$  = Antenna gains
- $d$  = distance (m)
- $L$  = path loss (typically, 30-40 dB at 10 m for indoor environment)
- Since BLE connections are reliable above -90 dBm, the ESP32-S3 should maintain a stable connection up to 30 meters in ideal conditions; however, walls, furniture, and interference from other devices (Wi-Fi, microwaves) could reduce this range.

#### Data Transmission Latency

- The system requires data transmission within 500 ms.
- BLE has a latency of 30 ms per packet, so even with multiple packets per step, transmission should remain well below 500 ms. This should not be of major concern at all.

#### Design considerations for optimal BLE performance:

- **Antenna Placement:** The ESP32-S3's onboard antenna should be positioned away from metal enclosures or high-power circuits to maximize signal strength. External antennas can be used for improved performance if necessary.
- **Power Optimization:** Reducing transmission power when high signal strength is unnecessary can improve battery life while still maintaining stable communication.
- **Error Correction and Packet Retransmission:** Implementing BLE error correction features can help mitigate data loss in environments with high interference.
- **BLE Mesh Networking:** If extended coverage is needed, a BLE mesh network can be implemented to relay data across multiple nodes.

## 3 Cost and Schedule

### 3.1 Cost Analysis

Assuming an hourly rate of \$44 per hour, at around 2.5 hours a day, and 50 days total, the cost of labor per person would be  $\$44 * 2.5 * 50 = \$5500$ . For 3 team members, the total cost would be three times  $\$5,500 = \$16,500$ .

### 3.2 Estimated Part Costs

Table 4: Estimated Part Costs

Part Number/Description	Manufacturer	Quantity	Cost
ESP32-S3-WROOM-1	Espressif Systems	1	\$5.06
USB4085-GF-A (USB-C Connector)	GCT	1	\$0.88
1935174 (3 position terminal block)	Phoenix Contact	5	\$0.55
0022232101 (10 position header)	Molex	1	\$0.54
0022232041 (4 position header)	Molex	1	\$0.28
PPTC051LFBN-RC (5 position header)	Sullins Connector Solutions	1	\$0.42
LM1117DT-3.3/NOPB (Voltage Regulator)	Texas Instruments	1	\$1.69
SN74HC595DR (Shift Register)	Texas Instruments	1	\$0.26
CD74HC4067M96 (16:1 MUX)	Texas Instruments	1	\$0.58
B3S-1000 (Switch)	Omron Electronics Inc-EMC Div	2	\$0.57
SP0503BAHTG (Diodes)	Littelfuse Inc.	1	\$0.70
GRM21BR61H106ME43L (10 uF capacitor)	Murata Electronics	3	\$0.26
CL21B105KBFNNG (1 uF capacitor)	Samsung Electro-Mechanics	3	\$0.10
CL21F104ZAANNNC (0.1 uF capacitor)	Samsung Electro-Mechanics	1	\$0.10
RMCF0805JT1K00 (1kOhm resistor)	Stackpole Electronics Inc	2	\$0.10
RMCF0805FT1K50 (1.5kOhm resistor)	Stackpole Electronics Inc	1	\$0.10
RMCF0805JT5K10 (5.1kOhm resistor)	Stackpole Electronics Inc	2	\$0.10
RMCF0805JG10K0 (10kOhm resistor)	Stackpole Electronics Inc	4	\$0.10
RMCF0805JT100K (100kOhm resistor)	Stackpole Electronics Inc	2	\$0.10
(1528-2211-ND) Velostat	Adafruit	1	\$4.95
(WS2812B) Addressable LEDs	LOAMLIN	5	\$19.99



Adding the estimated labor cost and the cost of all parts results in a total estimated cost of  $\$16,500 + \$117.39 = \$16,617.39$ .

### 3.3 Schedule

The following schedule will allow us to efficiently split up manpower and resources, as well as keep track on the different parts of the project to make sure we will meet the eventual goal of having a functional product ready for the final demo.

Table 5: Schedule by week and Members

<b>Week</b>	<b>Tasks</b>	<b>Members</b>
3/3	Work on Breadboard prototype	All members
3/10	ESP Bluetooth	Adithya
3/17	Spring break	N/A
3/24	Solder and test PCB	Jashan, Scott
3/31	Build mat	All Members
4/7	Build mat, make new PCB if needed	All Members
4/14	Test/debug project	All Members
4/21	Mock demo, begin final report and final presentation	All Members
4/28	Prepare for final demo, practice final presentation	All members
5/5	Finish final report, presentation	All Members

## 4 Ethics and Safety

### Data Privacy and Security (IEEE Code of Ethics, Principle #1 & #5) [2]

- The smart mat collects user activity data, which could include sensitive health-related information. Unauthorized access or misuse of this data has the potential to lead to privacy violations.
  - To mitigate risks, we will be aiming to encrypt data transmission for the Bluetooth implementation and have the mat ready to comply with relevant privacy laws such as GDPR and/or HIPAA if used in a medical setting.

### Reliability and Accuracy (IEEE Code of Ethics, Principle #3 & #6) [2]

- When making modifications to the existing prototype, we would need to ensure the mat continues to accurately detect user steps and respond with minimal latency to avoid incorrect feedback, which could lead to ineffective training or injury.
- Proper testing and verification against ground truth data would need to be conducted before the mat is ready to be used in a consumer setting.

### Accessibility and Inclusivity (ACM Code of Ethics, Principle 1.4) [3]

- The mat would ideally be designed for a diverse range of users, including those with disabilities, to ensure inclusivity and as many recovering patients as possible to use the smartmat.

### Responsible Development and Testing (IEEE Code of Ethics, Principle #9) [2]

- We would seek to ensure safety during actual mat testing if any, making sure there is no possibility of loose electrical components or improper sensor readings that could mislead users.

## References

- [1] John Hopkins Medicine. ““Multiple Sclerosis (MS)”.” (2025), [Online]. Available: <https://www.hopkinsmedicine.org/health/conditions-and-diseases/multiple-sclerosis-ms> (visited on 03/01/2025).
- [2] IEEE. “IEEE Code of Ethics.” (2016), [Online]. Available: <https://www.ieee.org/about/corporate/governance/p7-8.html> (visited on 03/01/2025).
- [3] Association for Computing Machinery. “ACM Code of Ethics and Professional Conduct.” (2018), [Online]. Available: <https://www.acm.org/code-of-ethics> (visited on 03/01/2025).

## Appendix A

[1] M. E. Hernandez et al., "INTELLIGENT SQUARE STEPPING EXERCISE SYSTEM FOR COGNITIVE-MOTOR REHABILITATION IN OLDER ADULTS WITH MULTIPLE SCLEROSIS," in Proc. 2025 Design of Medical Devices Conf., Apr. 2025.

[2] "ESP32-S3-WROOM-1 ESP32-S3-WROOM-1U Datasheet 2.4 GHz Wi-Fi (802.11 b/g/n) and Bluetooth® 5 (LE) module Built around ESP32-S3 series of SoCs, Xtensa® dual-core 32-bit LX7 microprocessor Flash up to 16 MB, PSRAM up to 8 MB 36 GPIOs, rich set of peripherals On-board PCB antenna." Available: [https://www.espressif.com/sites/default/files/documentation/esp32-s3-wroom-1\\_wroom-1u\\_datasheet.en.pdf](https://www.espressif.com/sites/default/files/documentation/esp32-s3-wroom-1_wroom-1u_datasheet.en.pdf)