

ECE 445: Design Document

Climate Control Grow Box

Andrea Gardner (agardn7)

Gabrielle Wilki (gwilk2)

Rhea Tiwari (rtiwari3)

1 Introduction.....	3
1.1 Problem.....	3
1.2 Solution.....	3
1.3 Visual Aids.....	4
1.4 High Level Requirements List.....	5
1.5 Design.....	6
1.5.1 Block Diagram.....	6
1.5.2 Subsystem Overview.....	6
Humidity Control Subsystem.....	6
Light Control Subsystem.....	7
Water Subsystem.....	8
Control Subsystem.....	9
2 Tolerance Analysis.....	12
2.1 Power system.....	12
2.2 Humidity.....	12
3 Cost and Schedule.....	13
3.1 Cost Analysis.....	13
3.2 Schedule.....	14
4 Discussion of Ethics and Safety.....	14
5 Citations.....	15

1 Introduction

1.1 Problem

Many houseplants struggle to survive due to the indoor environmental conditions they are brought into, which often do not match their specific climate needs. Often times these plants which may not be native to the region even if they could benefit from the natural climate control of the new location by being planted outside often have to deal with the indoor environment where factors like too high or low humidity levels, excessive or lack of lighting, and water availability all contribute to a plants deteriorating ability to thrive or even the plants death.

To combat this and allow for non native plants to be grown all over the world climate control solutions have been created however, existing climate control solutions tend to be designed for large areas, such as entire rooms or whole buildings, meaning in a residential setting that the houseplant owners must live in the same environment as their houseplants for them to thrive which can become difficult for owners with houseplants that have different climate needs or would prefer not to live in the same extreme environment that their plants do best in.

The issue with existing solutions hence is that these solutions lack the ability to create small, isolated climate zones suited for specific plants with unique needs particularly, there is a lack of a targeted climate control system that allows individuals to maintain ideal conditions for a select few plants in a residential building where space is at a premium and a smaller easy to use model may be more appropriate for the houseplant owner.

1.2 Solution

Our solution is to design a small climate controlled grow box that is designed with the space constraints of a typical residential home. This box will have the ability to regulate and modify the current humidity percentage, airflow through the enclosure, light intensity levels, along with watering amount. By controlling these variables we can create a better suited environment for the plant than that provided by the average interior climate for the plants being grown. We will do this by having Humidity Control, Lighting Control, Water Control, Power control, and a control subsystem that will work together to create a small self contained climate.

1.3 Visual Aids

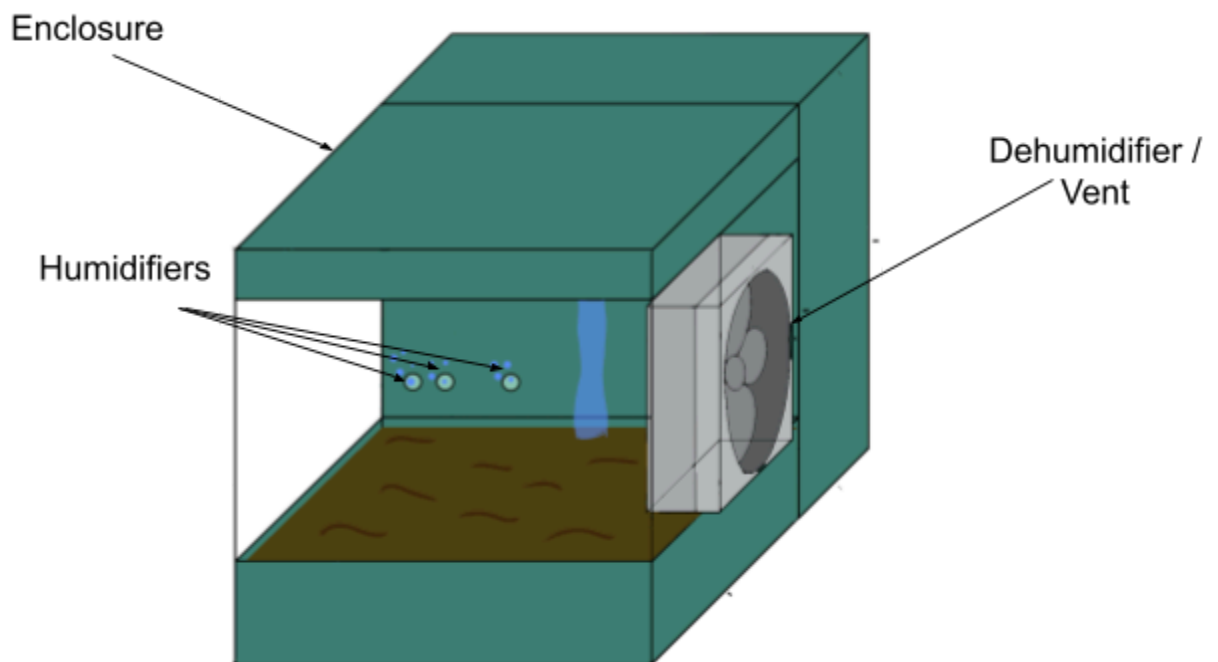

Figure 1: Visual of major components of Grow Box

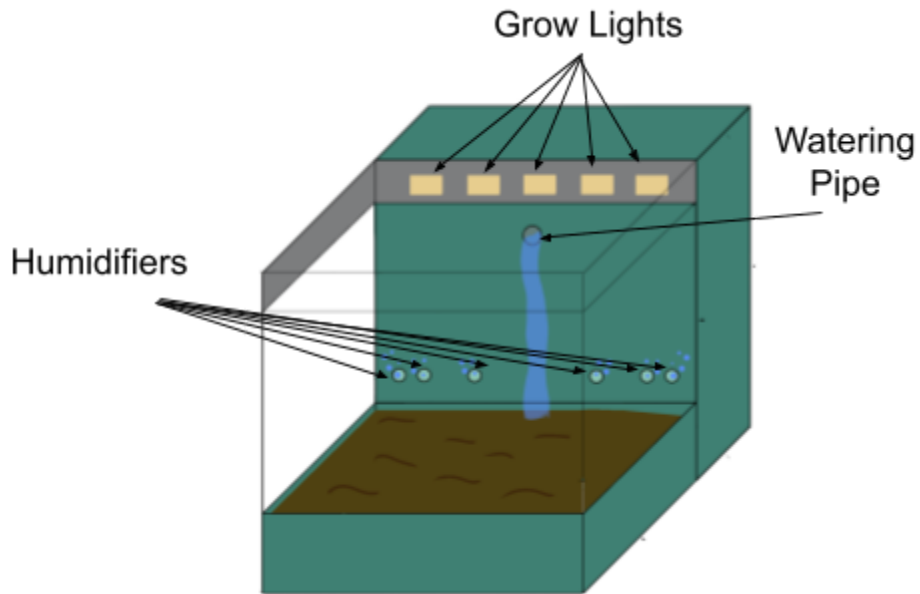

Figure 2: Visual of major components of Grow Box (Cross section)

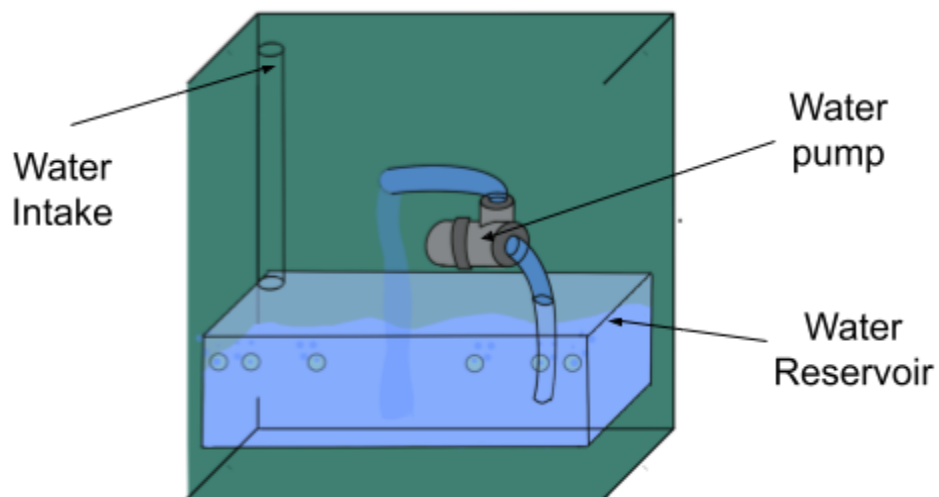

Figure 3: Visual of hidden components of Grow Box

1.4 High Level Requirements List

Accuracy: Our first requirement is to have high level of accuracy within the control system to maintain the desired environment type with a low tolerance for fluctuations.

Humidity levels should have a tolerance of $\pm 5\%$ humidity when set in the acceptable range of $\pm 10\%$ of the external humidity levels. The water dispersions should remain similar levels of accuracy when distributing water in increments of 1/4 cup allowing an error bounds of $\pm 10\text{g}$ per dispersal of water. Doing this ensures that we will provide the needed stability within the environment to keep the plants inside in the correct conditions while also optimally using our resources by avoiding over watering or over-humidifying the enclosure.

Ease of use: This product must be accessible to the average consumer in ease of use. This product should be moveable by a single person and thus must weigh less than twenty five pounds when not filled with soil and water. feature a single, unified chassis, with all components contained within it, except for a singular power cable if needed for the design. Ensuring this ease of use makes it practical for not only a larger group of consumers but also for us to develop the product.

Responsivity: When the user selects a new climate option the system will respond and begin the change process within five seconds from button select to initiation.

Additionally the system needs to respond to external stimuli in a timely manner. External stimuli should be detected at minimum every three minutes and similarly to user input should begin the change process within five seconds of detecting the external stimuli.

Having this kind of response time will allow for proper setting of the internal climate and keeping it there without needing to adjust on too regular intervals and be oscillating between on and off states.

1.5 Design

1.5.1 Block Diagram

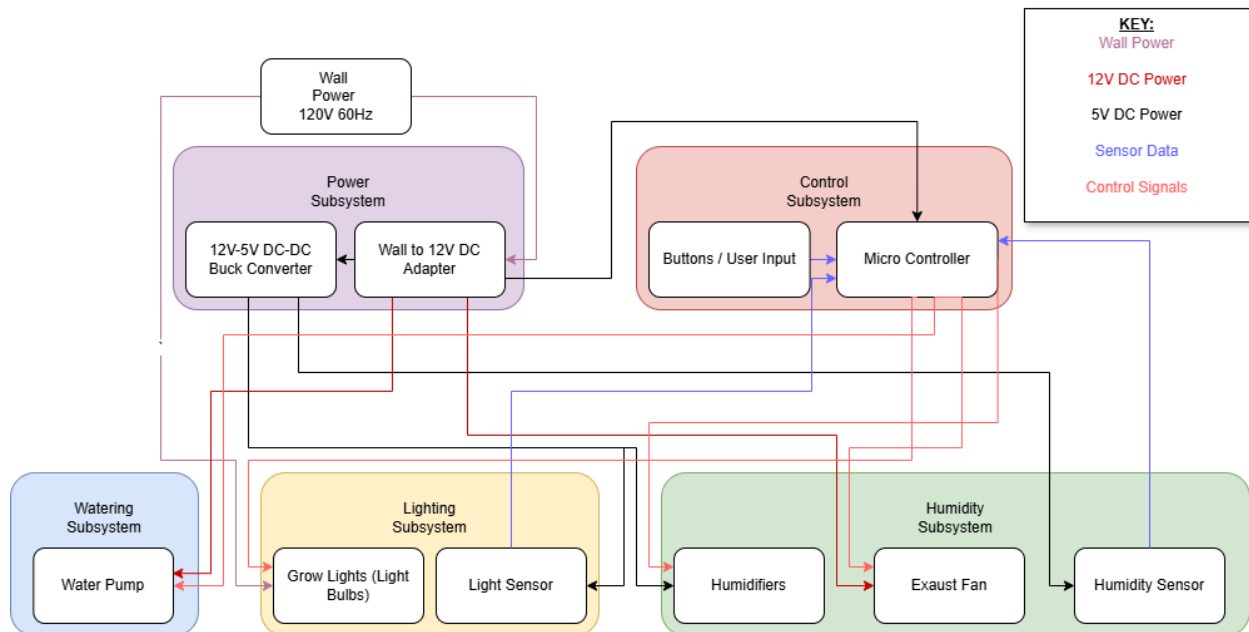

1.5.2 Subsystem Overview

Humidity Control Subsystem

The humidity control subsystem is responsible for the monitoring of and the regulation of humidity within the enclosure of the grow box. It has four main components: a humidity sensor [4], a vent fan, a series of small scale humidifiers [3], and a water reservoir that is shared with the water subsystem. The humidity sensor will be responsible for detecting the current humidity within the system and will send the information to the control subsystem for it to process and compare with a user set humidity level. If the detected humidity is too low the control system will turn on the

power to the humidifiers which will pull water from the water reservoir and turn water to mist increasing the humidity levels in the enclosure, by keeping them on until an acceptable tolerance in humidity level is reached in comparison to the user input. If the detected humidity is high the control system will turn on the power to the ventilation fan and keep them on until an acceptable tolerance in humidity level is reached in comparison to the user input. This system is reliant on the power subsystem to power its components along with the control subsystem to do the comparisons and handle the reading of the humidity sensor.

Requirements and Verifications table:

Requirement	Verification
The humidity must be sensed with an accuracy of $\pm 5\%$	<p>We will verify these readings with a Reliable Hygrometer</p> <p>We will place our humidity sensor next to a calibrated hygrometer and compare the readings between the two sensors over that span of several minutes while changing the humidity in the environment and comparing the expected results.</p>
We must be able to raise the humidity within the enclosure by 10% in comparison to the external humidity level	<p>We can verify this by taking an external read of the current humidity, if the reading is less than 70% we can continue the verification, else we must find an environment with less than 70% humidity. In an environment with less than 70% humidity we will then activate the humidifiers within the enclosure and measure how long and if it is possible to increase the humidity by 10%.</p>
We must be able to lower the humidity within the enclosure by 10% in comparison to the external humidity level	<p>We can verify this by taking an external read of the current humidity, if the reading is greater than 30% we can continue the verification, else we must find an environment with greater than 30%</p>

	<p>humidity. In an environment with greater than 30% humidity we will then activate the ventilation fan within the enclosure and measure how long and if it is possible to decrease the humidity by 10%.</p>
--	--------------------------------------------------------------------------------------------------------------------------------------------------------------------------------------------------------------

Light Control Subsystem

The Light Control subsystem will be responsible for monitoring and controlling the light intensity level within the enclosure. It will contain two main components; one light intensity detector along with grow light bulbs. The light intensity sensor will be responsible for detecting the current level of light in the enclosure and transmitting the results to the control unit which will determine if the current light levels are at or above the user requested light levels. If the control unit determines that the light in the enclosure is less than what was requested then the control unit will turn on the grow lights, if the light detected is at or greater than is needed the lights should turn or remain off. This system is reliant on the power subsystem to power its components along with the control subsystem to do the comparisons and handle the reading of the light intensity sensor.

Requirements and Verifications table:

Requirement	Verification
<p>The luminosity level must be sensed with an accuracy of +-5lx</p>	<p>We will verify these readings with a Reliable luminosity sensor</p> <p>We will place our luminosity sensor next to a calibrated luminosity sensor and compare the readings between the two sensors over that span of several minutes while changing the light levels in the environment and comparing the expected</p>

	results.
The lights must turn on with an external signal and increase the light in an environment with less than 1000 lx	We can verify this by taking an internal read of the current light level, if the reading is less than 1000 lx we can continue the verification, else we must find an environment with less than 1000 lx. In an environment with less than 1000 lx we will then activate the lights within the enclosure and measure the new light level.

Water Subsystem

The Water Subsystem will be responsible for the water distribution for the plants inside the enclosure. This system has only two major components: a water pump with tubing connecting its inputs and output to a water reservoir that is shared with the humidity subsystem and the plant enclosure respectively. The water pump will be activated by the control subsystem and will be programmed to release 1/4 cup of water increments at a determined time interval as set by the user. The control system will also be responsible for determining the time needed to run the pump to reach this volume of water distributed.

Requirements and Verifications table:

Requirement	Verification
Must be able to accurately dispense water using timed dispensation in 1/4 cup intervals up to dispensing the entire reservoir	We will verify this by measuring the water dispensed with a weight scale to verify that it is within the tolerance of 10g of water per dispensation of water into the enclosure.

Must be able to stop dispersal of water within three seconds after the signal to dispense water has ended	We will test this by starting and stopping the water at varying intervals and ensuring that the water flow stops within the three second interval by timing the time it takes to stop flowing
-----------------------------------------------------------------------------------------------------------	-----------------------------------------------------------------------------------------------------------------------------------------------------------------------------------------------

Control Subsystem

This system will use buttons to select the value for the lighting, watering, and humidity.

The controller will take these values and use them to determine how to act with the system.

The watering system will be controlled by a timer, after a given time that is determined by the user selection the pump will water the plants.

Both the lighting system and the humidity sensor will be used to control. The lighting system

The humidity system will be a basic feedback control loop. The sensor value will be compared to that of the selected value and it will be used to determine how the system will act. If the system is on the lower end of the desired humidity the humidifiers will activate, when the system is within the desired range the sprayers will deactivate. The same is true for the fan, when the system is above the desired humidity range the fan will turn on and run until the system has reached the value that it wants.

For the most part the controller will be acting as the pulse input to a MOSFET. When the component needs to be turned on then there will be a positive pulse applied.

Requirements and Verifications table:

Requirement	Verification
Must be able to create the control variables for humidity and light	Test to see if the user inputs are being stored accurately and see if the signals are getting through to the sensors
Must be able to operate timer control for the water subsystem	Test to see if the water being dispensed is the correct amount
The controls must correctly activate the MOSFETs	<p>To check if the MOSFETs are being correctly controlled first connect a multimeter to the drain and source legs of the MOSFET(the two which are not connected to the signal).</p> <p>Add a voltmeter to the gate to where the chip is providing the signal. The signal produced by the ATmega should be seen on this device.</p> <p>When the signal is high we should see on the multimeter that there is a resistance of around zero in the MOSFET when the gate sees a high pulse. A large resistance should be seen when the gate is receiving a signal of zero.</p> <p>By doing this we can test to see if the MOSFETs are working as anticipated.</p>

Power Subsystem

The goal of The Climate Control Grow Box is to be left unattended for extended periods of time. Since we want the system to be self-contained the main source of power will need to be drawn from the wall. This will eliminate the need to charge a battery as well as allow for the system to operate on its own.

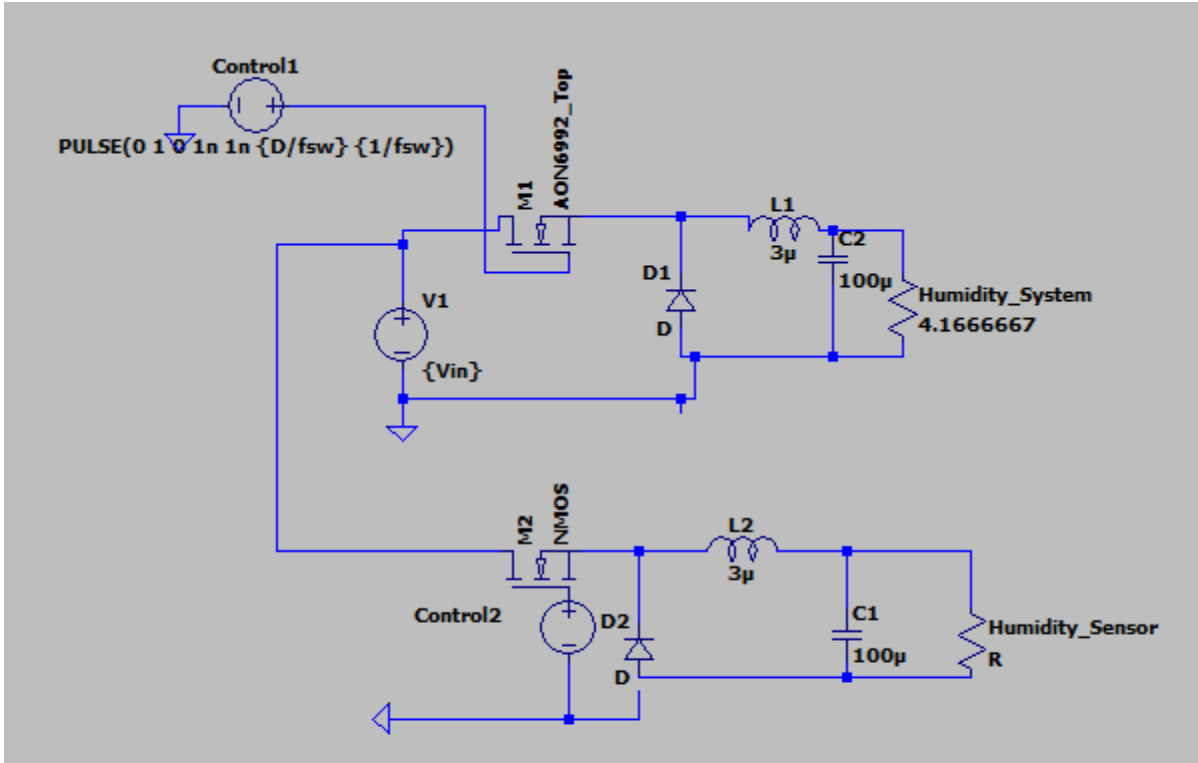

In the figure above, the LTSpice simulation for the buck converters. This simulation is used to determine the current and voltage values that will be going across the various components. This will ensure that when the components are selected that they meet the minimum tolerance requirements for what they are doing.

When the control to the buck converter is initiated, it will be provided a base signal with a set frequency and duty ratio. Due to the constraints on time for this project there will be no consideration made towards the deterioration of the components comprising the converter.

Requirements and Verifications table:

Requirement	Verification
-------------	--------------

Buck converter is required to provide a 5 volt DC output from a 12 volt DC source with a voltage ripple of 5%.

To Test this a 5 ohm or greater resistor should be placed into the position where the system will be. If the resistor value is less than 5 ohms you run the risk of overloading the current which the system can handle.

On this resistor hook up the oscilloscope, when powered on the viewer should see a signal that sits within 5.25V and 4.75V.

2 Tolerance Analysis

2.1 Power system

The current main concern from the power system is then non-ideality of systems. All of the components that we are purchasing should, even in the worst case, still meet the minimum specifications. With that in mind, when creating the system the series resistance and capacitance of the components was not brought into consideration. This means there will be a greater pull on the system’s power needs. That in mind is the system has been made in such a way that it can handle these slight changes in drawn power. The 12V supply can provide up to around 70W of power, all of the systems drawing from it will require less than 10W in total. The next concern for the power system will be the diode drop. Given how much we are reducing the initial voltage this can be overcome with changes in the system’s duty ratio.

2.2 Humidity

We plan to have a volume of 2 cubic feet or roughly 0.0566337 cubic meters for the plant enclosure. Given the average room temperature of 72° Fahrenheit (20° Celsius). This temperature has a saturation point of 2.34 kPa.

To calculate Relative Humidity (RH) from Absolute Humidity (AH) and temperature, use the formulas:

$$RH = (AH / \text{Saturation Vapor Pressure at given temperature}) \times 100$$

$$\text{Absolute Humidity [AH] (g/m}^3\text{)} = (\text{Mass of Water Vapor (g)} / \text{Volume of Air (m}^3\text{)})$$

where "Saturation Vapor Pressure" is the maximum amount of water vapor the air can hold at a specific temperature, and is typically found using a table or a formula based on temperature.

Our humidifiers can atomize water at a rate of 40-50 ml/h and with six of them active at once that provides approximately 240-300 g/hr of water being added to the air or 4-5 g/minute

$$40\text{-}50 \text{ ml/h} * 6 = 240\text{-}300\text{ml/hr} = 240\text{-}300 \text{ g/hr} = 4\text{-}5 \text{ g/m}$$

On the lower bound of 4g/m

$$\Delta AH = 4 \text{ (g/min)} / 0.0566337 \text{ (m}^3\text{)} = 70.629 \text{ ((g/m}^3\text{)/min)}$$

We can find the change relative humidity per minute by

$$\begin{aligned} \Delta RH &= (\Delta AH / \text{Saturation Vapor Pressure}) * 100 \\ &= (70.629 / 781.95730806) * 100 \\ &= 9.032 \text{ humidity \% / m} \end{aligned}$$

With a volume of 0.0566 cubic meters to increase the humidity level within the enclosure 10% it would take approximately 1.107 minutes.

3 Cost and Schedule

3.1 Cost Analysis

The total that we will spend on the system will be \$95.15 for the hardware. There were many components that we were able to find through the supply in the Self Service within ECEB. These components were not considered in our costs, these components cost \$6.82. The total materials cost would be \$101.97.

Description	Vendor	Quantity	Price	Link
Exhaust Fan	Amazon	1	\$30.99	link
LED 50W Plant Grow Lights	Amazon	1	\$6.50	link
Input voltage 120AC 60 Hz to 12V Dc 6A	Amazon	1	\$13.59	link
Humidifier System	Amazon	6	\$13.99	link
3μH Power Inductors	Mouser	2	\$1.84	link
GRAVITY: I2C IP68 WATERPROOF AMB	Mouser	1	\$8.13	Link
IC MCU 8BIT 32KB FLASH 32TQFP	Digi-Key	2	\$2.47	
Temperature and Humidity Sensor		1	\$9.80	
100 uF Tantalum Capacitor rated for 6V	Self Service	2	\$1.52	N/A
Schottky Diode	Self Service	2	\$0.40	N/A
NMOS	Self Service	5	\$4.90	N/A

We also need to consider the cost that comes from the labor that we will be putting into this project. According to the UIUC Financial Wage site, we would qualify as paraprofessional employees and would make between \$15.00-\$22.50 an hour[1]. Since this group comprises entirely seniors, we would qualify for the greater end of that scale. With this the total cost of labor would be $100(\text{hr}) * 22.50(\$/\text{hr}) = \2250.00 .

In the end the total cost of this project would be \$2351.97, this includes the components which we will not need to purchase.

3.2 Schedule

<u>Week</u>	<u>Task</u>	<u>Person</u>
March 3rd - March 9th	Completed PCB design	Rhea
	Begin debugging PCB	Rhea and Gabby
	Begin working on breadboard	Everyone
March 10th - March 16th	Test circuit ready for breadboard review	Everyone
	Send order for PCB	Rhea and Gabby
	Machine shop orders	Andrea
March 17th - March 23rd	Spring Break	Everyone
March 24th - March 30th	Begin working on power and control system - PCB	Andrea
	Begin working on water, humidity, and light subsystems - wiring and connecting them to the sensors/humidifier	Rhea and Gabby
	Revise PCB as needed	Rhea
March 31st - April 6th	Individual progress reports	Everyone
	Start building the box	Andrea and Gabby
	Debug the power and control subsystem	Andrea
	Debug the water, humidity, and light subsystems	Rhea and Gabby

	Revise PCB as needed	Rhea
April 7th - April 13th	Finish building the box	Andrea and Rhea
	Finish the power and control subsystem and connect to box	Andrea
	Finish the water, humidity, and light subsystems and connect to box	Rhea and Gabby
April 14th - April 20th	Team contract assessment	Everyone
	Makes sure everything works together	Everyone
April 21st - April 27th	Mock demo	Everyone
	Fix bugs in demo	Everyone
	Finish presentation	Everyone
April 28th - May 4th	Final demo	Everyone
	Mock presentation	Everyone
	Fix presentation	Everyone
	Finish final paper	Everyone
May 5th - May 11th	Final Presentation	Everyone
	Final Paper	Everyone
	Lab notebook	Everyone

4 Discussion of Ethics and Safety

There are a few areas of concern we have for the development of this project. These include connecting the operating system directly to the power grid and operating and designing electronics near water. If we are not careful with how we handle these issues they can cause harm to the person who is using the product, which would go against the IEEE code of ethics[2]. To

maintain the health and safety of those who will use our system we will take measures to ensure that no harm will come to the persons who will be operating the system.

The primary issue when working with power connected to the grid is the chance for a severe electric shock. We will manage this by ensuring that when we connect up the system it is connected to an extension cord which has an independent power switch. If we are able we will work with a system that will have a fuse as a layer of protection to prevent current from connecting to a human. The second thing we will do is ensure that the connectors to the lights which require the larger voltage and power are secured and closed from the system. There will also be steps taken to ensure that the system remains separated from the other systems.

We will also make special care to design the water requiring subsystems to ensure that no water will interact with electronic components while constructing the grow box or while the grow box is in operation. Additionally we will verify that we have a dry surface and components before working on the circuitry or with any electronic components to prevent any injury or destruction of components due to water exposure to components not designed for water usage.

5 Citations

[1]“Wages – Office of Student Financial Aid,” *Illinois.edu*, 2024.

<https://osfa.illinois.edu/types-of-aid/employment/regulations/wages/> (accessed Mar. 06, 2025)

[2]IEEE, “IEEE Code of Ethics,” *ieee.org*, Jun. 2020.

<https://www.ieee.org/about/corporate/governance/p7-8.html> (accessed Mar. 06, 2025)

[3]“Amazon.com: SazkJere 6Pcs USB Humidification Atomization Disc Type-C Interface DC 5V Atomization Drive Circuit Board : Home & Kitchen,” Amazon.com, 2025.

https://www.amazon.com/dp/B0CZN74JCV/ref=sbl_dpx_hvac-humidifiers_B0D4TZ8K8R_C1v (accessed Feb. 13, 2025).

[4] “Amazon.com: ATIMOSOS 1PC Wired DHT22/AM2302 Digital Temperature and Humidity Sensor AM2302 : Appliances,” Amazon.com, 2025.

https://www.amazon.com/ATIMOSOS-AM2302-Digital-Temperature-Humidity/dp/B073TW7V1T?source=ps-sl-shoppingads-lpcontext&ref_=fplfs&pvc=1&smid=AXI6THZLFAAC34&gQT=1 (accessed Feb. 13, 2025).

[5]M. Amaral, “What is humidity and how do you measure it?,” Cotes.com, Jan. 14, 2022. <https://www.cotes.com/blog/what-is-humidity-and-how-do-you-measure-it>

[6]“Product documentation portal,” Vaisala.com, 2025.

<https://docs.vaisala.com/r/M211280EN-D/en-US/GUID-BF3EEF1B-ECEF-4B2C-AB1C-5F7DD642D24C> (accessed Feb. 13, 2025).

[7]“Arm®Cortex®-M0+ 32-bit MCU,” st.com.

<https://www.st.com/resource/en/datasheet/dm01085881.pdf>

[8] “AC to DC 12V 10A 120W Power Supply Adapter Converter Regulator, 5.5mm X 2.1mm DC Plug, 12Volt 10Amp Wall Power Plug for DC12V 5050 5630 Flexible LED Strip Lights,” Amazon.

https://www.amazon.com/BINZET-Adapter-Converter-Regulator-Flexible/dp/B00Z9X4GLW/ref=sr_1_2_sspa?crd=174JTYRVVTD5M&dib=eyJ2IjoiMSJ9.TcCqiIcE8sm_lJA-20lCdKTN-NZt2TCd-IVcrBQOEAS4iyx3eSD4II_ZDeKUzsQaqqZEywzt16Rs7JHRfvjsBPtXlgR8XrLlwoR-NQzvbHmV_9HTjj-mEB00v3Qyf2EGxCTqaMA9qzfizHSH7CQEJ50mgTDABsBP6Z5TUTc7UgPFcakXBzZwvo0Cw4WTOsJKFsqu_hoWoSsqFCkF4K9sCtAcZ-qn8KKznj5-CkMvCg.8ZI-GDr0HgyPBTdNcrXCWSwpvlyLSrOLfCsHHCzxVZE&dib_tag=se&keywords=12v%2Badapter%2Bhigh%2Bwattage&qid=1739403488&sprefix=12v%2Badapter%2Bhigh%2Bwattage%2Caps%2C91&sr=8-2-spons&sp_csd=d2lkZ2V0TmFtZT1zcF9hdGY&th=1