

# ECE 445 - Spring 2025

## Design Document

Antweight Battlebot

Team 2

Nandika Vuyyuri (vuyyuri2), Gauthami Yenne (gyenne2), Jingyu Kang  
(jingyuk2)

TA: Haocheng Bill Yang

# Table Of Contents:

1. Introduction
  - 1.1. Problem
  - 1.2. Solution
  - 1.3. Visual Aid
  - 1.4. High-Level Requirements
2. Design
  - 2.1. Block Diagram
  - 2.2. Physical Design
  - 2.3. Subsystem
    - 2.3.1. Power Subsystem
    - 2.3.2. Communications Subsystem
    - 2.3.3. Control Subsystem
    - 2.3.4. Weapon Subsystem
    - 2.3.5. Drivetrain Subsystem
    - 2.3.6. Sensor Subsystem
    - 2.3.7. PCB Design
  - 2.4. Tolerance Analysis
    - 2.4.1. Weight Analysis
    - 2.4.2. Power Consumption Analysis
3. Cost and Schedule
4. Ethics and Safety
5. References

# 1. Introduction

## 1.1. Problem

This project aims to create an antweight battlebot that would weigh less than 2 lbs to participate in the Antweight Battlebot Competition. The criteria given are that all robots must have visible and controlled mobility such as rolling, non-wheeled, shuffling, or other methods; must be controlled via either Bluetooth or WIFI using a microcontroller with a manual operation for disconnection; and mounted with an attacking mechanism which would contact the arena 5 inches above the ground level and could come to a complete stop within 60 seconds.

## 1.2. Solution

The battle bot will have a tombstone-style horizontal spinning weapon that disables opponents by striking with high-speed impacts. We will use the Emax RS2205 2600KV brushless motor for the weapon, utilizing its high RPM and strong striking force. The weapon will be controlled by an ESP32-C3 microcontroller and operated through user input via Wi-Fi or Bluetooth.

The battle bot will use Greartisan DC 3V 19RPM N20 High Torque Speed Reduction Motor, controlled by a DRV8833 motor driver, for smooth maneuvering. We will use a Thunder Power 325mAh 3S battery to provide efficient power while keeping the design lightweight. The microcontroller will control mobility and weapon activation to ensure precise control. The design will focus on precise control, durability, and optimized weapon operation while maintaining a lightweight frame within the 2-pound limit.

### 1.3. Visual Aid

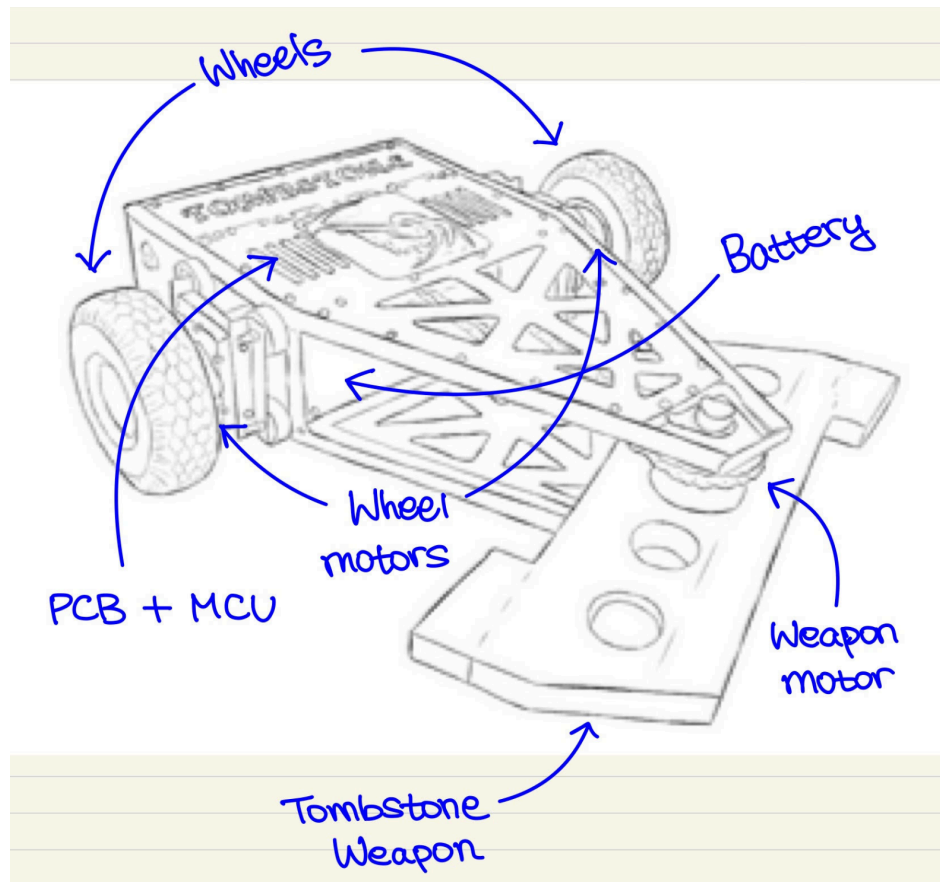

We plan to use a tombstone weapon mechanism like the visual aid above and the Nintendo GameCube Controller to control the battle bot through microcontrollers, ESP32.

### 1.4. High-Level Requirements

- Proper wireless communication must be established for communication between the battlebot and joystick controller with accurate control of speed and direction from controller input (Gamecube controller / Android application).
- The speed of the attacking mechanism, tombstone, will have multiple speed options for blade rotation. Enough power from the battery as well as control of the voltage regulator and motor control would be essential for controlling the speed of the blade. We expect to have 3 options for the speed of blade rotation.
- The battlebot's weapon system and movements should operate properly while maintaining structural integrity at 500+ rpm.
- The total weight of the battlebot should not exceed 2 lbs. Therefore, the backbone of the battle bot will be obtained from a 3D printer using low-weight material PET-G as well as other low-weight components, at the same time be powered during the entire battle duration.

# 2. Design

## 2.1. Block Diagram

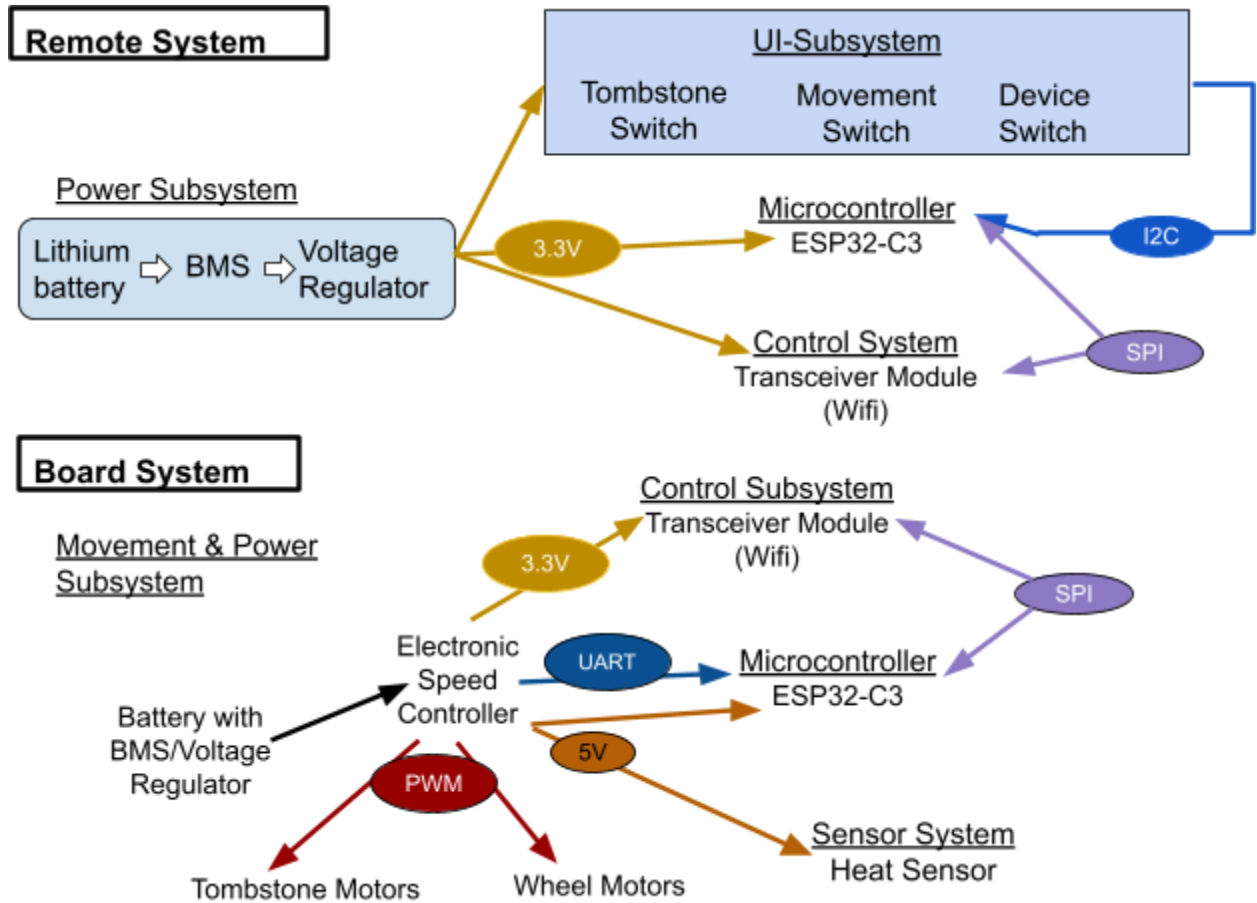

## 2.2. Physical Design of Robot

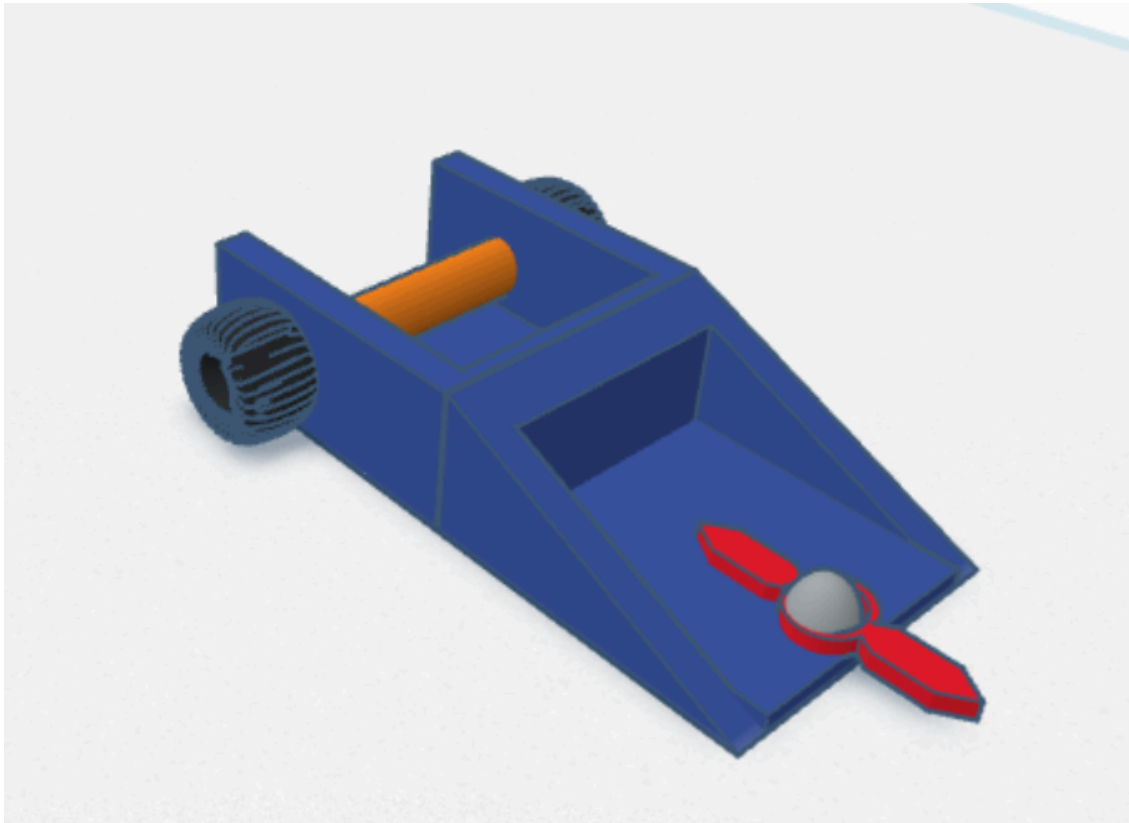

Current CAD drawing for 3D printed battlebot

## 2.3. Subsystem

### 2.3.1. Power System

#### Overview:

The Power System includes the Lithium-Ion battery and the voltage regulators which is a part of the development kit. The voltage regulators are necessary as they provide adequate voltage to various components in the system. ESP32-C requires 3.3V to operate correctly, the DRV8833 motor driver needs a maximum of 5V, and the motors require at least 5 volts. Without the regulators, these components may be exposed to voltages that exceed requirements and may lead to damage. The Thunder Power 325 mAh 3S Battery is a 3-cell lithium polymer battery providing 11.1 nominal voltage. Its maximum continuous discharge is 70C, and its maximum continuous current is 22.75A (capacitance  $\times 325\text{mAh}$  times discharge). The ESP32-C3 requires 3.3 Volts, and the DevKit we are using has a voltage regulator that can take up to 5V input and step it down to 3.3V, however, the battery exceeds that so we will require an additional voltage step-down converter to bring 11.1 V to

5 volts before connecting it to ESP32-C3. The 22.75 A max continuous current is more than enough for the microcontroller, motor driver, and hopefully another voltage regulator.



Thunder Power 325 mAh 3S Battery

Requirements	Validation
Voltage must be stepped down to 5 volts	Use a voltmeter to verify the voltage is within range
Voltage must be stepped down to 3.3 volts from 5 volts	Use a voltmeter to verify the voltage is within range
The power subsystem must be able to supply at least 500 mA to the rest of the system continuously at 5 volts $\pm 0.1V$	Measure and monitor the output current and voltage using multimeter to confirm the power supply remains stable
The battery provides 11.1 V with a continuous discharge of 22.75A, ensuring sufficient power for the entire system	Verify battery output voltage under load conditions using a multimeter and measure current draw to confirm it meets requirements
Extra circuit for Emax brushless motor should be mounted in order to support its 12 Volts input requirement	The voltage supplied from the circuit into the Emax brushless motor will be measured using voltmeter
The battlebot should be able to have enough power and constant current supply for the duration of the battle.	The current of driver motors will be measured with voltmeter in order to check for depletion throughout the movements as well as the remaining battery source.
The power subsystem must be able to supply at least 500mA continuously at 5V $\pm 0.1V$	Measure and monitor the output current and voltage using a multimeter
Decoupling capacitors must be placed near the ESP32-C3 power pins to reduce noise	Use an oscilloscope to check for stable voltage signals

and voltage fluctuations	
The motor driver requires 2.7-10.8 volts and requires up to 1A per channel (2A total)	Measure input voltage and current draw with multimeter to verify
Two DC gear motors require 150mA (300 mA total) under load	Power the motors and measure current draw with a multimeter

### 2.3.2. Communications Subsystem

#### Overview:

The communication system would be in charge of handling communication between the microcontroller and motor drivers, as well as communication between the microcontroller of the remote controller and the battlebot. The microcontroller has Bluetooth/WiFi feature, which would allow the two microcontrollers to communicate with each other. The battery and motors which are controlled by the electronic speed controller will communicate with the microcontroller on the board system using the UART cable and switches on the remote controller for the tombstone and movement as well as the power will communicate with the microcontroller on the remote system through the I2C cable.

Requirements	Validation
The communication subsystem shall enable reliable bi-directional communication between the battlebot microcontroller and the remote controller	Perform range and latency tests for both bluetooth/wifi connections and measure response time
The communication system shall handle motor control signals via UART and switch inputs via I2C without significant latency (under 20 ms)	Use an oscilloscope to measure signal propagation delay from switch automation to motor driver response
The bluetooth module shall be provided a stable 3.3 V (+2%) from the power subsystem	Use a multimeter and oscilloscope to confirm voltage stability
The remote controller shall continuously send control signals at a refresh rate of at least 50Hz to ensure real-time responsiveness	Measure transmission rate using a logic analyzer
The motor controller shall receive real-time	Send test commands over UART and



speed and direction data from the microcontroller via UART communication	confirm the motor driver response using an oscilloscope or serial monitor
The UART communication baud rate shall be 115200 bps or higher to minimize command delay	Check UART baud rate settings in firmware and monitor transmission speed
The I2C protocol shall be used to transmit switch inputs from the remote controller to the microcontroller	Monitor I2C bus traffic with a logic analyzer to confirm correct switch states

### 2.3.3. Control Subsystem

Overview:

The ESP32-C3 is the central control unit for the battlebot. It provides wireless communication between the robot and the user controller. It will receive commands via Wifi or Bluetooth and translate them into control signals for the robot’s function. It will send the control signals to the DRV8833 motor driver which is the drive control and the Emax RS2205 which is the motor used as the attacking mechanism.

ESP32-C3-DevKitM-1 

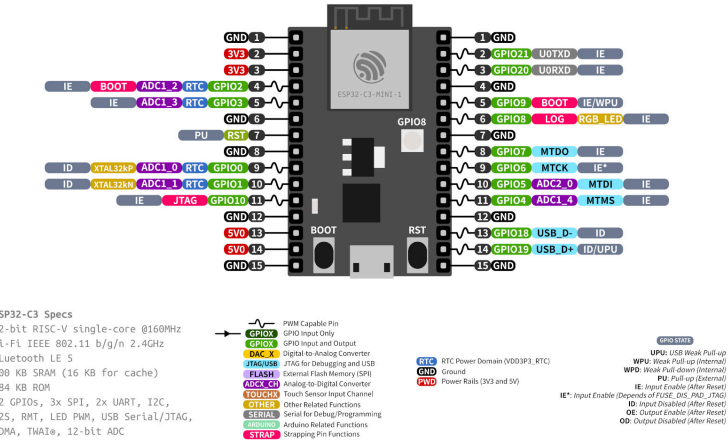

### ESP32-C3

Requirements	Validation
Microcontroller requires 3.3V stable voltage to operate	Measure and monitor the voltage supplied to the ESP32-C3 to ensure it remains at 3.3V +- 5%

ESP32-C3 needs wireless communication through Wifi to receive user commands	Test wifi with the user controller and send/receive data to confirm successful communication.
ESP32-C3 must send control signals to the DRV8833 motor driver for robot movement	Observe the motor driver's response to ESP32-C3 signals, ensuring correct PWM signals are received
ESP32-C3 must send control signals to the Emax RS2205 motor driver for robot movement	Measure the signal output using an oscilloscope to ensure correct PWM signal generation for motor activation

### 2.3.4. Weapon Subsystem

Overview:

For our attacking mechanism, we plan to use the Emax RS2205 2600KV brushless motor, which is known for its high-speed rpm. This motor is usually used for drones, but we plan to repurpose it as a spinning weapon for the battle bot. It will receive power from a battery and be controlled by the ESP32 to determine when and at what speed to spin.



Emax RS2205 2600KV brushless motor

Requirements	Validation
The motor must respond to on/off control signals from the ESP32-C3.	Use an oscilloscope to check the PWM signal from the ESP32-C3 and confirm the motor responds accordingly..
The motor needs to get power from the battery to function without fluctuating power	We can test power delivery using a current sensor to ensure stable and sufficient current flow from the battery.
The motor needs to be attached to the robot properly such that the high-speed spinning does not destabilize the motor	We will perform a mechanical stress test by running the motor at the highest speed we want and checking for mounting failure
The motor should not overheat from the	We will use the temperature sensor to

stress	ensure the safety of the motor and robot.
The speed of battlebot motor should be able to adjust precisely depending on the control input	The average and top speed of the robot will be measured with a phone application. Also, the speed levels will be determined and measured in order to verify constant speed at each level.

### 2.3.5. Drivetrain Subsystem

#### Overview:

The drivetrain subsystem will consist of a four-wheel drive system that operates similarly to a RC car steering system using two electronic speed controllers. The subsystem takes input from the microcontroller as a PWM signal with precise width in order to direct the motor speed as well as the direction. The 3.3-volt signal will be shifted up to a 5 Volts signal, which is the suitable range for the motor. The pulse widths will be determined by specs from the ESC.

The converted modulated power from ESC will be sent to Greartisan DC 3V 19RPM N20 High Torque Speed Reduction Motors, which is controlled by the DRV8833 motor driver. The dual H-bridge configuration of DRV8833 enables independent control of speed and directions.

Initially, four 48mm ABS rubber Mecanum wheels will be used, for the benefit of it being an omnidirectional wheel. Moreover, its smooth connection to the motor would minimize the friction, optimizing the power supplied from the power subsystem. Depending on its compatibility with our battlebot, we are considering switching to our self-designed 3D printed wheels if needed due to its size and weight limitations.

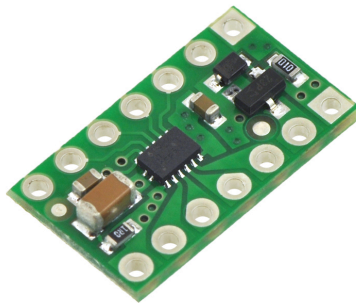

DRV8833 motor driver.



Greartisan DC 3V 19RPM N20 High Torque Speed Reduction Motor

Requirements	Validation
The battlebot should be able to move with a minimum speed of $1.5 \text{ m/s}^2$ .	The average and top speed of the robot will be measured with a phone application.
The movement of the battlebot should not interfere with the weapon subsystem while they are functioning together.	The controller should be able to control the direction and speed of the battlebot and the speed of the weapon precisely at the same time.
The input voltage from the battery should be successfully converted to the suitable power for the motor drivers.	The voltage supplied in and out of the motor drivers will be measured using a voltmeter when it is powered.

### 2.3.6. Sensor Subsystem

#### Overview:

The sensor subsystem is responsible for monitoring the temperature of the tombstone blade rotation to prevent overheating. A LM335AH temperature sensor will be used to track heat levels and ensure the safety of the attacking mechanism. The sensor will trigger a warning if temperatures exceed  $80^\circ\text{C}$ , preventing damage to the battle bot's 3D-printed backbone materials.



## LM335AH Temperature Sensor

Requirements	Validation
The sensor must accurately measure the weapon system's temperature.	We can use an infrared thermometer to measure the temperature to test.
The sensor must trigger a warning if the temperature is above 80 degrees Celsius.	We can simulate high temperatures to see if the warning is triggered.

### 2.3.7. PCB Design

The custom PCB will integrate key components of the battlebot to minimize wiring complexity, improve reliability, and optimize space efficiency. The PCB will include:

- ESP32-C3 microcontroller footprint: To directly mount the ESP32-C3 and handle signal processing.
- Voltage regulation circuit: A step-down DC-DC converter to provide 5V for the motor driver and a 3.3V regulator for the microcontroller.
- Motor driver integration: Connections for the DRV8833 motor driver to control the Greartisan DC 3V 19RPM N20 High Torque Speed Reduction Motor.
- Weapon motor control: A dedicated circuit to manage the high-speed brushless motor using an ESC (Electronic Speed Controller).
- I2C and UART interfaces: To facilitate communication between sensors, motor controllers, and remote input signals.

## 2.4. Tolerance Analysis

### 2.4.1. Weight Analysis

One aspect that could pose a huge risk to the completion of the project is the battery we decided to use. We are using the THP 325-3SR70J, which is 35g. As the key problem is to make the battle bot under 2 lbs, this battery could be a huge problem as it takes a significant portion of the allotted 2 lbs. With this as a major criterion, we would have to make changes to the power system if needed as well. To ensure sufficient power for the system, we have decided to use two THP 325-3SR70J batteries in parallel. This will provide additional power capacity, ensuring stable voltage levels during peak loads. Another consideration would be the weight of the motors. The Greartisan DC 3V 19RPM N20 High Torque Speed Reduction Motor has significantly higher torque despite its heavier weight. This would result in a more powerful and faster battlebot, which leads to cutting weight on

frame weight or elsewhere. Using this motor would also allow more precise speed control and control the speed of the tombstone attacking mechanism.

Mathematical analysis:

- Emax RS2205 2600KV: 29 grams
- ESP-32 Dev Kit: 28.34952 grams
- THP 325-3SR70J Battery (x2): 70 grams
- Greartisan DC 3V 19RPM N20 High Torque Speed Reduction Motor: 9 grams
- DRV8833 Motor Driver Board: 1.5 grams
- 3 wheels: 210 grams
- LM335AH: 0.3 grams
- Estimation for 3D printed parts: 200 grams

Total Weight: 583.15 grams

Weight Limit: 907.185 grams

Our estimated total weight is 583.15 grams, well within the 907.185g limit, providing flexibility for minor design adjustments.

## 2.4.2 Power Consumption Analysis

To ensure efficient operation, we analyzed the power needs of each subsystem.

- Weapon System: The Emax RS2205 motor requires 11.1V and draws up to 25A, consuming a maximum of 277.5W, but typically around 150W.
- Mobility System: The Greartisan DC 3V 19RPM N20 High Torque Speed Reduction Motor operates at 3V, consuming from 0.09W to 0.3W under normal use and 3W at peak stall conditions.
- Control System (ESP32-C3 & Peripherals): Runs on 3.3V, drawing 0.25A, consuming 0.825W.
- Motor Driver (DRV8833): Requires 5V and consumes up to 5W.
- Sensor System (LM335AH Temperature Sensor): Negligible power consumption (0.0005W).

Total Estimated Power Consumption:

- Normal Operation: 178W
- Peak Load: 357W

Power Supply Feasibility with Two Batteries

- Batteries Used: Two THP 325-3SR70J (3S LiPo, 11.1V, 22.75A each)
- Total Available Power: 504.4W
- Conclusion: Both normal and peak power requirements are met, ensuring stable operation without voltage drops.

# 3. Cost and Schedule

## 3.1. Cost Analysis

Labor :

- Estimated at \$30/hour per team member
- Software - 20 hours
- Electrical Design - 40 hours
- Mechanical Design - 20 hours
- $(\$30 \times 80 \text{ hours}) \times 3 \text{ members} = \$7200$

Parts :

Description	Manufacturer	Part #	Quantity	Cost	Total Cost
ESP32-C3	Espressif	DevKitM-1	1	\$12.49	\$12.49
Emax RS2205 Motor	Emax	RS2205	1	\$28.52	\$28.52
DRV8833 Motor Driver	Texas Instruments	DRV8833	1	\$6.99	\$6.99
Thunder Power Battery	Thunder Power	TP325-3 SR70J	2	\$20.99	\$41.98
Greartisan DC 12V 100RPM	Greartisan	N20	2	\$11.99	\$23.98
Mecanum Wheel	Hyduo	Hyduokt budiczay1 241-12	4	\$4.38	\$17.52
LM335AH Sensor	Texas Instruments	LM335AH	1	\$0.68	\$0.68
3-D Printing/Wiring	N/A	N/A	N/A	\$15	\$15
Total Cost					\$147.16

Schedule :

Week	Task
3/10	Finalize the first trial of the PCB design, ensuring all necessary circuit components are correctly placed. Complete the mobility system of the robot, including motor control, sensor integration, and basic movement testing. Begin preliminary debugging of mobility issues.
3/17	Conduct initial testing on the PCB trial #1, identifying issues with power distribution, signal integrity, and communication. Make necessary revisions based on test results. Continue refining robot mobility and responsiveness. Prepare preliminary documentation for midterm evaluation.
3/24	Finalize the tombstone function (movement mechanism, weight distribution, stability testing). Print and assemble the first trial of the robot's physical structure. Begin integration of the structure with electronics and mobility components. Test overall system stability and basic functionality.
3/31	Finalize the Final PCB design with necessary adjustments based on trial #1 feedback. Send the design for manufacturing. Perform software and firmware debugging while awaiting PCB arrival. Refine mechanical structure if needed.
4/7	Integrate all system components: final PCB, robot structure, sensors, and software control. Conduct full-system testing, including power-on diagnostics, sensor accuracy, and motion reliability. Begin stress testing and identifying failure points. Prepare for the final demonstration.
4/14	Make final adjustments to both hardware and software. Ensure the robustness and reliability of the system. Conduct full-scale demo rehearsals and troubleshoot potential presentation/demo issues. Finalize poster and report submission. Practice Final Presentation & Demo for ECE 445.



## 4. Ethics and Safety

### 4.1. IEEE Code of Ethics #1: Safety

Safety is a critical aspect of our battle bot's design, ensuring the well-being of operators, spectators, and the surrounding environment. We will take proactive measures to ensure the bot operates in a controlled and secure environment, minimizing potential hazards.

Key Safety Considerations:

- 1) **Battery Safety (LiPo Batteries):** We will follow strict charging and discharging procedures to prevent overcharging, overheating, or potential battery fires. Batteries will be stored in fireproof containers when not in use. Regular inspections will be performed to check for swelling or damage, and damaged batteries will be disposed of safely.
- 2) **Motor Safety:** High-speed motors pose a risk if improperly handled. To mitigate risks, we will install protective motor covers to prevent accidental activation. A kill switch will be implemented to immediately disable motor movement if an emergency arises. During maintenance, we will ensure motors are completely powered off before any physical interaction.
- 3) **Physical Safety Measures:** The bot will be tested in a designated testing area with appropriate barriers to protect spectators. We will ensure stability in the bot's structure to prevent unintentional tipping or unpredictable movement. Sharp edges or exposed components will be covered or enclosed to reduce injury risks.

By adhering to these safety guidelines, we will minimize risks and ensure that our battle bot operates responsibly and securely.

### 4.2. IEEE Code of Ethics #9: Privacy and Security Concerns

Given that our battle bot relies on Wi-Fi connectivity, it is crucial to implement robust security measures to prevent unauthorized access and ensure operator-only control.

Security Measures Implemented:

- 1) **Secure Authentication for the ESP32-C3:** We will implement password-protected authentication to ensure that only authorized users can control the bot. If possible, we will use encryption protocols (such as WPA2 for Wi-Fi) to protect data transmission from interception.

- 2) Protection Against Unauthorized Access: The system will reject commands from unknown devices, preventing hacking attempts. We will monitor and log access attempts to detect and mitigate security breaches.

By addressing these security concerns, we ensure that the bot operates in a safe, controlled, and private manner without risk of external interference.

### 4.3. ACM Code of Ethics 2.2: Fair Competition

To uphold fair competition standards, we will strictly comply with all rules and regulations set by the competition organizers. Ethical participation ensures fairness, integrity, and a level playing field for all competitors.

Fair Competition Commitments:

- 1) Adherence to Competition Guidelines: We will carefully review and follow the competition's official rulebook, ensuring all design and operational aspects comply with event policies.
- 2) Respect for Other Competitors: We will not engage in any sabotage, interference, or unethical conduct toward other participants. If a dispute arises, we will address it through proper channels rather than through unsportsmanlike behavior.
- 3) Transparency in Design and Performance: We will honestly report our bot's capabilities and limitations without falsifying data or performance metrics. All test results and competition performances will be documented and reported accurately.

By following these ethical standards, we will ensure that our participation is honest, respectful, and in the spirit of fair competition.

## 5. References

- [1]“ESP32C3 Series Datasheet UltraLowPower SoC with RISC-V SingleCore CPU Supporting IEEE 802.11b/g/n (2.4 GHz WiFi) and Bluetooth ® 5 (LE) Including.” Available: [https://www.espressif.com/sites/default/files/documentation/esp32-c3\\_datasheet\\_en.pdf](https://www.espressif.com/sites/default/files/documentation/esp32-c3_datasheet_en.pdf)
- [2]Thunder Power RC, “Thunder Power RC,” *Thunder Power RC*, 2019. <https://www.thunderpowerrc.com/products/tp325-3sr70j> (accessed Mar. 06, 2025).
- [3]ESPRESSIF, “ESP32-C3-DevKitM-1 - ESP32-C3 - — ESP-IDF Programming Guide v5.0 documentation,” *Espressif.com*, 2016. <https://docs.espressif.com/projects/esp-idf/en/v5.0/esp32c3/hw-reference/esp32c3/user-guide-devkitm-1.html> (accessed Mar. 06, 2025).
- [4]DrUAV, “4PCS Emax RS2205 2300KV 2600KV 2205 CW/CCW 3-4S Brushless Motor for RC FPV Racing Drone Quad Motor FPV Multicopter With Box,” *Dr.UAV*. [https://druav.com/products/4pcs-emax-rs2205-2300kv-2600kv?variant=49281606582485&country=US&currency=USD&utm\\_medium=product\\_sync&utm\\_source=google&utm\\_content=sag\\_organic&utm\\_campaign=sag\\_organic&gad\\_source=1&gclid=CjwKCAiAh6y9BhBREiwApBLHC24JyV\\_lzqQbjjeo0NuXc5qmwhL8mpw\\_yISX2KHZv3LGWYs7LA8HfhoCELQQA\\_vD\\_BwE](https://druav.com/products/4pcs-emax-rs2205-2300kv-2600kv?variant=49281606582485&country=US&currency=USD&utm_medium=product_sync&utm_source=google&utm_content=sag_organic&utm_campaign=sag_organic&gad_source=1&gclid=CjwKCAiAh6y9BhBREiwApBLHC24JyV_lzqQbjjeo0NuXc5qmwhL8mpw_yISX2KHZv3LGWYs7LA8HfhoCELQQA_vD_BwE)
- [5]Texas Instruments, “DRV8833 Dual H-Bridge Motor Driver,” *Texas Instruments*. [https://www.ti.com/lit/ds/symlink/drv8833.pdf?ts=1739085202074&ref\\_url=https%253A%252F%252Fwww.google.com%252F](https://www.ti.com/lit/ds/symlink/drv8833.pdf?ts=1739085202074&ref_url=https%253A%252F%252Fwww.google.com%252F)
- [6]High, “Pololu 99:1 100rpm 25D High Power 12V Geared Motor,” *Technobotsonline.com*, 2025. <https://www.technobotsonline.com/pololu-99-1-100rpm-25d-high-power-12v-geared-motor.html> (accessed Mar. 06, 2025).
- [7]Association for Computing Machinery, “Code Code Code The Code ACM Code of Ethics and Professional Conduct,” *ACM Code of Ethics and Professional Conduct*, 2018, doi: <https://doi.org/10.1145/3274591>.
- [8]IEEE, “IEEE Code of Ethics,” *ieee.org*, Jun. 2020. <https://www.ieee.org/about/corporate/governance/p7-8.html>
- [9]“Blocked,” *Gamestop.com*, 2025. <https://www.gamestop.com/gaming-accessories/controllers/retro/products/nintendo-gamcube-controller-styles-may-vary/122695.html> (accessed Mar. 06, 2025).
- [10]“Reddit - Dive into anything,” *Reddit.com*, 2021. [https://www.reddit.com/r/battlebots/comments/q6udz7/practicing\\_digital\\_art\\_by\\_drawing\\_the\\_robot/](https://www.reddit.com/r/battlebots/comments/q6udz7/practicing_digital_art_by_drawing_the_robot/) (accessed Mar. 06, 2025).