

# **ECE 445**

Fall 2024

Project

## **Proposal**

Dylan Bautista, Malay Rungta, & Zachary Krauter

Section H / September 16, 2024

TA: Dongming Liu

# 1. Introduction

## Problem:

Water pollution from man-made debris, poor waste management, and invasive species threatens aquatic ecosystems and public health. Traditional cleanup methods, such as manual removal or large-scale collection efforts, are often inefficient and labor-intensive. They fail to address the persistent presence of small trash, which can have harmful effects on aquatic habitats. To us, this highlights the need for an automated solution. As environmental concerns continue to grow, there is a pressing need for innovative solutions to protect marine ecosystems.

## Solution:

We propose a robotic system that autonomously skims water surfaces to collect small floating debris within a predefined area. The lightweight robot will float and roam a body of water to collect material in a skimming net for disposal or analysis. It will use GPS and sensors for efficient coverage and steering, allowing for it to return to a set of coordinates for emptying. Additionally, the system will include water quality sensors, specifically a turbidity sensor, to monitor pollution levels. The turbidity sensor will be connected to LED lights to provide real time feedback on water clarity: a green light for normal conditions and a red light for high pollution levels. Our system can be tested in a nearby lake or pool on a small scale to evaluate both its collection capabilities and its ability to provide water quality data.

## Visual Aid:

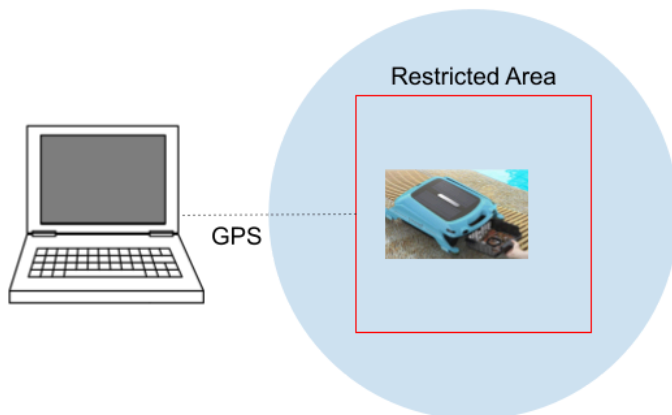

Robot image taken from:

<https://www.smonet.com/keeping-the-perfect-pool-water-level-for-smonet-robot-pool-skimmers-a-detailed-insight/>

## High-Level Requirements List:

1. Autonomous Navigation

The robot must be able to autonomously navigate a predefined water source without crossing boundaries that we will set. It should detect these boundaries using GPS and IMU data with an accuracy of 10 feet to show proper coverage of the water surface.

2. Debris Collection and Return:

The robot must detect and collect floating debris using its skimming net. Every 5 minutes, it should be able to hold and transport at least 250 grams of debris and return to a predefined coordinate with the same accuracy of 12 feet.

3. Water Quality Feedback:

The system must monitor water clarity using a turbidity sensor. Real Time feedback will be provided by LED lights, where green indicates acceptable water quality (the turbidity is below 50 NTU) and red signals unacceptable water quality (the turbidity is above 50 NTU).

<https://www.usgs.gov/special-topics/water-science-school/science/turbidity-and-water>

[https://www.waterboards.ca.gov/water\\_issues/programs/swamp/docs/cwt/guidance/3150en.pdf](https://www.waterboards.ca.gov/water_issues/programs/swamp/docs/cwt/guidance/3150en.pdf)

4. Reach goal: If we have time, we can add pollutant object detection to steer towards floating debris captured via a camera in real time. This would require incorporating an OpenCV Convolutional network into our pre-existing control algorithm. Being able to identify and steer the chassis towards floating trash within 5 feet of the front of the robot would be a stretch goal.

## 2. Design

### Block Diagram:

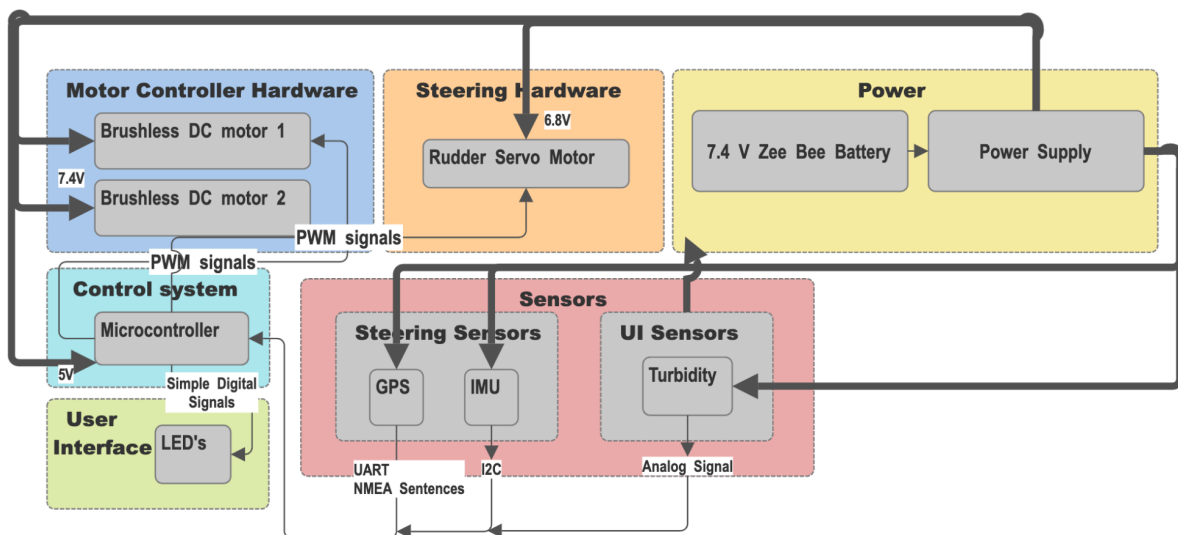

## Block Diagram

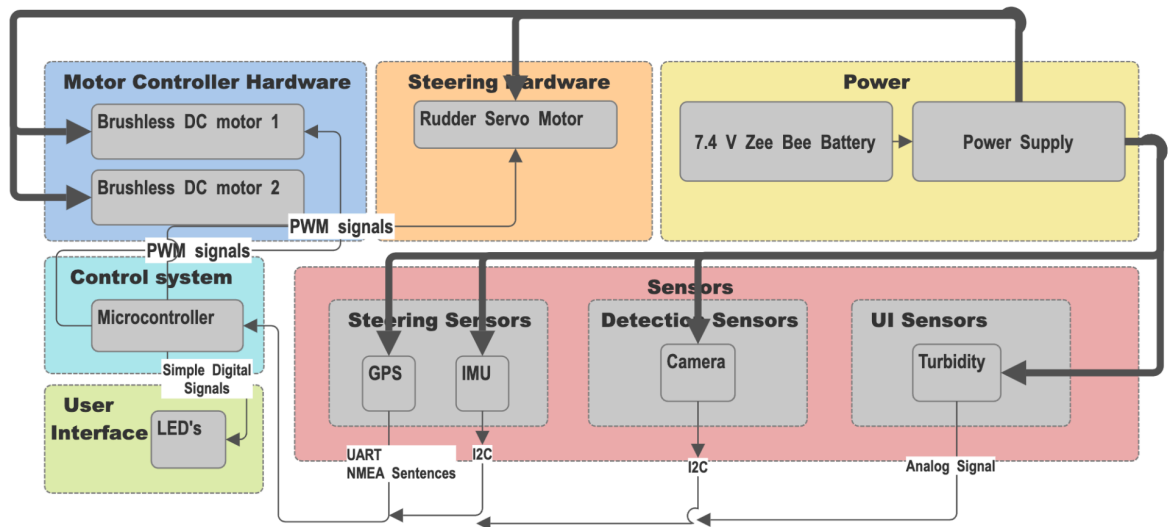

Block Diagram (with reach goal add-ons)

### Subsystem Overview/Requirements:

#### Subsystem 1: Motor Control Hardware

The motor hardware consists of dual brushless DC motors with rotor attachments for water. We have selected the LICHIFIT RC Jet Boat Underwater Motor Thruster 7.4V 16800RPM CW, which should have sufficient torque for our slow-moving purpose. This will be attached to our power system and regulated by our microcontroller through PCB connections.

Requirements:

- Motor control hardware must be able to propel chassis with loaded net at at least ~1mph
- Motors must be able to work within water surface without short circuiting

#### Subsystem 2: Autonomous Steering

The actual steering will be done using a rudder which is moved in place by a servo motor, such as the 13kg RC Boat Model Servo Steering Gear. This will also be attached to the power system and microcontroller. A control algorithm such as bang-bang control, proportional control, or random walk with boundary correction will be implemented much like how an autonomous vacuum cleaner operates. It will be roaming the expanse of its body of water, adjusting the angle to avoid the gps-defined boundaries of the body of water. This will have to use a GPS Module Receiver, Navigation Satellite Positioning NEO-6M, to determine when the front of the robot is nearing these edges. Additionally, after 5 minutes, the robot will return to a specified set of coordinates using its GPS and IMU information in order to dispose of the contents of the net.

Requirements:

- Servo motor must be able to turn in water instantaneously, and keep position while in motion in order to alter the direction of the system
- Software control via the microcontroller must guide system only within bounds of GPS-defined boundary with error of 12 feet

Subsystem 3: Power Systems

The 7.4 V 1500 mAh Zeee battery should be sufficient to run all the sensors, motors, and steering servo. The components will be housed in a waterproof case to protect the electronics from any water damage.

Requirements:

- Power system must be able to supply 1500mAh to the rest of the system continuously at 7.4 V +/- 0.1V

Subsystem 4: Chassis and Storage

The main chassis will be made mostly of 3D printed parts and lightweight materials like PVC pipes and styrofoam. We will use a standard plastic debris net which has an entrance mounted at the end opening of the floating device, with the rest of the net trailing behind.

- Must be able to stay afloat for the duration of the 5 minutes with the weight of the debris it is carrying.

Subsystem 5: Interface Sensor

At minimum, our robotic system will have a turbidity sensor, specifically the TSD-10, to monitor particle content in the water for additional environmental data. This will be connected to our power system and the accompanying microcontroller. The robot will use LED lights to provide visual feedback based on the sensor readings. Green will indicate normal water conditions, and red will indicate water pollution. The sensors will change the lights if turbidity rises above a predefined level of 50 NTU, allowing for immediate detection of changing water quality.

Requirements:

- LED light must be able to instantaneously display a red light given a turbidity reading exceeding an arbitrary water clarity level.

<https://www.amphenol-sensors.com/hubfs/AAS-920-616C-Thermometrics-TSD-10-022724-web.pdf>

### **Tolerance Analysis:**

A crucial aspect of our design is the robot's ability to autonomously navigate without leaving the boundaries. A small error in the GPS or IMU could lead to the robot traveling outside the boundaries. We will need to perform an analysis of the robot's navigation system's tolerance for error so that it can stay within a 12 feet boundary. To make sure this is reliable, we will test the robot's ability to navigate within these tolerances through real-world experiments.

### **3. Ethics and Safety**

There are some ethical considerations related to the development of our Water-Skimming Robot. We will prioritize public safety, working sustainably, and avoiding any harm to aquatic animals. Our robot will minimize disturbance to the wildlife, making sure no animals are trapped in the net during its operation. We will also avoid using harmful materials that can contribute to pollution, so we're being careful about our choices so we avoid creating more waste while we clean up the water.

In terms of safety, our system must follow safety standards to prevent injuries or malfunctions during testing and future use. All electronics will need to be waterproofed to avoid possible short-circuiting, and the battery will need to be managed carefully to avoid overheating. We also need to comply with the regulations regarding the use of remote vehicles on public water bodies, such as those set by the U.S. Coast Guard. We want to make a robot that not only helps clean up the environment but does so in a safe and responsible way.