

Jason Leung/Mike Tu

110/120 Honor's Lab

12/16

## TrakCard Final Report

### I. Introduction

*TrakCard* was designed to be a 24/7 tracking and notification device capable of transmitting important information to a mobile device.

Keeping track of belongings such as credit cards, wallets, and other valuables are often tricky. Finding lost belongings are an even more difficult issue. While there are many existing products that can help locate missing items, *TrakCard* intends to tackle the problem at the source: not losing it. Through bluetooth and a mobile device's gps, *TrakCard* aims to alert users as soon as they are separated from their items.

*TrakCard* will feature a bluetooth module, indicator lights, and an intuitive app for the optimal experience. The key component was a **HC-05** bluetooth low energy communicator. The original design also included an electromagnet intended to temporarily disable the magnetic strip on a credit card. However, the idea was scrapped due to time constraints.

### II. Design

The basis of the design revolves around the communication between the mobile device and *TrakCard*. The circuit will send information to the mobile device through the use of a bluetooth wireless serial communicator. The mobile APP will then process the

data and output/perform tasks. The information is then passed back to the circuit for hardware response. (Appendix A.I)

The HC-05 Diagram shows the set up required for it to be operational. For the TX arduino - RX on the HC-05 not to be damaged, a voltage divider must be used to reduce the voltage that enters. (Appendix A.II)

The code will essentially constantly try to reconnect every clock cycle after its first connection. If the connection breaks, code will run to send a notification to the device as well as a ascii '1'. The arduino will then interpret it and output a digital high to pin 7. (Appendix A.III + IV).

Pin 7 will be AND with a voltage divided photoresistor so the LED will light up when the surroundings are dim. (Appendix A.V)

There is also more code on the APP side which will remember the current GPS location and save it when the *TrakCard* is disconnected. Then a call can be made to display the last connected location on google maps. Unfortunately, an image is unavailable.

### III. Results

The device works as intended to its full extent, with not problems. However, as stated earlier, the electromagnet was scrapped due to time constraints.

### IV. Problems and Challenges

The original plan was to judge signal strength and determine a suitable cut off for notifications. However, obtaining the signal strength was difficult. There were many

nuances and other problems with the serial calls and storing the applicable information and use it after.

A second issue was the notifier. Initially, the notification worked flawlessly after implementation. However, functionality stopped after a certain time on my phone (a Huawei) but still worked on the other phone. A potential reason may be the android update.

Another challenge had nothing to do with implementation, but that there were many broken LEDs in the lab which were not tested. However it was assumed to work and thus took some time to realize that they were broken.

## V. Future Plans

The implementation of the electromagnet will significantly increase the usefulness of *TrakCard*. With the implementation, even if the card is stolen, the magnet will turn on and disable the card immediately.

Shrinking the overall project onto a custom PCB would be another necessary step if *TrakCard* were to be made into a real product.

## VI. References

Buckley, Ian. "6 Easy Ways to Connect Arduino to Android." MakeUseOf, 2 Oct. 2017, [www.makeuseof.com/tag/6-easy-ways-connect-arduino-android/](http://www.makeuseof.com/tag/6-easy-ways-connect-arduino-android/).

"MIT App Inventor." About Us | Explore MIT App Inventor, 3 Dec. 2018, [appinventor.mit.edu/explore/](http://appinventor.mit.edu/explore/).

puravidaapps.com. "App Inventor Extensions." App Inventor Code Snippets | Pura Vida Apps, [puravidaapps.com/notification.php](http://puravidaapps.com/notification.php).

## APPENDIX A

### I. Basic Block Diagram

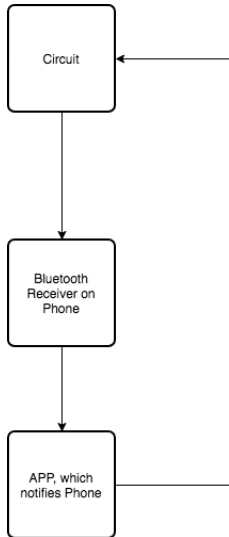

### II. HC-05

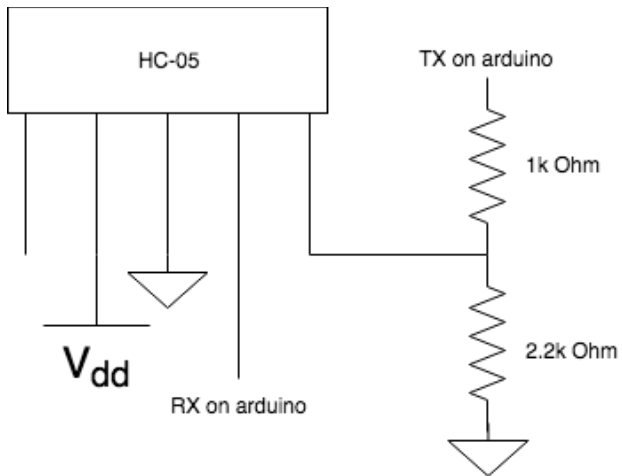

### III. APP code 1

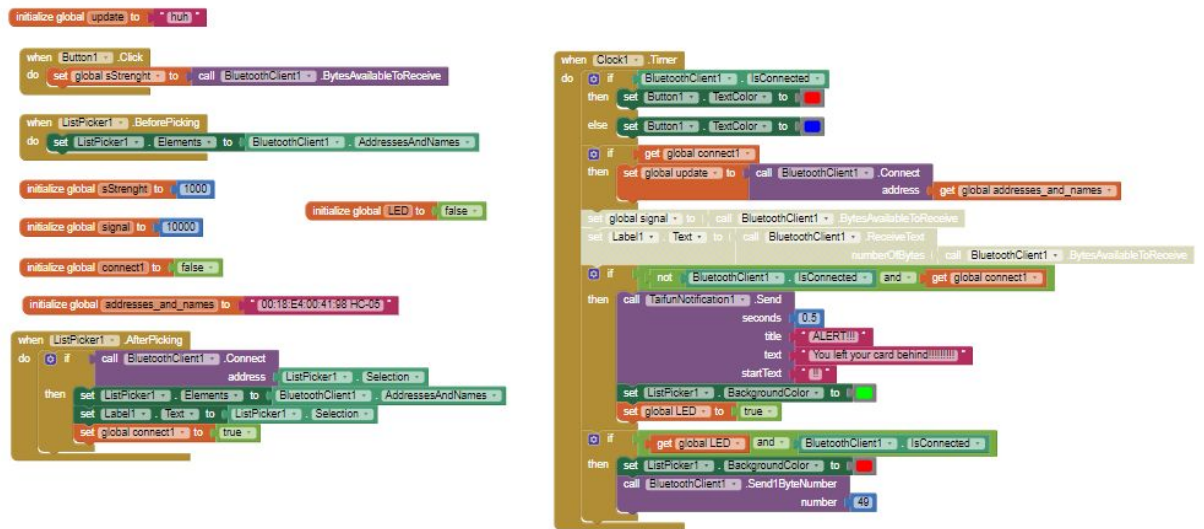

#### IV. Code 2

```

#define led 7
//#include <SoftwareSerial.h>
int state = 0;
//SoftwareSerial mySerial(0, 1);

void setup() {
  pinMode(led, OUTPUT);
  //original serial is 38400
  Serial.begin(9600);
  digitalWrite(led, LOW);
}

void loop() {
  if (Serial.available() > 0) {
    state = Serial.read();
  }
  if (state == '1') {
    digitalWrite(led, HIGH);
    state = 0;
  }
}

```

V. LED

