

Jeel Thakkar – jeelbt2
Jeenal Thakkar – jeenalt2
Anh Leu – anhleu2
12/12/2016

Final Report Honor Section: Bluetooth Tracker

1. Introduction

a. Statement of Purpose

The purpose of this project is to help locate lost valuable items. All of us have lost something very precious (phone, keys, wallet, I-card, and so on) at some point in our life and cried over it. That is why we are working on a solution to track any of those assets. There are all sorts of GPS tracking applications online. However, they all require having a secured WIFI connection on the device. However, WIFI is not accessible everywhere all the time. Therefore, we will try to approach this problem using Bluetooth technology.

b. Features and Benefits

This project is a simple tracking device that allows everyone to track anything within the radius of 100 meters. We use a smartphone with an app to send a certain message to our device. The device will immediately respond by lighting up the LED light and making sound through our buzzer that will recite the message using Morse code based on the message that we used.

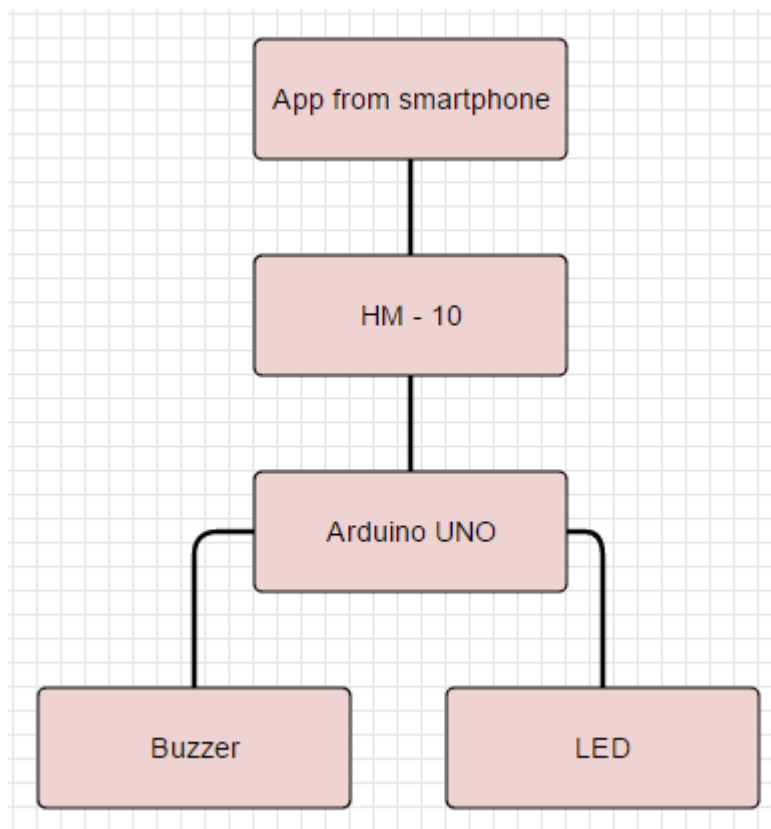

2. Design

a. System Overview

The overall system includes a slave module on the lost device. This circuit includes a HM-10 Bluetooth module, which responds to the smartphone app. This Bluetooth module will accept the message signaled from the app and tell the Arduino to run the code which output the message in Morse code using the LED and the buzzer.

Jeel Thakkar – jeelbt2
Jeenal Thakkar – jeenalt2
Anh Leu – anhleu2
12/12/2016

b. Design Details

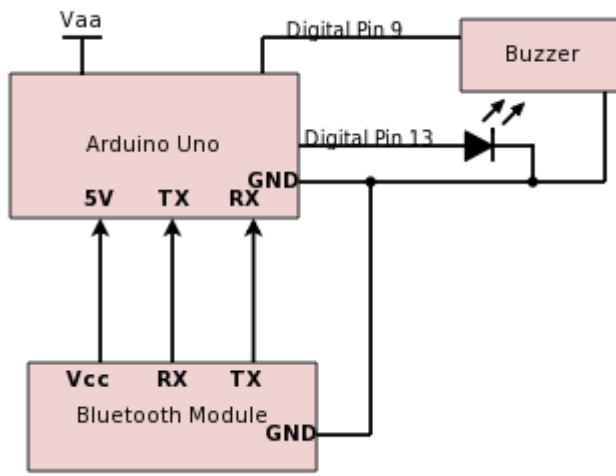

App from the phone

At first, we intended on using two different HM-10 modules. However, after many researches, we realized it was much more complicated to pair the two Bluetooth modules than having one Bluetooth module as the slave and the master will be the smartphone. In modern age, this is the more practical approach. However, this will be a problem for people that do not have a smart phone that can install an app onto it.

HM – 10 Bluetooth Modules

HM-10 Bluetooth module is an energy saving Bluetooth module that is compatible for our purposes and does not consume too much battery power.

Arduino UNO

Arduino includes a code that out output the message that we type in the app in the smart phone. The message will be output in Morse code. This is something we did not plan ahead before. However, this turns out to be an interesting feature that maybe our device can be used for different purposes other than tracking.

Buzzer

The buzzer will receive the signal from the Arduino to output a sound: a long sound for the dash and the short sound for the dot using Morse code. The buzzer is essential for our purposes to notice the owner of the where about of the lost device. However, the buzzer sound is very small and a bit too big for our design.

LED

The buzzer will receive the signal from the Arduino to output the light accordingly, at the same time with the sound from the buzzer. The LED also helps in searching for the lost device using light.

3. Results

The Bluetooth module has the range of 100 m. We conducted tests of the tracking from another room. It responded. However, the buzzer's sound is way too small to hear the sound if you are not in the same room with the tracking device.

Jeel Thakkar – jeelbt2
Jeenal Thakkar – jeenalt2
Anh Leu – anhleu2
12/12/2016

4. Problems and Challenges

The major problem was with getting the right Bluetooth module. We ordered the module without the soldering, which requires the making of a PCB board, which we have not learned to make yet so we had to order new ones. This made us started the project in early November and could not do much.

The second major problem is to learn to pair up the two modules. It is extremely difficult for the two modules to respond. We used many different websites but the module did not respond as expected. Finally, we got the slave module to respond but when we did the same thing to the master module, it did not respond. So around one week after the midterm demo, we decided to switch to using an app and a smart phone to control the module instead of another HM-10 module.

The last major problem is that none of us has experience in making an app before. We found an app making app that can control an LED through Bluetooth but not the buzzer, which is our main purpose. When we tried to reconstruct the app, it kept crashing. Due to time constraint, we could not figure that out in time and was looking through many different app making app. Most of them either use an Android phone (which none of us has) or only works with LED. Finally we found an app that, with little modifications, works the way we wanted. Since there is not much else we could do, we decided to make it interesting by using an Arduino code and output the message in Morse code instead of a usual tune.

5. Future Plans

For future plan, we intend to find a way to make the tracking device much smaller. We can learn to make a PCB Board for the Bluetooth module, and then solder most of the parts together. We will also so research on better buzzer that is more compact in size and output a louder sound. We will use a coin battery instead of our current battery. We can also replace the Arduino with maybe an AT Tiny or a Teensy. Instead of a bulky box as a cover, we can 3D print our cover and make it more user-friendly.

We also realized that the device consume a lot of energy even when not being used so we need to find a solution for that.

Finally, after learning about FSM in this semester, we want to implement that in our project next semester by making different states for the device.

6. References

"Multiwingspan". *Multiwingspan.co.uk*. N.p., 2016. Web. 12 Dec. 2016.

"Tutorial ARDUINO: Uso Del Bluetooth 4.0 Con Un Iphone.". *YouTube*. N.p., 2016. Web. 12 Dec. 2016.

Jeel Thakkar – jeelbt2
Jeenal Thakkar – jeenalt2
Anh Leu – anhleu2
12/12/2016

7. Code Appendix

```
int ledPin = 13; //connect the LED at pin 13

int buzzerPin = 9; //connect the Buzzer at pin 9

String readString;

// tone frequency C

const int tonefreq = 523;

// constants for tone and rest durations

const int dotlength = 100;

const int dashlength = dotlength * 3;

// inter-element gap - between each dot or dash of a letter

const int inter = dotlength;

// letter gap is 3 dots - the inter gap is always added - so this is one fewer

const int lgap = dotlength * 2; // inter-letter gap

// word gap is 7 dots - with letter and inter gap already counted, this is -1

const int wgap = dotlength * 4; //inter-word gap

void setup() {

    Serial.begin(9600);

    pinMode(ledPin, OUTPUT);

    pinMode(buzzerPin, OUTPUT);

}
```

Jeel Thakkar – jeelbt2
Jeenal Thakkar – jeenalt2
Anh Leu – anhleu2
12/12/2016

```
void loop()

{

  char thischar;

  if (Serial.available())

  {

    // read a single character

    thischar = Serial.read();

    if (thischar>='a' && thischar<='z')

    {

      // convert to upper case

      thischar = thischar -32;

    }

    // swap for a space if not in A-Z

    if(thischar<65 || thischar>90)

    {

      thischar=' ';

    }

    soundLetter(thischar);

    delay(lgap);

  }

}

void dot()

{
```

Jeel Thakkar – jeelbt2
Jeenal Thakkar – jeenalt2
Anh Leu – anhleu2
12/12/2016

```
// play a dot
```

```
tone(buzzerPin, tonefreq);
```

```
// LED
```

```
digitalWrite(ledPin, HIGH);
```

```
delay(dotlength);
```

```
noTone(buzzerPin);
```

```
// LED
```

```
digitalWrite(ledPin, LOW);
```

```
delay(inter);
```

```
}
```

```
void dash()
```

```
{
```

```
// play a dash
```

```
tone(buzzerPin, tonefreq);
```

```
// LED
```

```
digitalWrite(ledPin, HIGH);
```

```
delay(dashlength);
```

```
noTone(buzzerPin);
```

```
// LED
```

```
digitalWrite(ledPin, LOW);
```

```
delay(inter);
```

```
}
```

Jeel Thakkar – jeelbt2
Jeenal Thakkar – jeenalt2
Anh Leu – anhleu2
12/12/2016

```
void soundLetter(char letter)
{
    // letters are in order of frequency
    switch(letter)
    {
        case 'E':
            dot();
            return;
        case 'T':
            dash();
            return;
        case 'A':
            dot();
            dash();
            return;
        case 'O':
            dash();
            dash();
            dash();
            return;
        case 'I':
            dot();
```

Jeel Thakkar – jeelbt2
Jeenal Thakkar – jeenalt2
Anh Leu – anhleu2
12/12/2016

dot();

return;

case 'N':

dash();

dot();

return;

case 'S':

dot();

dot();

dot();

return;

case 'H':

dot();

dot();

dot();

dot();

return;

case 'R':

dot();

dash();

dot();

return;

case 'D':

Jeel Thakkar – jeelbt2
Jeenal Thakkar – jeenalt2
Anh Leu – anhleu2
12/12/2016

dash();

dot();

dot();

return;

case 'L':

dot();

dash();

dot();

dot();

return;

case 'C':

dash();

dot();

dash();

dot();

return;

case 'U':

dot();

dot();

dash();

return;

case 'M':

dash();

Jeel Thakkar – jeelbt2
Jeenal Thakkar – jeenalt2
Anh Leu – anhleu2
12/12/2016

dash();

return;

case 'W':

dot();

dash();

dash();

return;

case 'F':

dot();

dot();

dash();

dot();

return;

case 'G':

dash();

dash();

dot();

return;

case 'Y':

dash();

dot();

dash();

dash();

Jeel Thakkar – jeelbt2
Jeenal Thakkar – jeenalt2
Anh Leu – anhleu2
12/12/2016

return;

case 'P':

dot();

dash();

dash();

dot();

return;

case 'B':

dash();

dot();

dot();

dot();

return;

case 'V':

dot();

dot();

dot();

dash();

return;

case 'K':

dash();

dot();

dash();

Jeel Thakkar – jeelbt2
Jeenal Thakkar – jeenalt2
Anh Leu – anhleu2
12/12/2016

return;

case 'J':

dot();

dash();

dash();

dash();

return;

case 'X':

dash();

dot();

dot();

dash();

return;

case 'Q':

dash();

dash();

dot();

dash();

return;

case 'Z':

dash();

dash();

dot();

Jeel Thakkar – jeelbt2

Jeenal Thakkar – jeenalt2

Anh Leu – anhleu2

12/12/2016

dot();

return;

case '':

delay(wgap);

return;

}

}