

Umang Chavan

Jason Hwang

Alan Wang

Prof. Christopher Schmitz

Section AB3

12/06/2015

ECE 110 Honors Lab Report

I. Introduction

- A. How does an electronic speed controller function? How does it create a three-phase voltage output that can control a brushless DC motor?
- B. To understand a basic overview of brushless DC motor control, we built a six-switch circuit on a breadboard to be controlled with an Arduino. The Arduino microcontroller will open and close the six switches of the circuit in a specific sequence and light up LEDs in the same manner that a brushless electronic speed controller would control the polarities of the electromagnet to control the rotation of the motor.

II. Design

Diagram 1: Block Design of ESC Motor Control Circuit

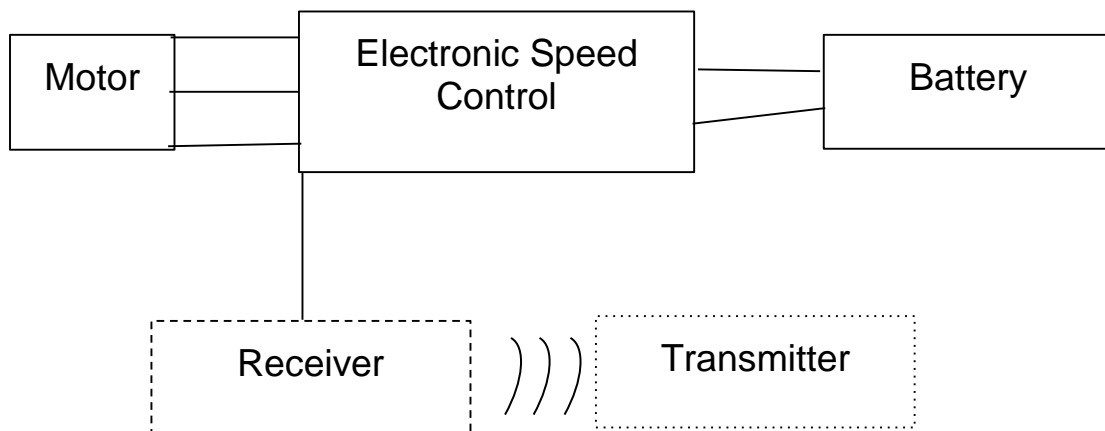

Diagram 1:

This block diagram shows the overall circuit that controls a brushless DC motor. The user controls an output signal with a transmitter, which is detected by the circuit's receiver.

The receiver passes the signal to the electronic speed controller and controls the voltage applied to the motor, hence controlling the motor's speed.

Diagram 2: 6 Switch Arrangement Circuit

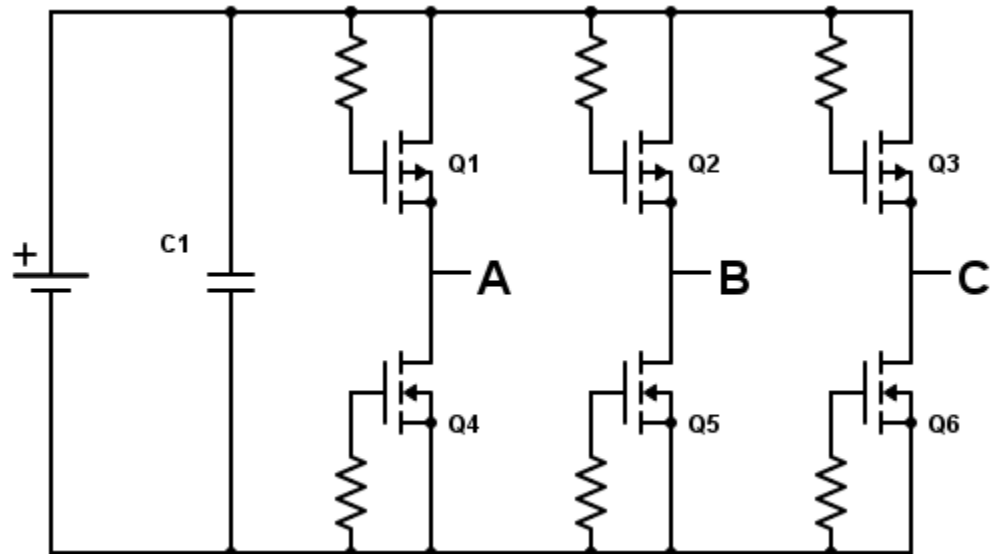

Diagram 2:

This diagram shows the arrangement of the circuit parts on our bread board. A PMOS is placed at Q1, Q2, and Q3, and an NMOS is placed at Q4, Q5, and Q6. These are the gates that control where the current is directed and which light bulb is turned on at a given time. The LEDs are placed at A, B, and C. The arduino will be connected to all PMOSs and NMOSs.

Diagram 3: 3 Phase Voltage Motor Drive Circuit

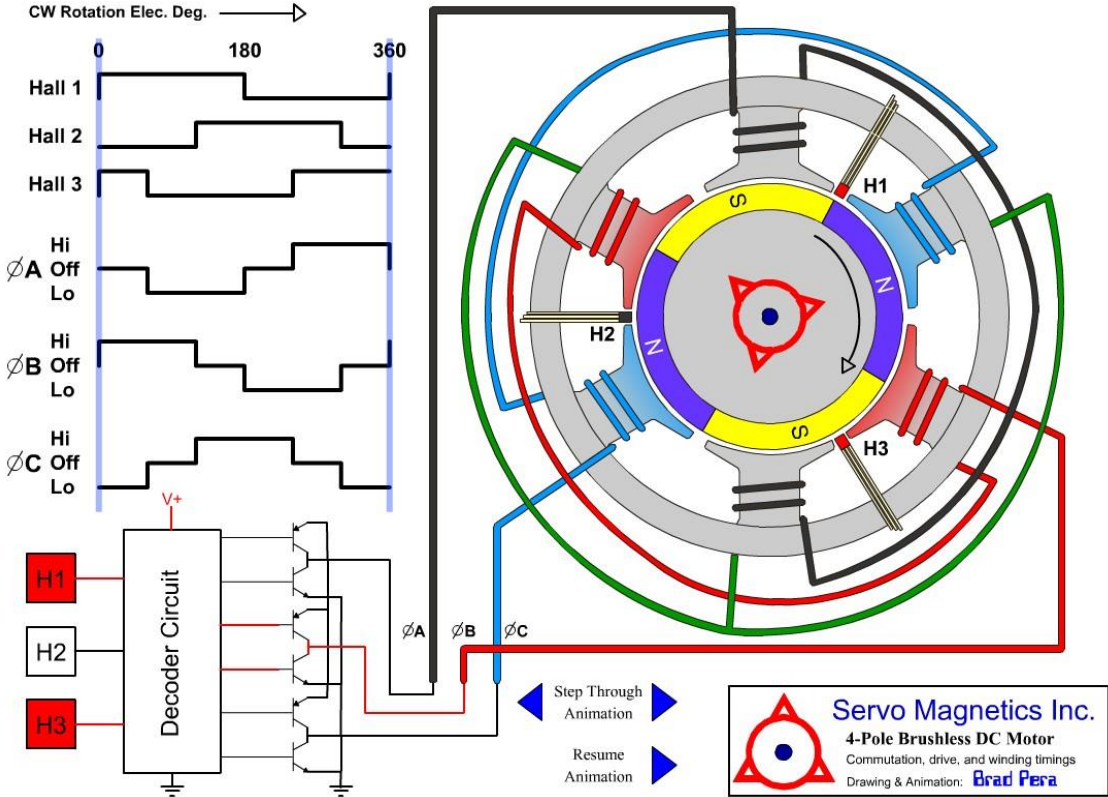

Diagram 3:
 This diagram shows how the logic Hi and logic Lo would influence the movement of the inrunner stator.

Diagram 4: 3 Phase Voltage Frequency Plot

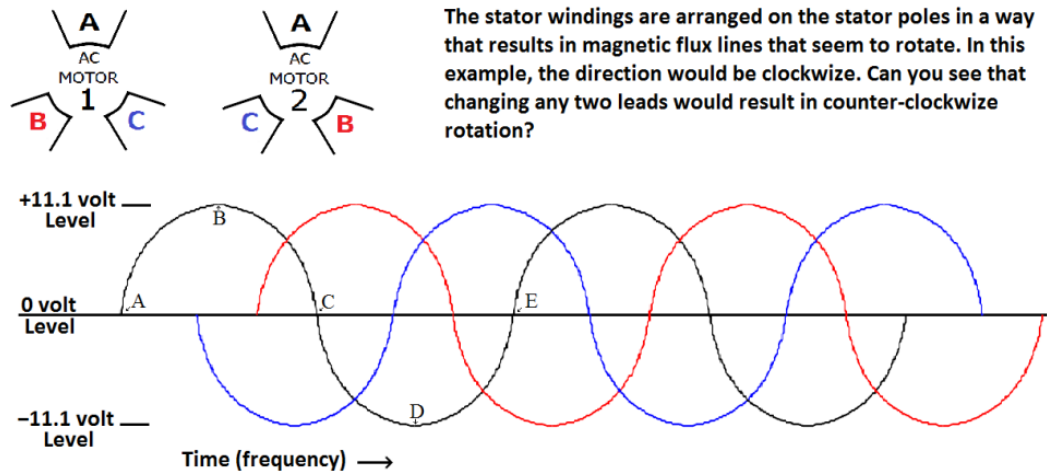

Diagram 4:

This diagram shows the plot of the frequency of the change in the voltage of each electromagnet. The frequencies influence how fast the motor would rotate.

Circuit Pictures:

Arduino Code:

```
const int gate1 = 1;
const int gate2 = 2;
const int gate3 = 3;
const int gate4 = 4;
const int gate5 = 5;
const int gate6 = 6;

const int DELAY = 1000;

void setup() {
  pinMode(gate1, OUTPUT);
  pinMode(gate2, OUTPUT);
  pinMode(gate3, OUTPUT);
  pinMode(gate4, OUTPUT);
  pinMode(gate5, OUTPUT);
  pinMode(gate6, OUTPUT);
```

```
digitalWrite(gate1, HIGH);
digitalWrite(gate2, HIGH);
digitalWrite(gate3, HIGH);
digitalWrite(gate4, LOW);
digitalWrite(gate5, LOW);
digitalWrite(gate6, LOW);
}

void loop() {

digitalWrite(gate3, LOW);
digitalWrite(gate4, HIGH);
delay(DELAY);
digitalWrite(gate3, HIGH);
digitalWrite(gate4, LOW);

digitalWrite(gate1, LOW);
digitalWrite(gate5, HIGH);
delay(DELAY);
digitalWrite(gate1, HIGH);
digitalWrite(gate5, LOW);

digitalWrite(gate2, LOW);
digitalWrite(gate6, HIGH);
delay(DELAY);
digitalWrite(gate2, HIGH);
digitalWrite(gate6, LOW);
}
```

III. Results

A. Results

We were able to successfully able to create a 3-Phase 6 Switch circuit that is similar to those found in electronic speed controllers to control the speed of brushless DC motors. We were successful because we created the circuit successfully and wrote the Arduino code correct, as all three LEDs light up in the correct sequence.

B. Qualitative Analysis

Our circuit was able to make the LEDs light up, and we could change the frequency at which the light bulbs lit up just by changing the time delay. With a smaller delay, we could make the LEDs flash quickly.

C. Quantitative Analysis

The circuit works by a careful opening and closing of specific gates at specific times. For the first phase, we opened gates 3 and 4 so that current would flow into pin C and out through pin B (see circuit schematic above). Since all the pins are connected within the motor through a triangular formation of solenoids (see figure below), two magnetic fields will be created, with opposing north and south poles created at the center. These opposing magnetic fields will drive the central permanent magnet in a clockwise fashion, thus turning the motor 120 degrees. For the second phase, we opened gates 1 and 5 so that current would flow into pin B and out of pin A, so that the poles will switch and the central magnet will rotate another 120 degrees. This process will repeat indefinitely to drive the motor.

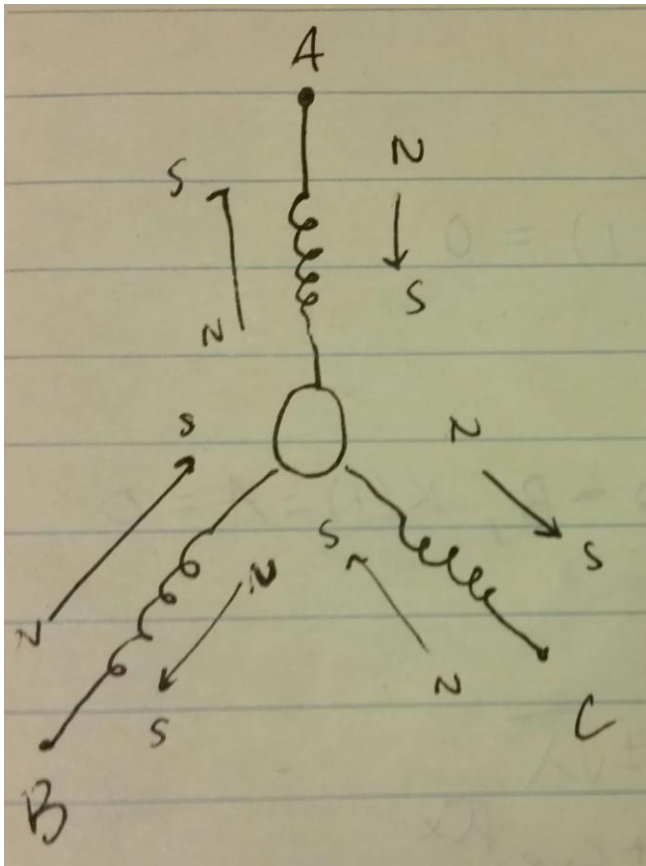

IV. Future Work

A. Next Steps for Project

In the future, we would like to understand a bit more about how some of the other parts of the circuit diagram work. For instance, we would like to explore how the transmitter and receiver communicate and function.

The end goal is to learn as much as we can about the parts of the overall circuit so we could create a fully functional transportation device.

V. Conclusion

A. What Worked

We created a circuit with NMOS's and PMOS's to create a 3-phase signal output, which we displayed with LEDs. In order to switch the gates to High or Low, we created an Arduino code that turned on/off the gates, with a delay of a few seconds. Everything worked as we had hoped.

B. What Didn't Work

At first we had trouble getting the circuit to work. Our two outer LEDs were lighting up, but the middle LED remained off at all times. When we used the oscilloscope to look at our wave, we were getting a reasonable reading, but it was not a clear square wave. Despite that, our middle LED should still have been lighting up, since the oscilloscope reading was consistent with those of the other two LEDs. Eventually, we did find a mistake in our circuit, and we were able to fix that and get the middle LED working.

C. What We Learned

Initially, our project was to further continue working on Jason's project, which was to create rollerblades that could be attached to shoes and could be controlled by a controller. One part of that project included an electronic speed control, which to us at that point, was just a box that had three wires connected to the motor, to get it running. Jason knew a bit about the ESC at the very beginning, but Alan and I did not anything about it. The TA's then suggested that we learn what the ESC does and how it keeps the wheel moving. We learned about the three phase signals that the ESC sends to the motor, which is explained earlier in this report, and we created a circuit that has the same fundamental function as the ESC. The three phases keep changing the polarities of the three magnets in the motor, to drive the motor in a clockwise direction,