

Data Center Networks

Brighten Godfrey
CS 538 April 5 2017

Thanks to Ankit Singla for some slides in this lecture



Introduction: The Driving Trends



Computing as a utility

- Purchase however much you need, whenever you need it
- Service ranges from access to raw (virtual) machines, to higher level: distributed storage, web services

Implications

- Reduces barrier to entry to building large service
 - No need for up-front capital investment
 - No need to plan ahead
- May reduce cost
- Compute and storage becomes more centralized

The physical cloud: Data centers



Facebook data center, North Carolina



National Petascale Computing Facility,
UIUC





Weather Condition	Frequency of Occurrence
ASHRAE 50 Year	Combines worst recorded wetbulb (from 1972 to 2001) along with hottest drybulb in 50 years (these generally do not occur at the same time)
Extreme DB	This state point assumes the drybulb is even higher than worst in 50 years.
ASHRAE 0.4% (Evaporative)	This state point is exceeded only 35.0 hours in a statistically "typical" year
ASHRAE 1% (Evaporative)	This state point is exceeded only 87.6 hours in a statistically "typical" year
ASHRAE 2% (Evaporative)	This state point is exceeded only 175.2 hours in a statistically "typical" year
ASHRAE Winter Peak	This represents 50% RH at the coldest drybulb in 50 years

VITESSE COLD AISLE CRITERIA
65°F TO 80°F DB
41.9°F TO 59.0°F DP
MAX 65% RH

ASHRAE GUIDELINES
64.4°F TO 80.6°F DB
41.9°F TO 59.0°F DP
MAX 60%RH

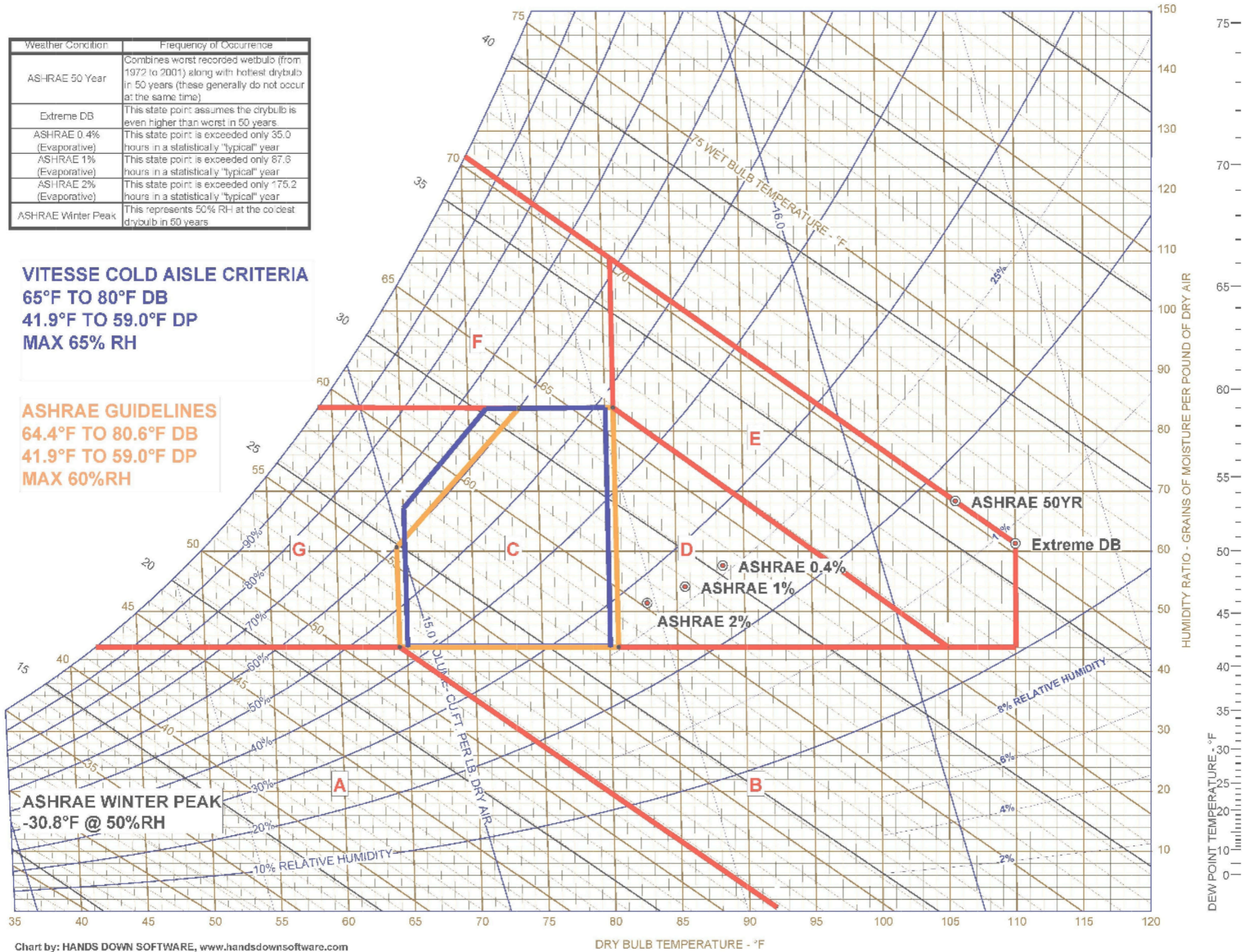

Chart by: HANDS DOWN SOFTWARE, www.handsdownsoftware.com

DRY BULB TEMPERATURE - °F

Key advantage: economy of scale



One technician for each 15,000 servers [Facebook]

Facility / power infrastructure operated in bulk

- Power usage efficiency (PuE) ~ 1.8 in average DCs
- Pushed down to ~ 1.1 in large cloud DCs

Ability to custom-design equipment

- Servers, switches, NICs...

Statistical multiplexing

- Must provision for peak load
- Many users sharing a resource are unlikely to have their peaks all at the same time

Key advantage: economy of scale



Statistical multiplexing

- Must provision for peak load
- Many users sharing a resource are unlikely to have their peaks all at the same time
- Just as in packet switching

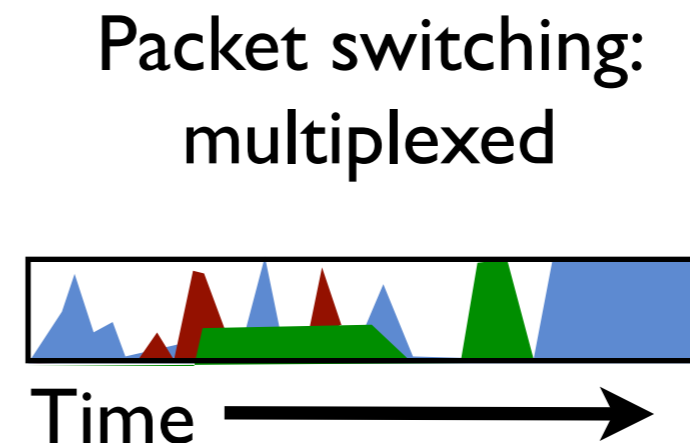
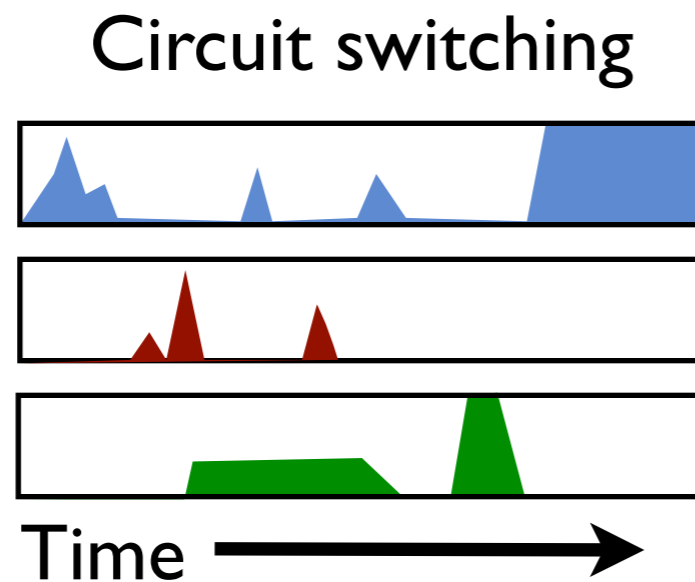



Challenges

- Confidentiality of data and computation
- Isolation of resources
- Integration with existing systems
- Robustness
- Latency
- Bandwidth
- Programmability
- ...

Opportunities

- New systems and architectures
- Optimizations matter

Costs in a data center



Servers are expensive!

Amortized Cost	Component	Sub-Components
~45%	Servers	CPU, memory, storage systems
~25%	Infrastructure	Power distribution and cooling
~15%	Power draw	Electrical utility costs
~15%	Network	Links, transit, equipment

[Greenberg, CCR Jan. 2009]

A key goal: Agility



Agility: Use any server for any service at any time

- Increase utilization of servers
- Reduce costs, increase reliability

What we need [Greenberg, ICDCS'09]

- Rapid installation of service's code
 - Solution: virtual machines
- Access to data from anywhere
 - Solution: distributed filesystems
- Ability to communicate between servers quickly, regardless of where they are in the data center

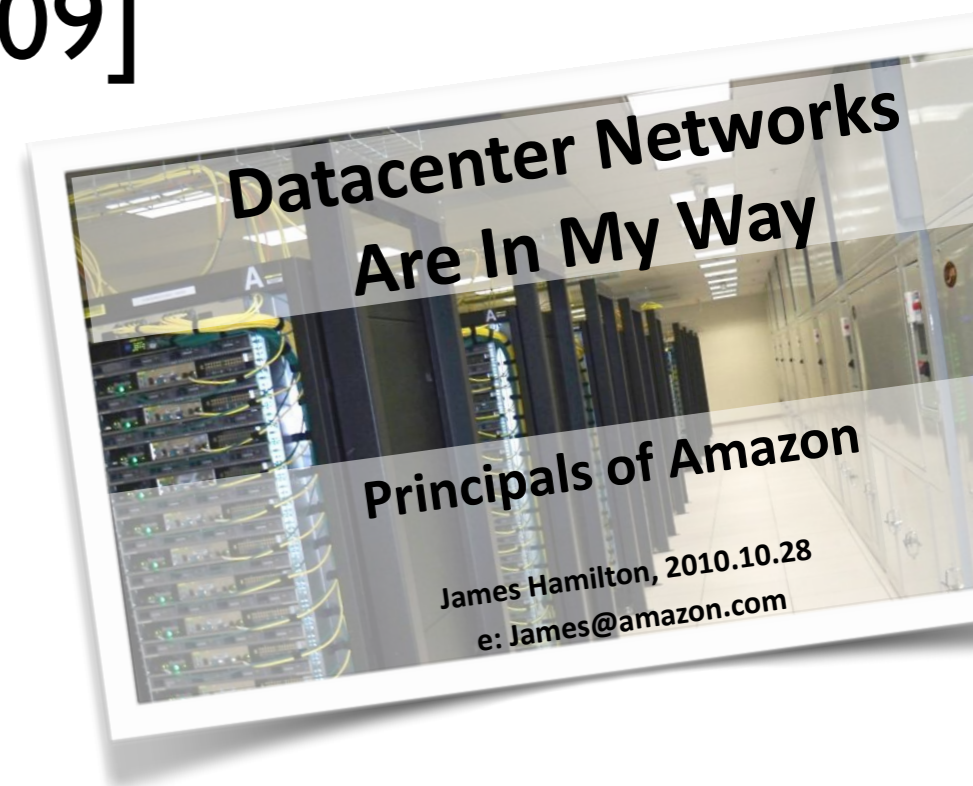

A server rack



A top-of-rack switch

A rack of servers

Lots of racks



How to network
the racks?

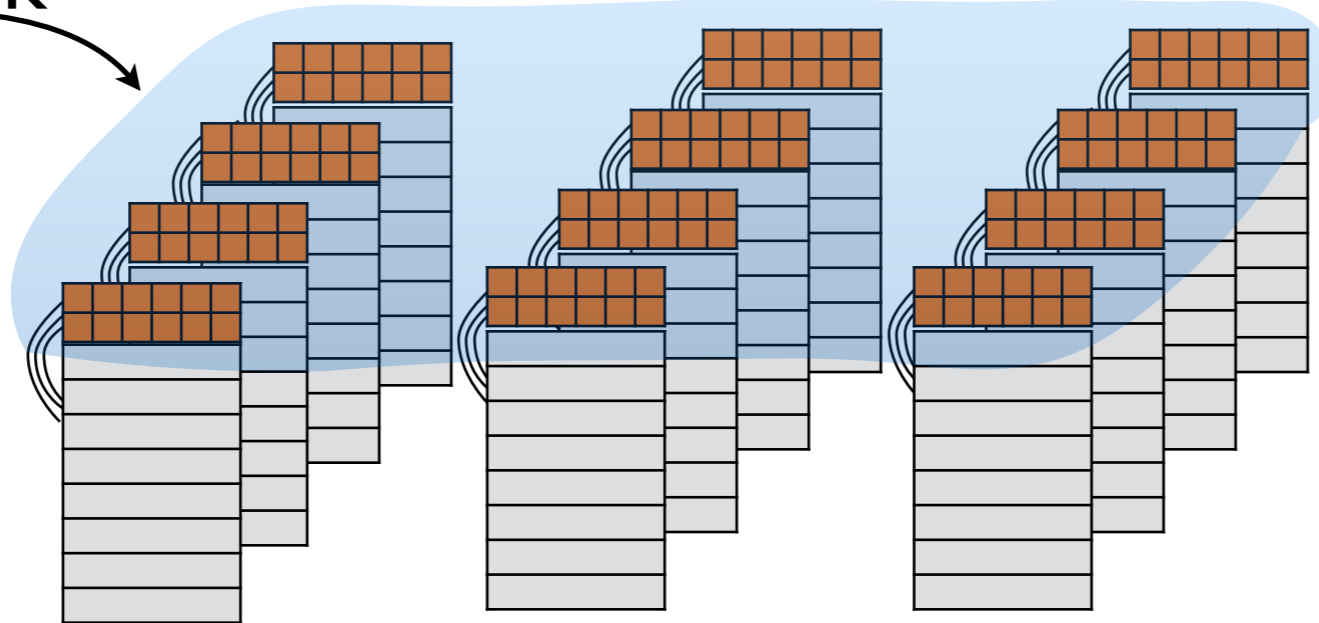

Facebook: machine-machine traffic “doubling at an interval of less than a year”

"Big switch" approach



Big crossbar

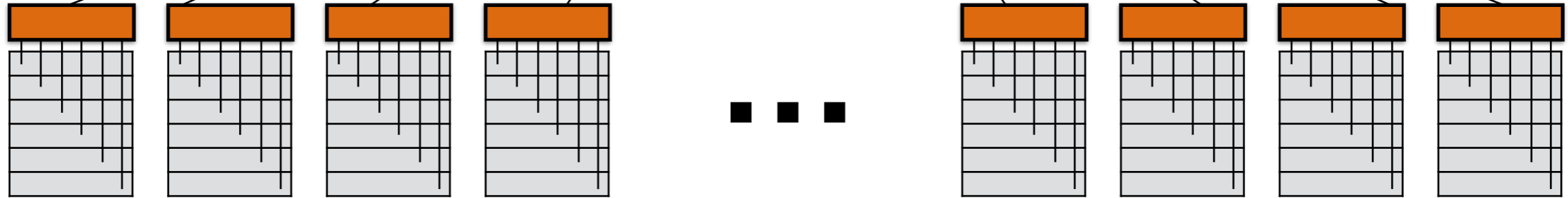
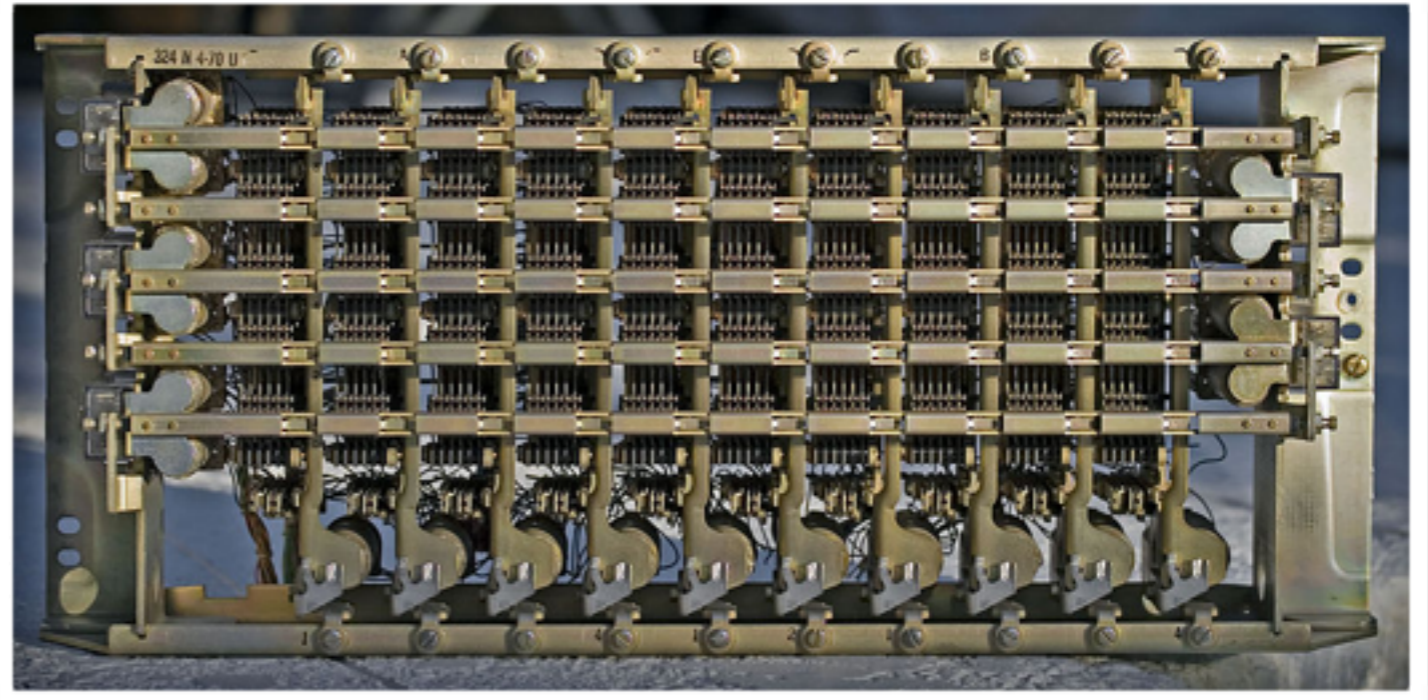

Alternative: tree network

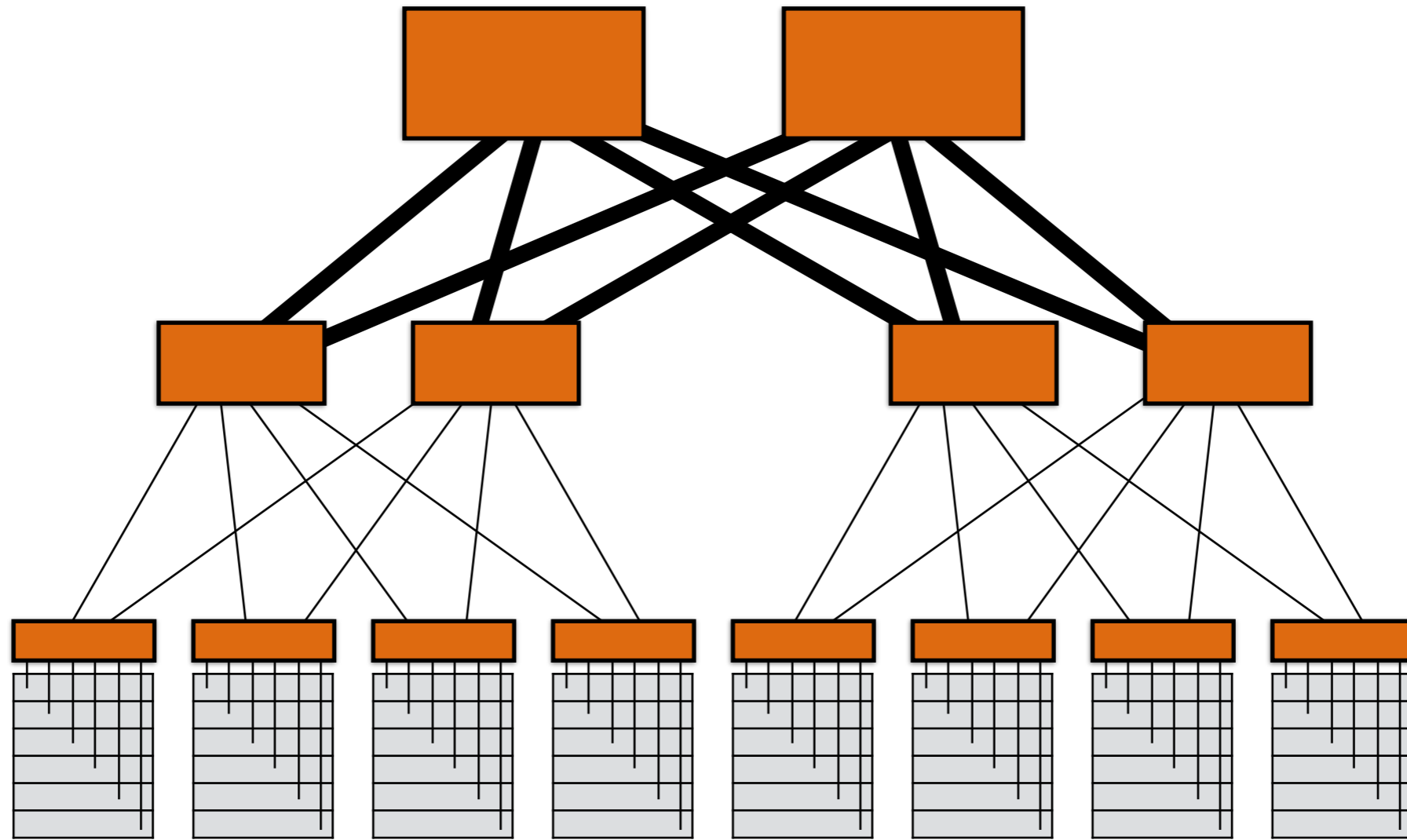

Alternative: tree network

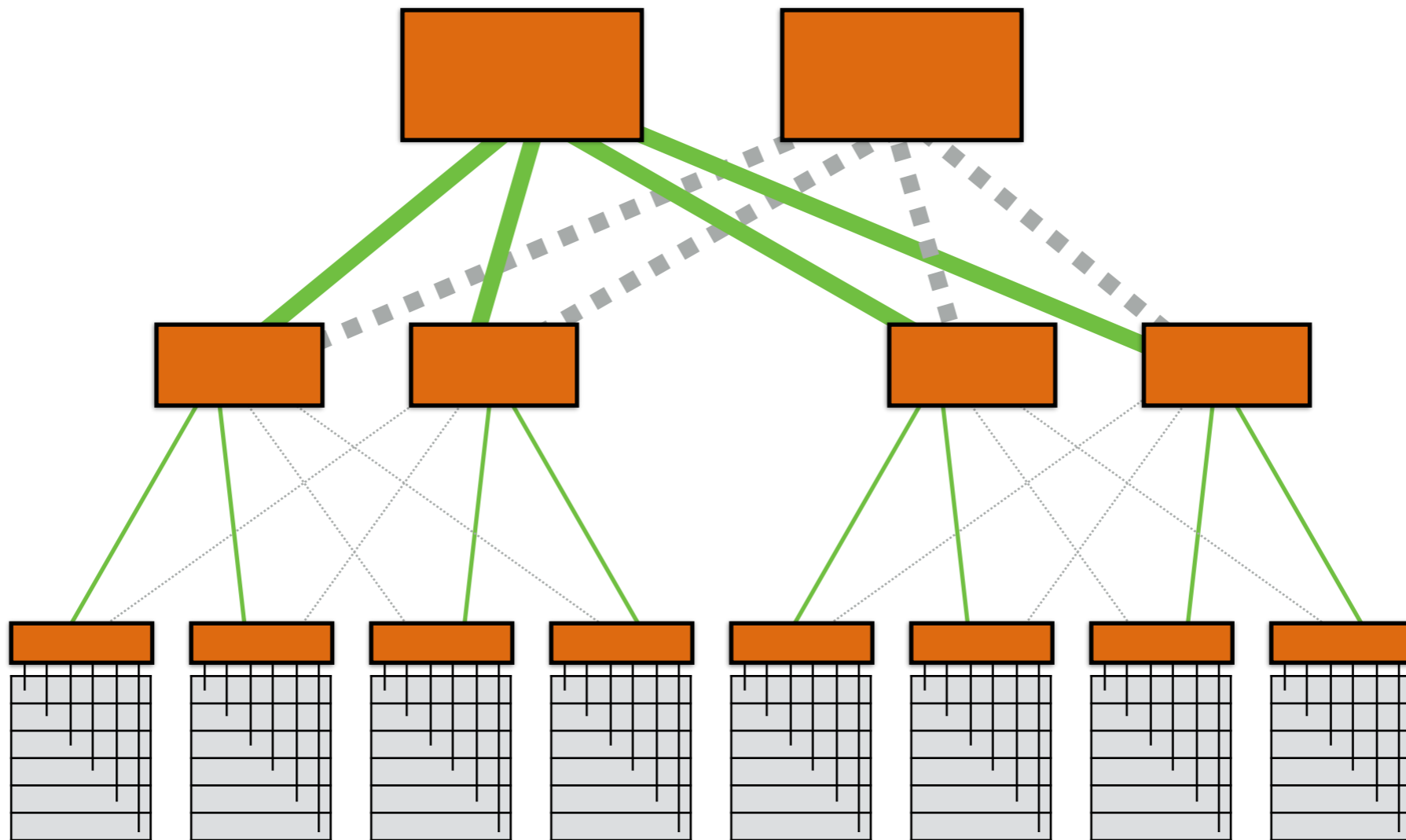

Alternative: tree network

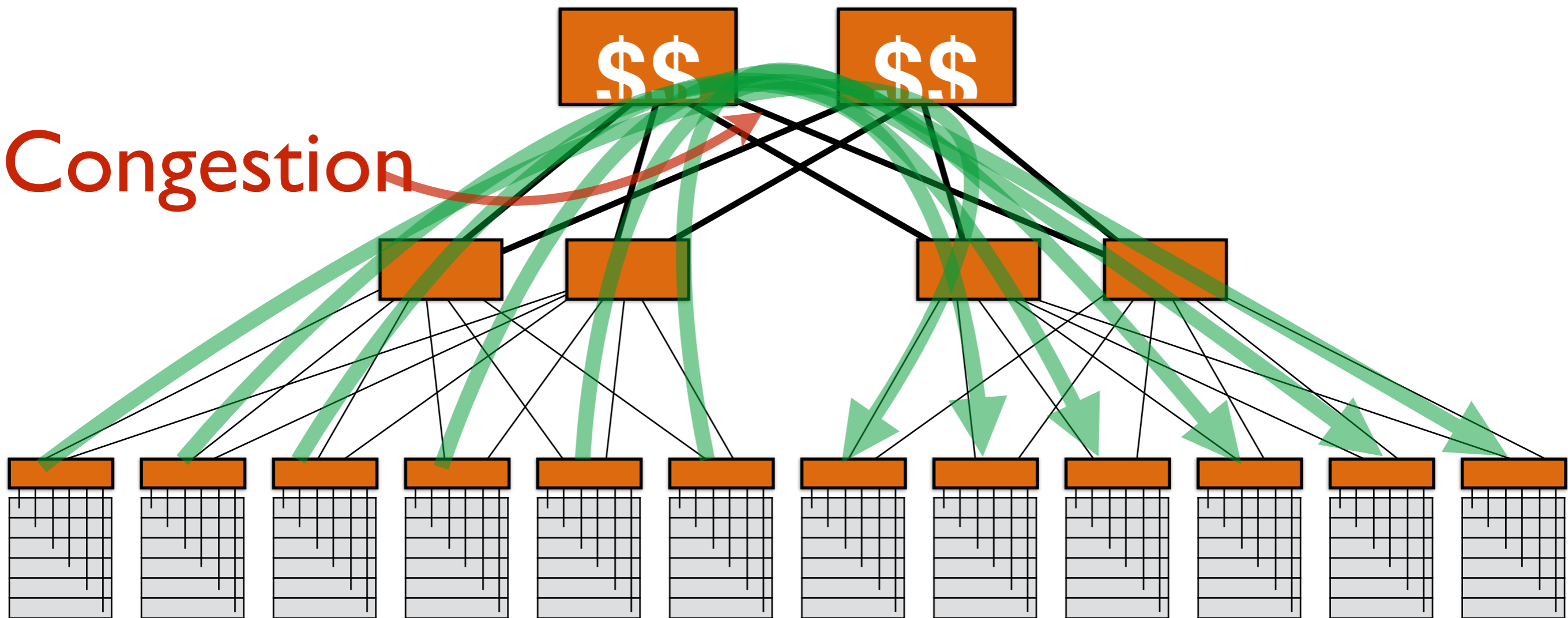

Traditional data center network

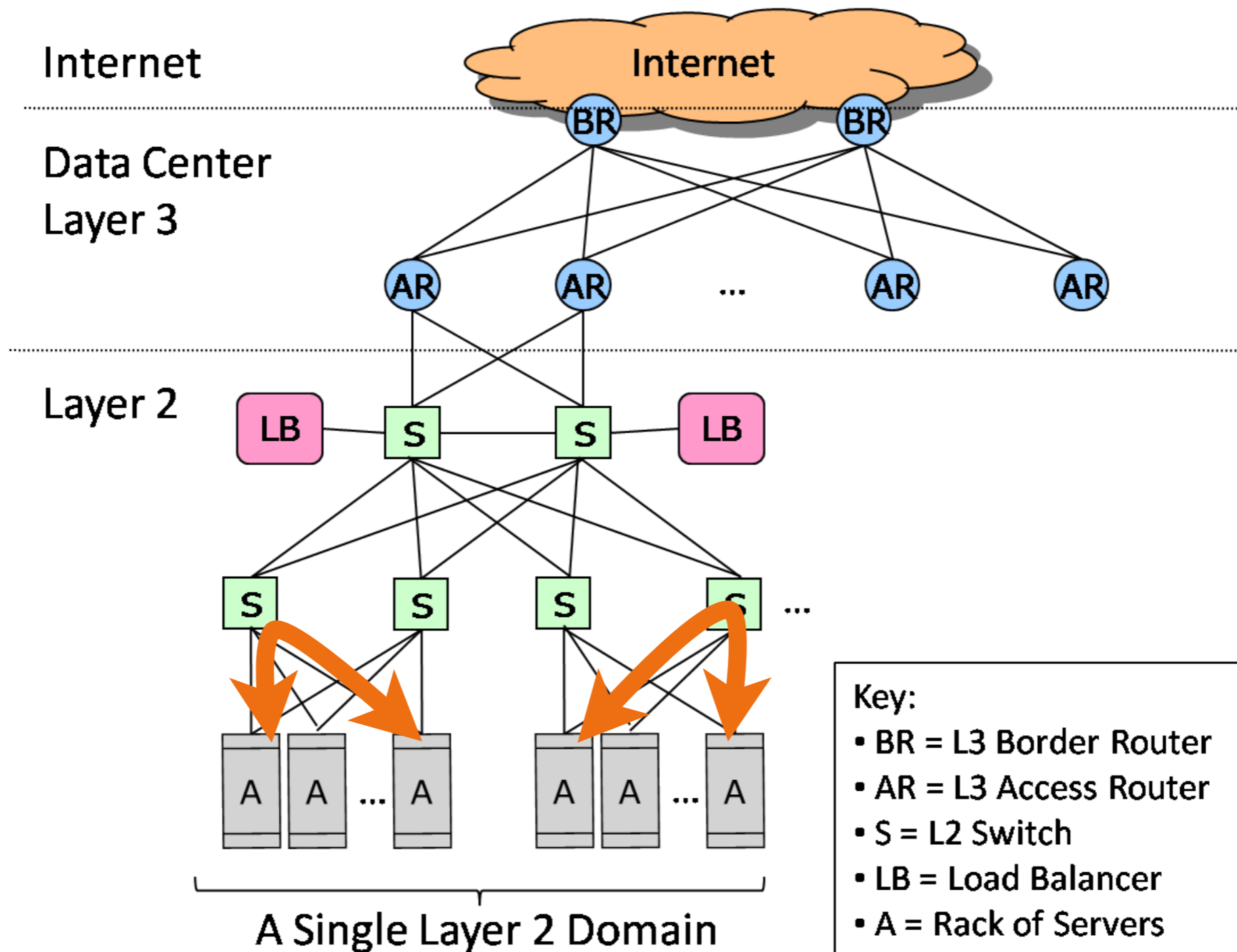

The need for performance

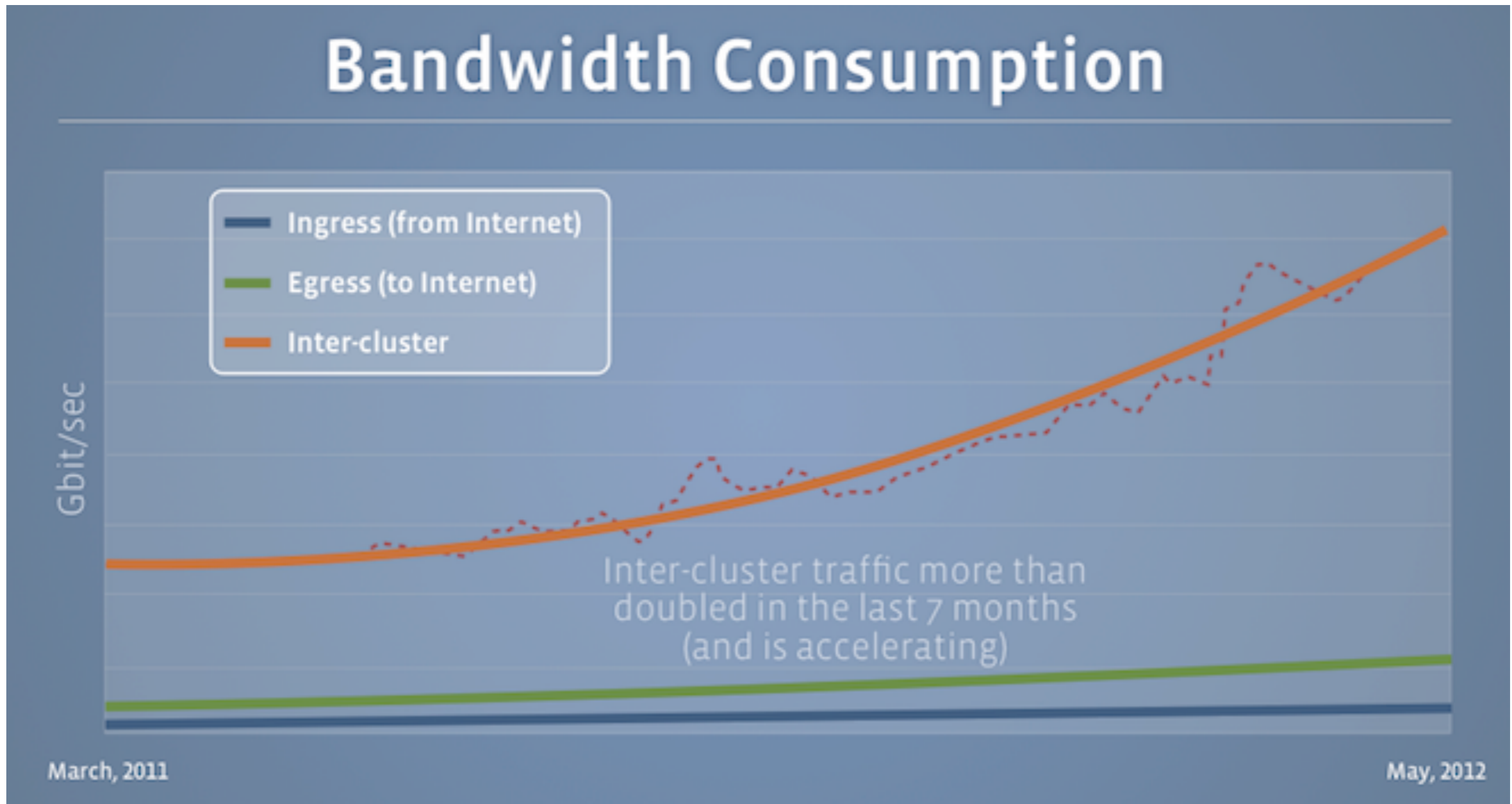

March
2011

May
2012

[Facebook, via Wired]

Modern Data Center Networks

Scalable, commodity DC net arch.



[Al-Fares, Loukissas, Vahdat, SIGCOMM 2008]

Argued for **nonblocking bandwidth**

- servers limited only by their network card's speed, regardless of communication pattern between servers
- also known as full throughput in the “hose model”

Employed large number of **commodity switches**

- rather than “big iron”

Arranged in **Clos topology**

- specifically, a “fat tree”

Fat tree network

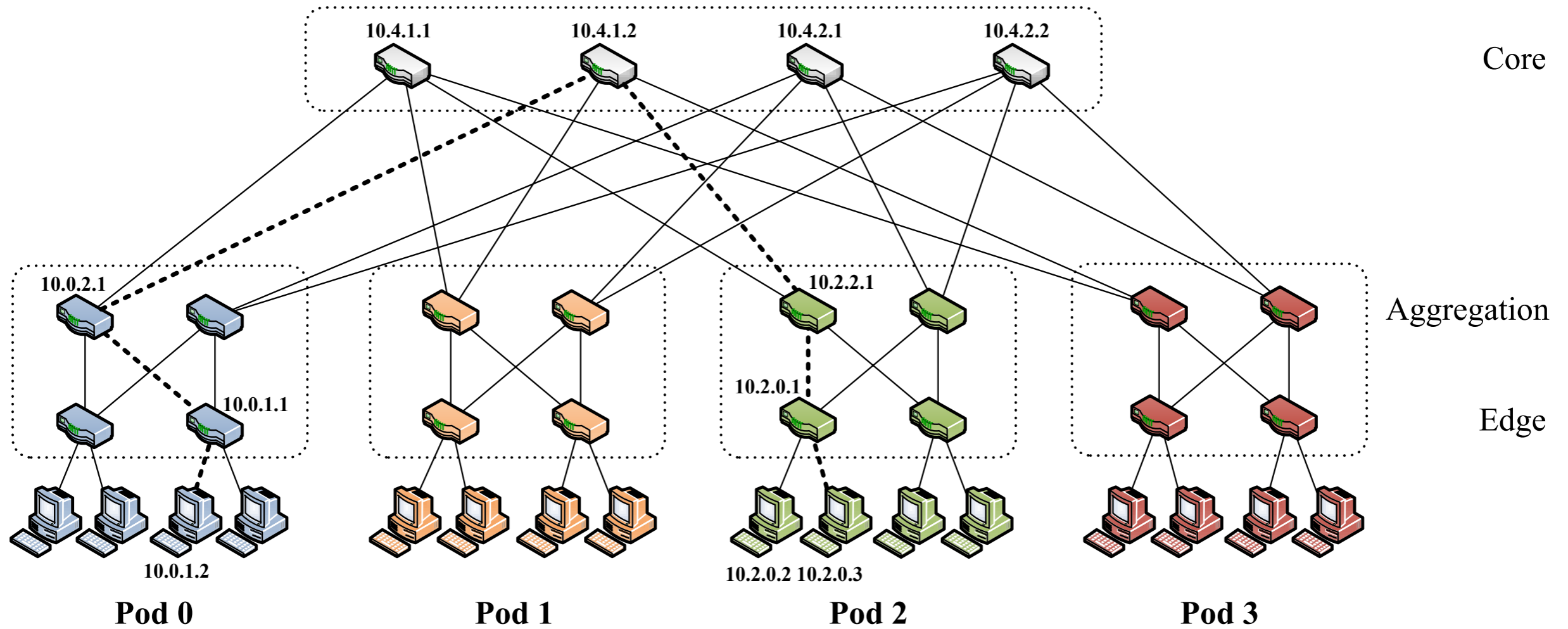

[Al-Fares,
Loukissas, Vahdat,
SIGCOMM '08]

Fat tree network

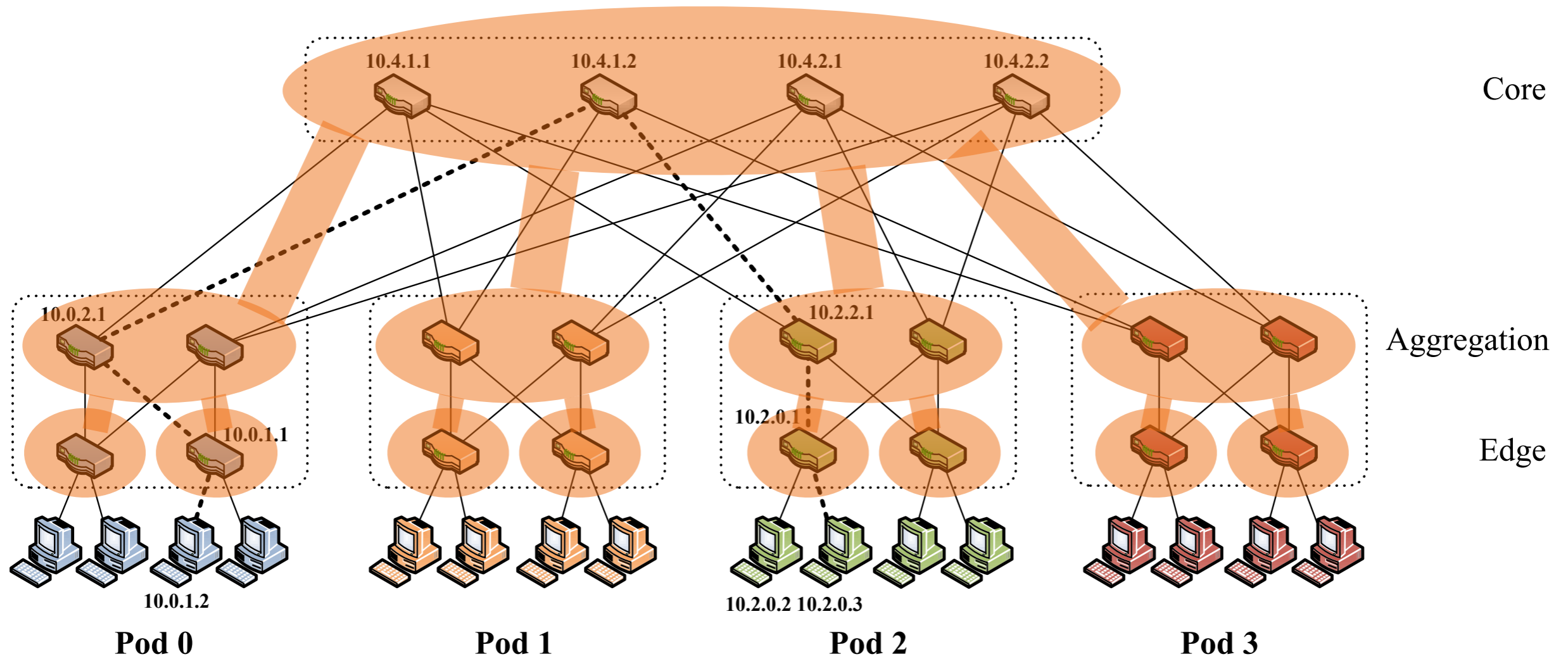

[Al-Fares,
Loukissas, Vahdat,
SIGCOMM '08]

Fat tree network

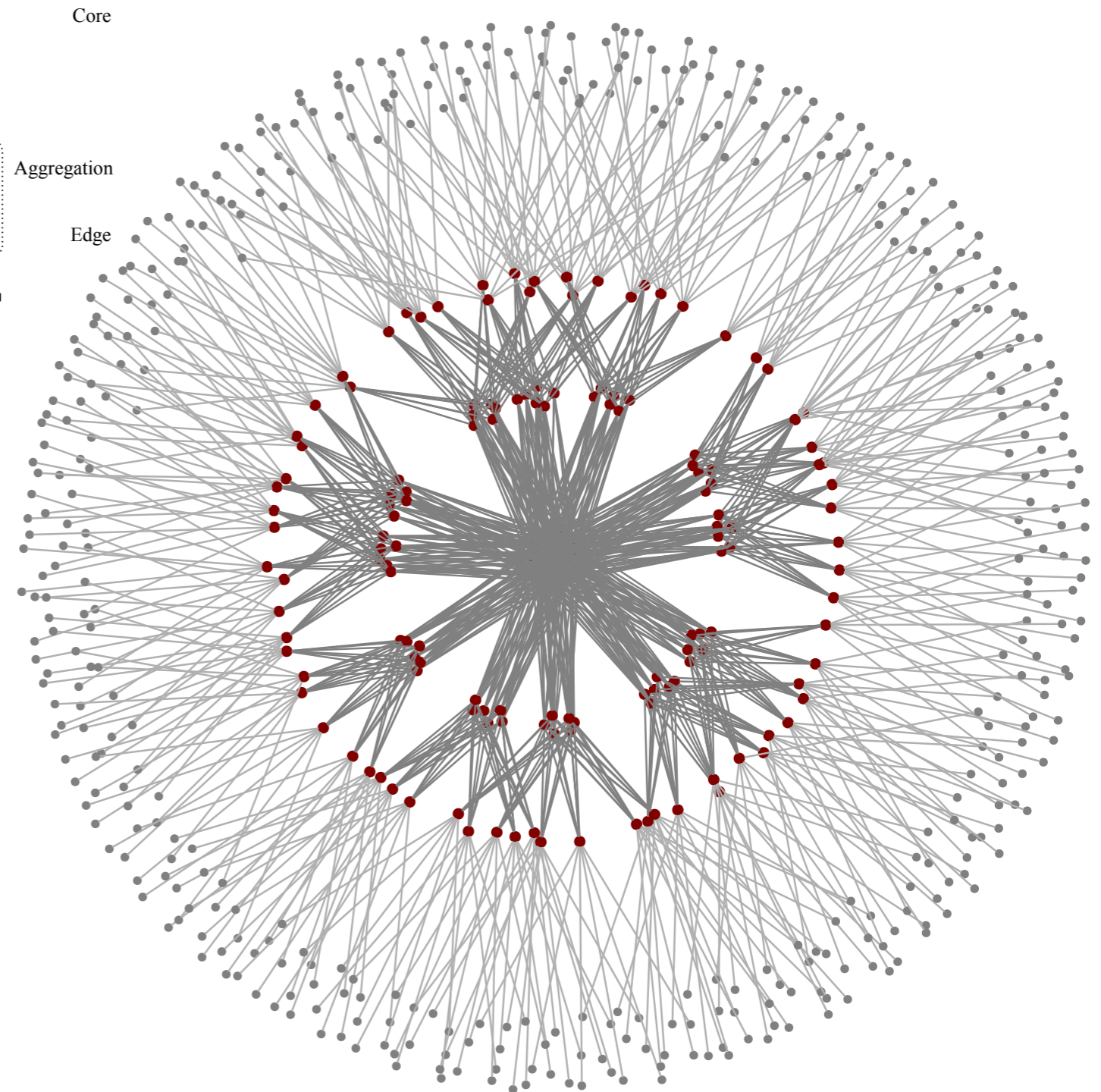
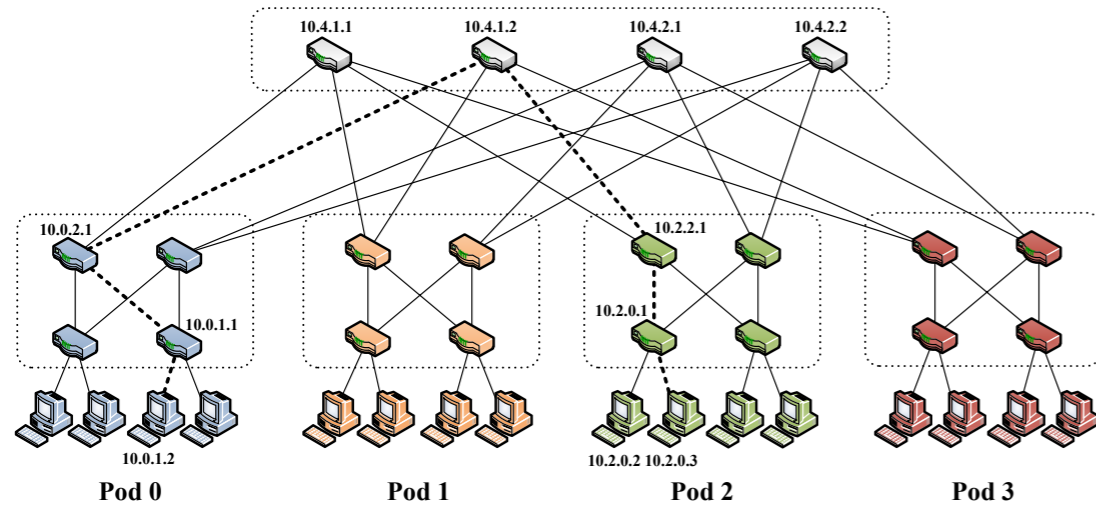

Fat tree network

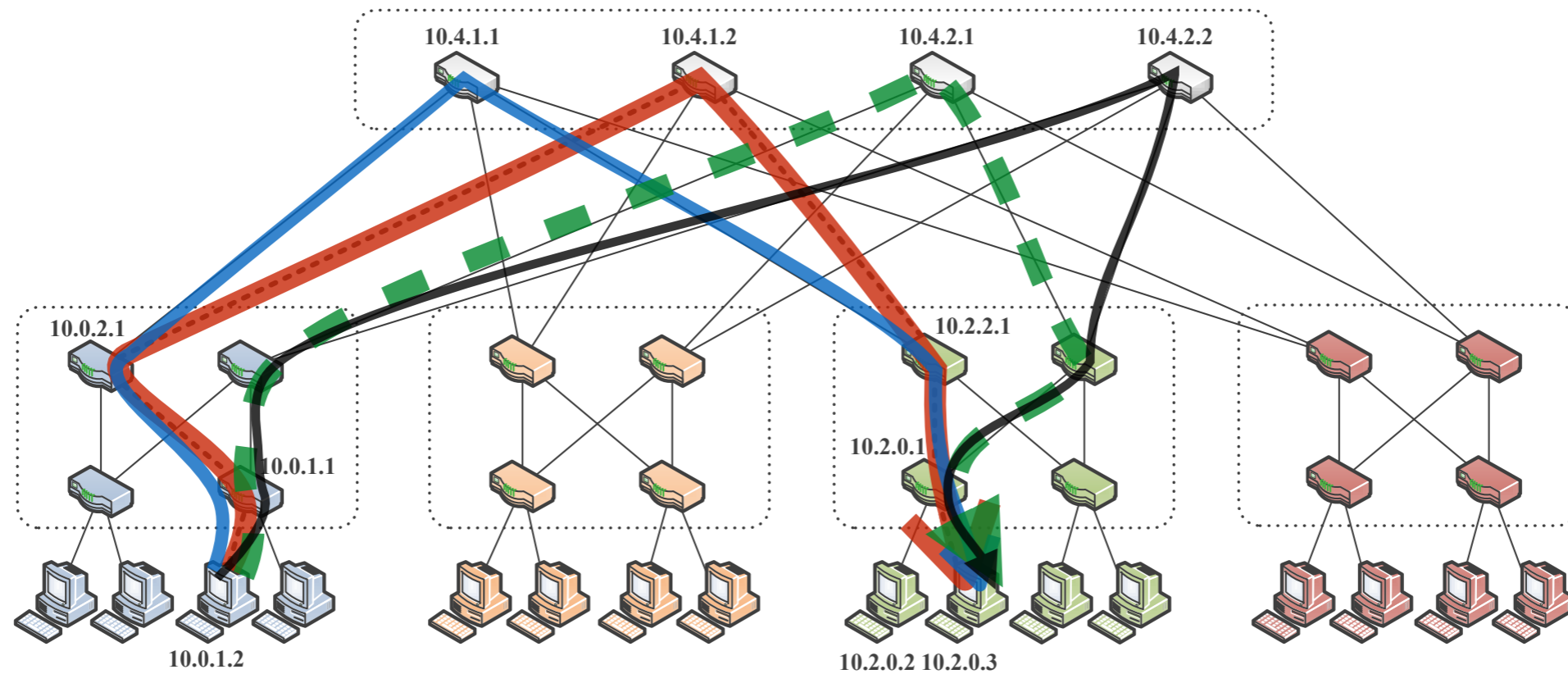

ACM SIGCOMM, 2008

A Scalable, Commodity Data Center Network Architecture

Mohammad Al-Fares

Alexander Loukissas

Amin Vahdat

Fat tree network

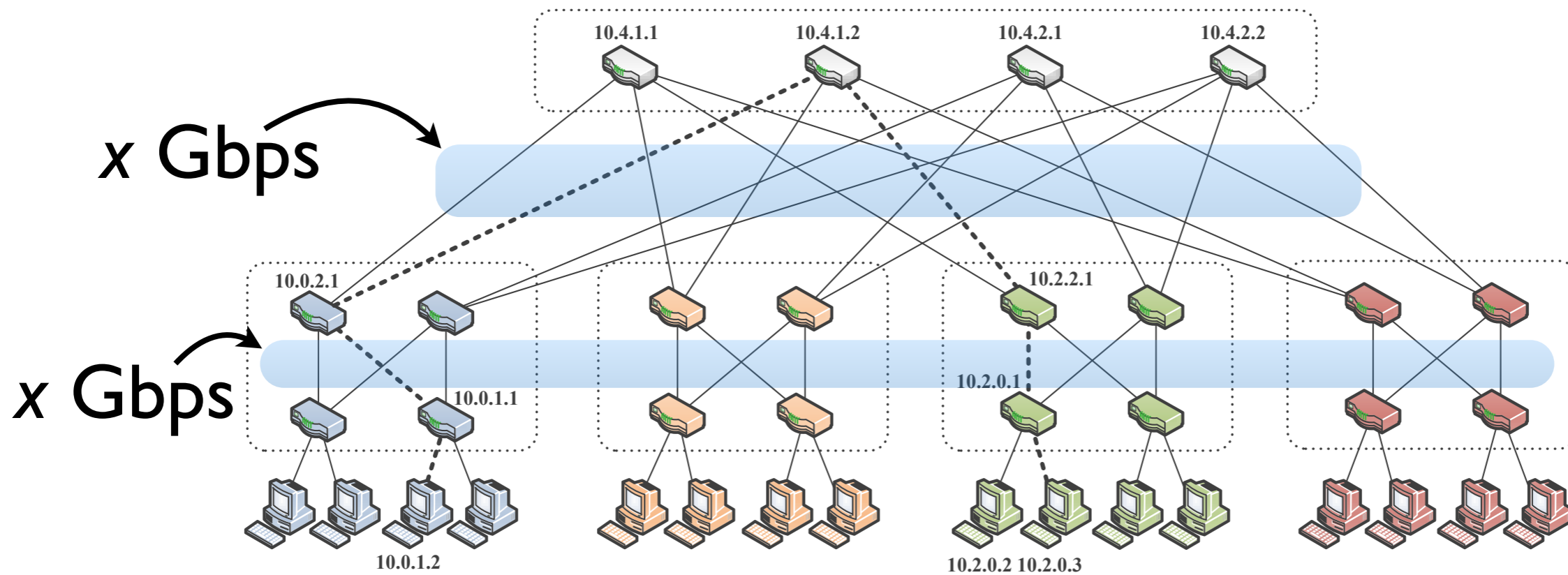

ACM SIGCOMM, 2008

A Scalable, Commodity Data Center Network Architecture

Mohammad Al-Fares

Alexander Loukissas

Amin Vahdat

Oversubscribed fat tree

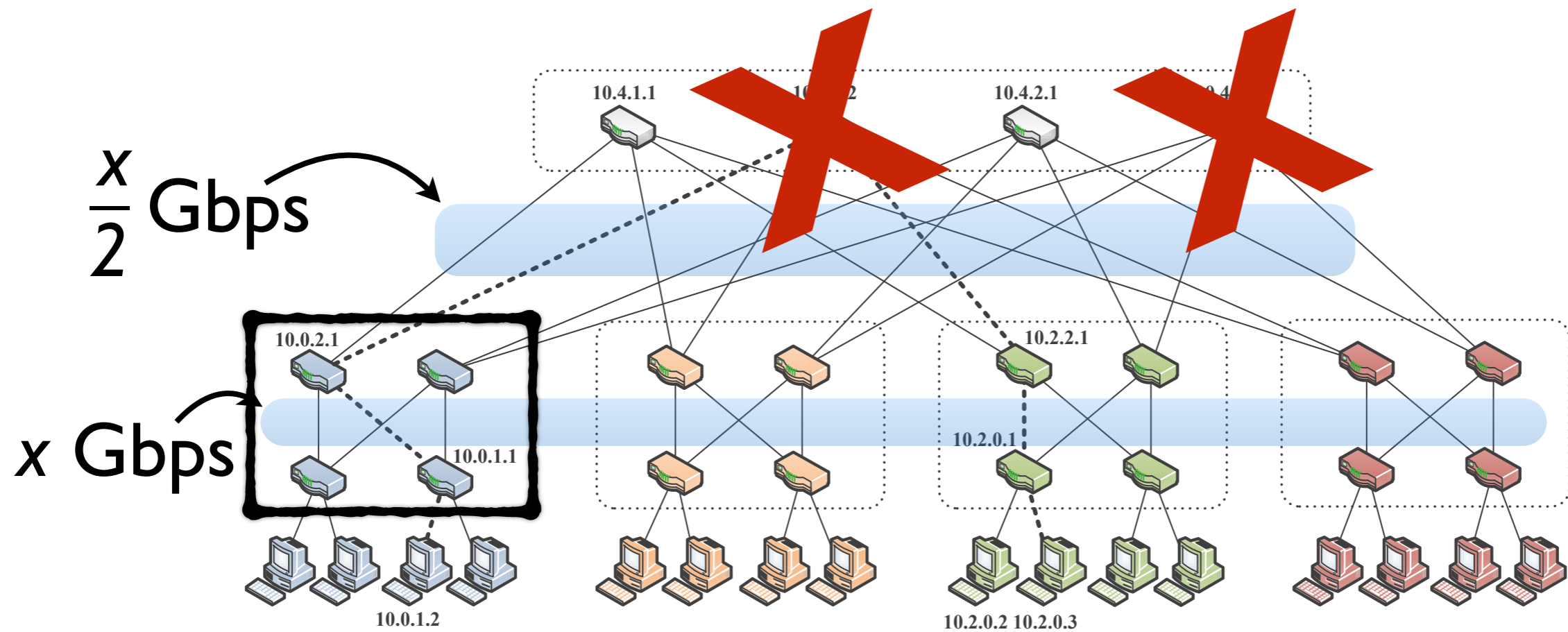

ACM SIGCOMM, 2008

A Scalable, Commodity Data Center Network Architecture

Mohammad Al-Fares

Alexander Loukissas

Amin Vahdat

Jupiter Rising: A Decade of Clos Topologies and Centralized Control in Google's Datacenter Network

Arjun Singh, Joon Ong, Amit Agarwal, Glen Anderson, Ashby Armistead, Roy Bannon, Seb Boving, Gaurav Desai, Bob Felderman, Paulie Germano, Anand Kanagala, Jeff Provost, Jason Simmons, Eiichi Tanda, Jim Wanderer, Urs Hölzle, Stephen Stuart, and Amin Vahdat
Google, Inc.

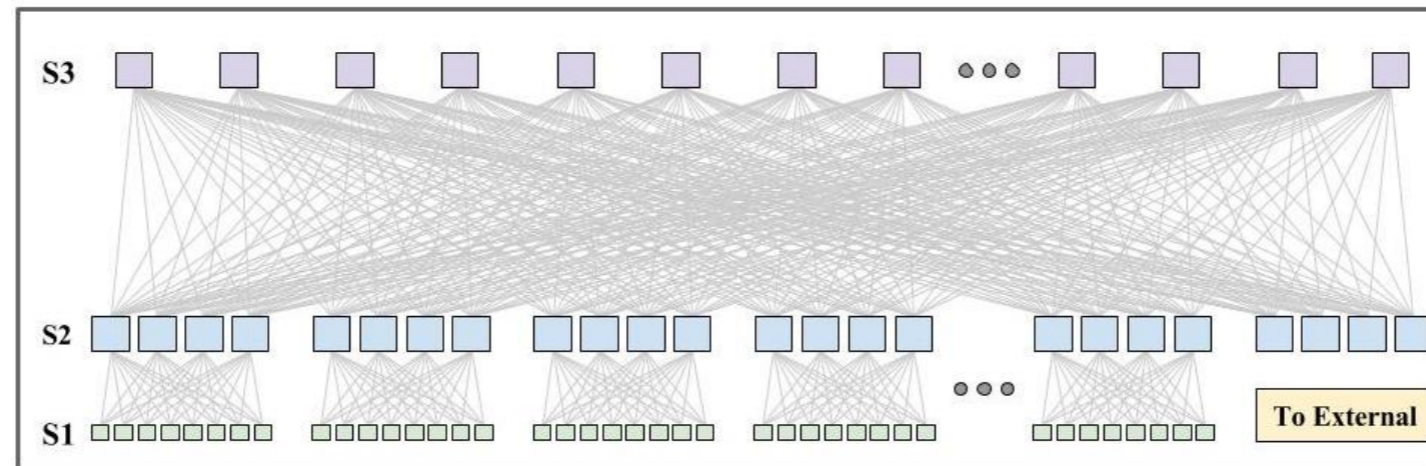
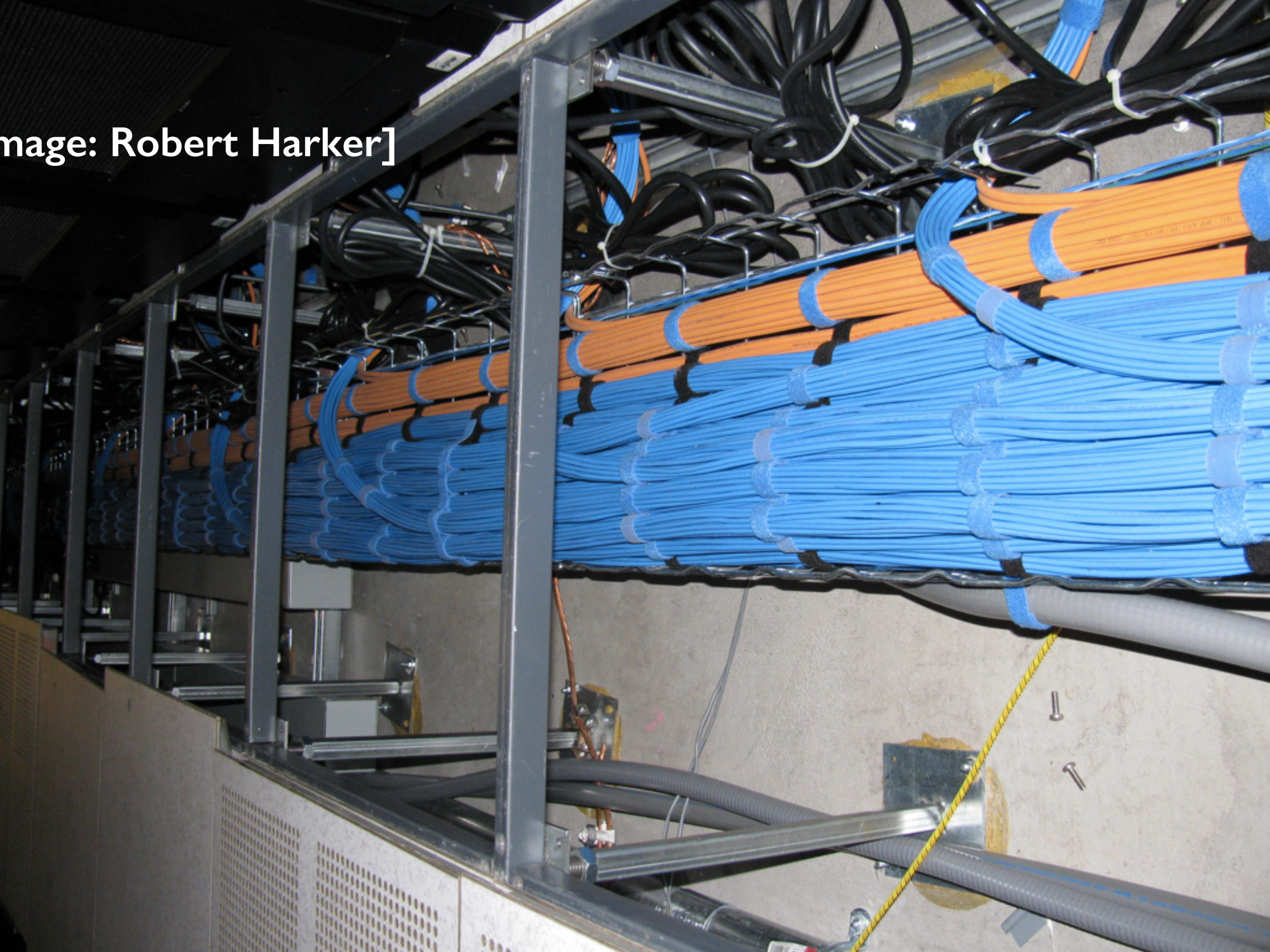
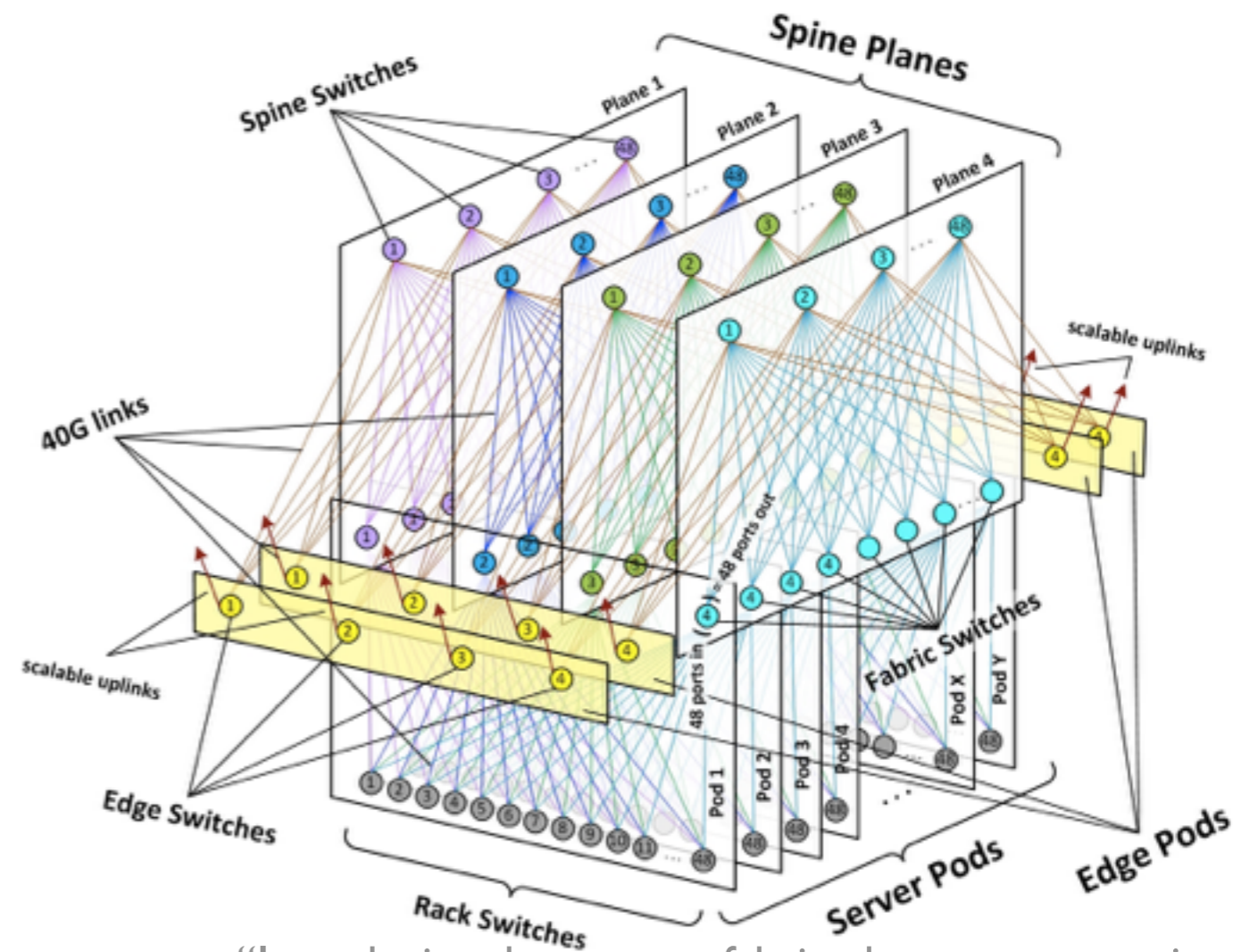
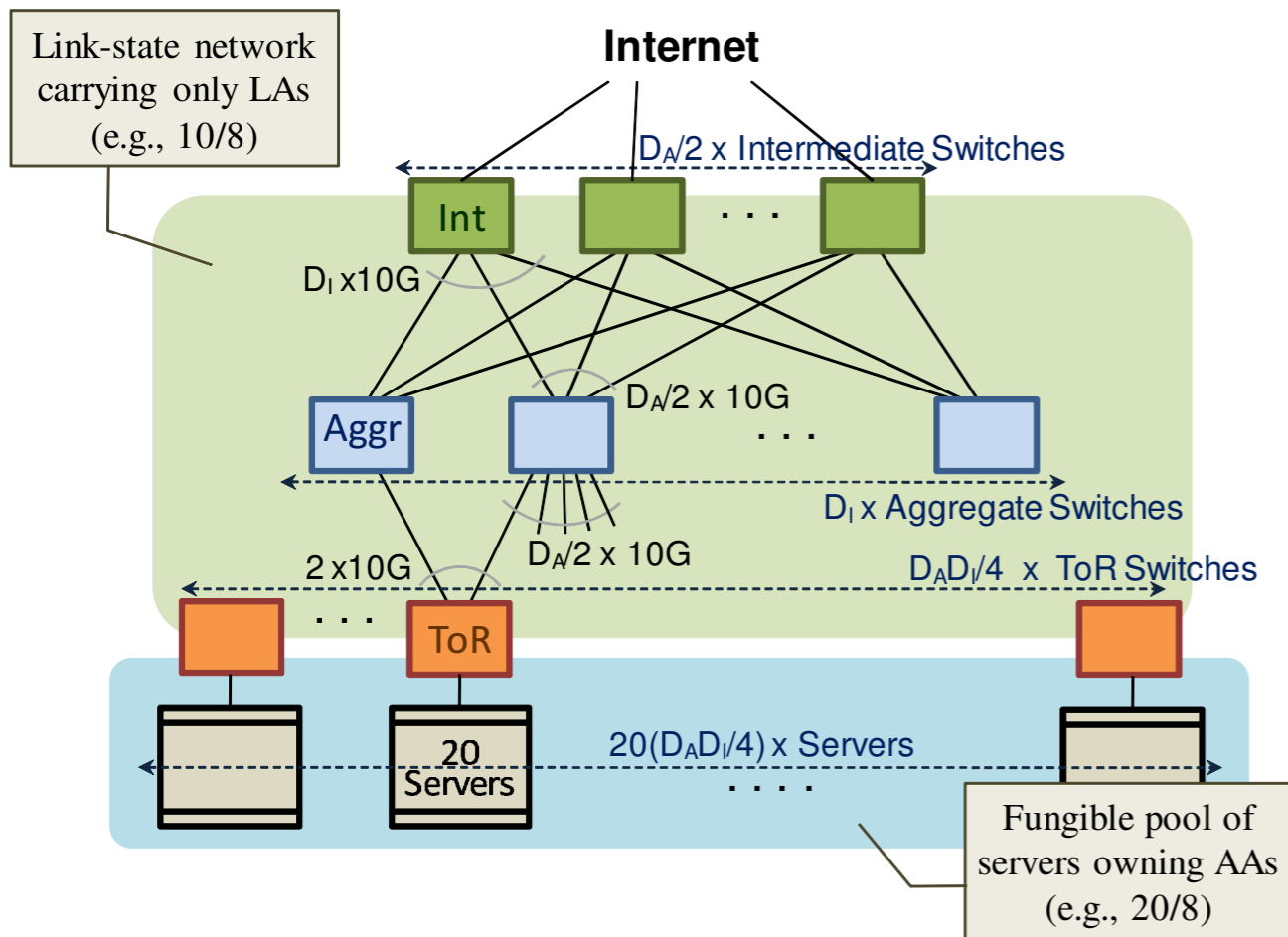

Image: Robert Harker]



Variants of this design are common



VL2 @ **Microsoft**, ACM SIGCOMM'09
Greenburg, Hamilton, Jain, Kandula, Kim, Lahiri, Maltz, Patel,
Sengupta

“Introducing data center fabric, the next-generation
data center network”, Alexey Andreyev, 2015
Facebook

Many other proposed topologies

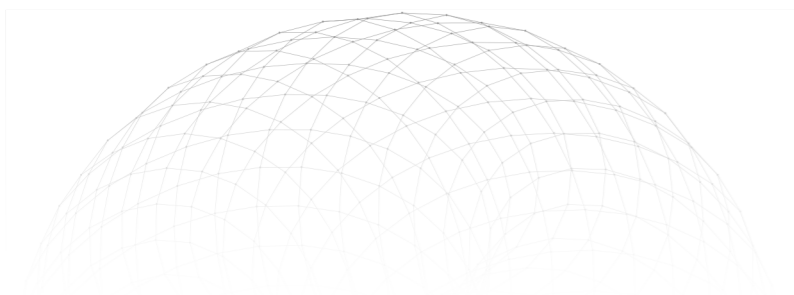
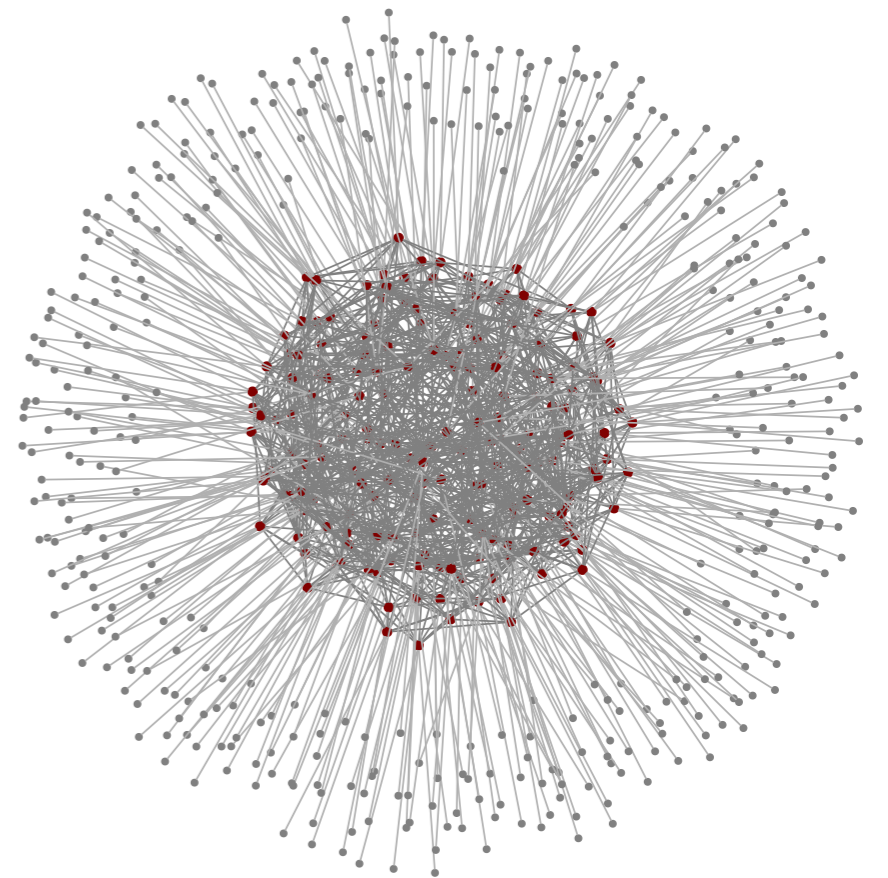
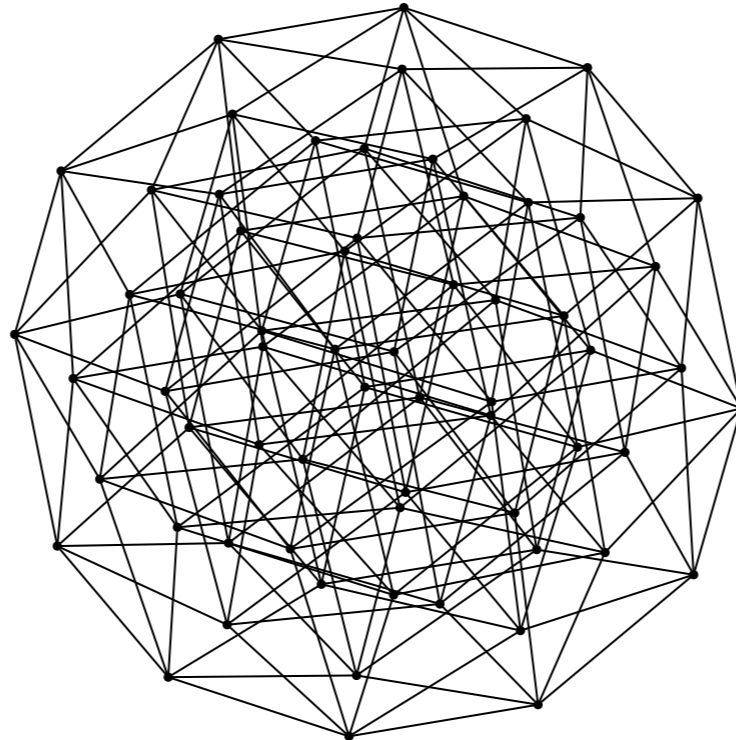
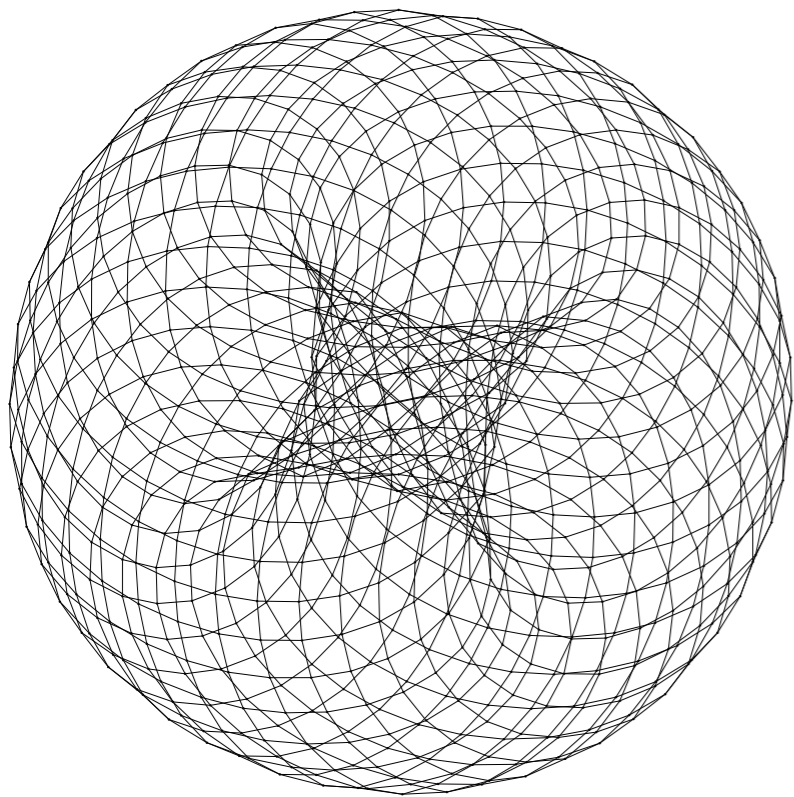

Routing in Data Center Networks

Traditional data center network

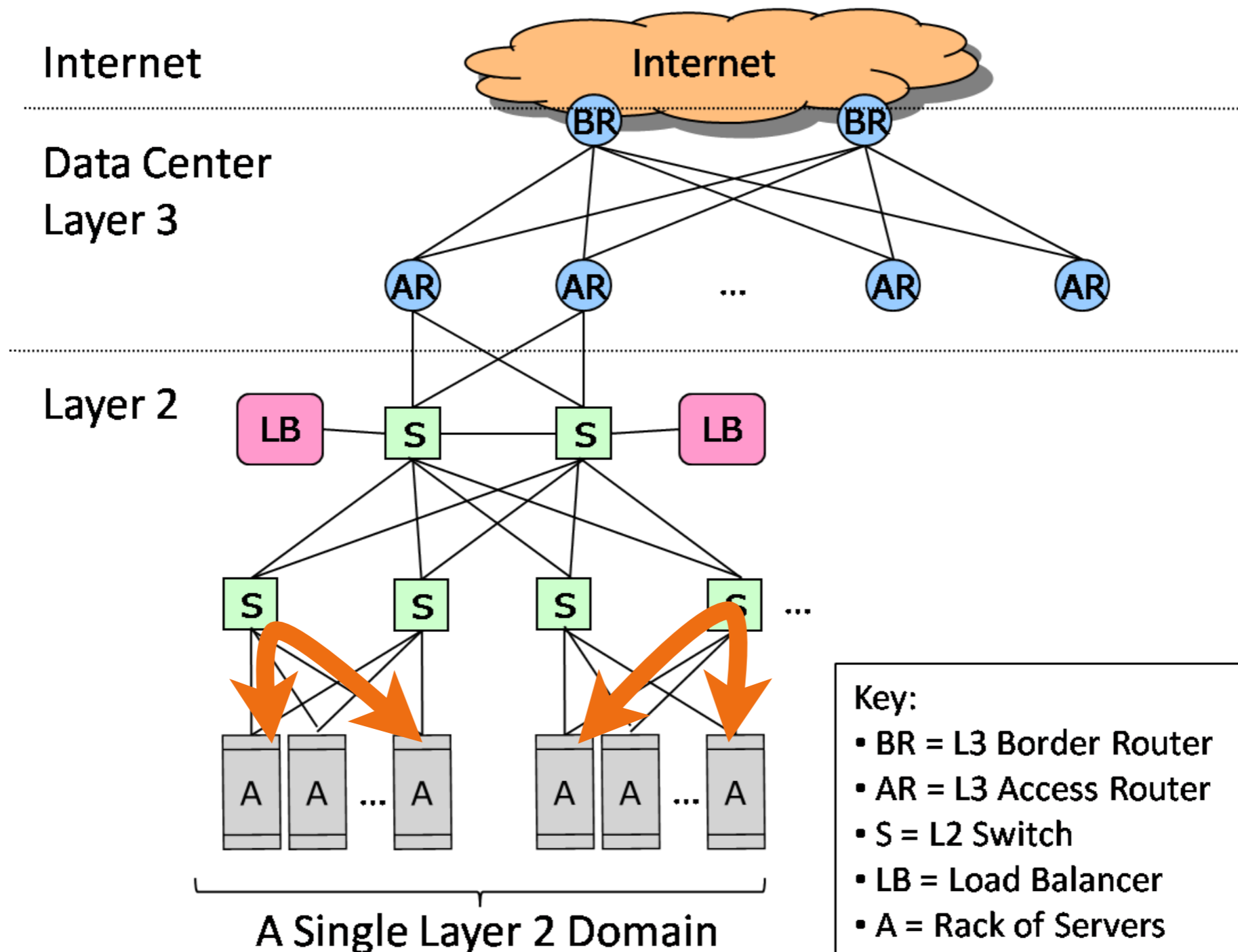

Spanning tree

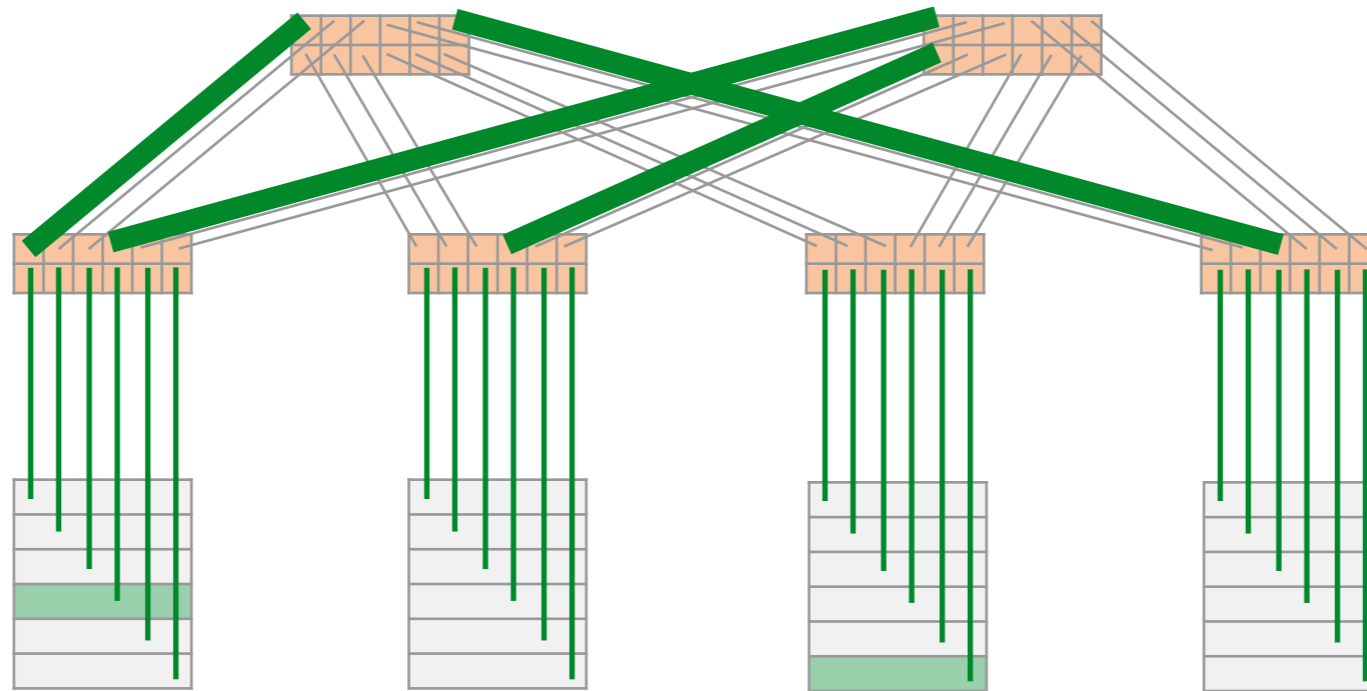

Disable all other links!

STP works for tree-like networks

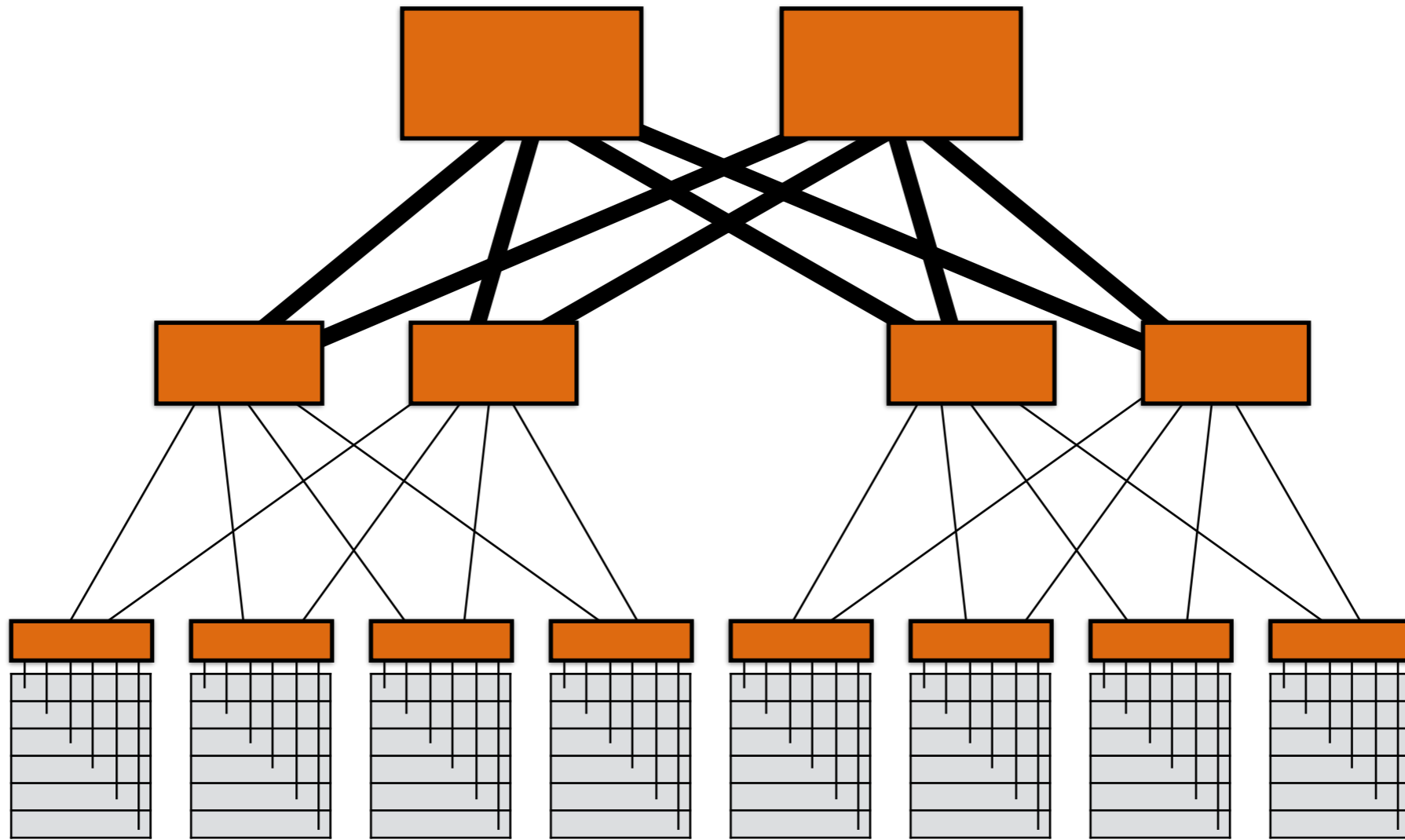

STP works for tree-like networks

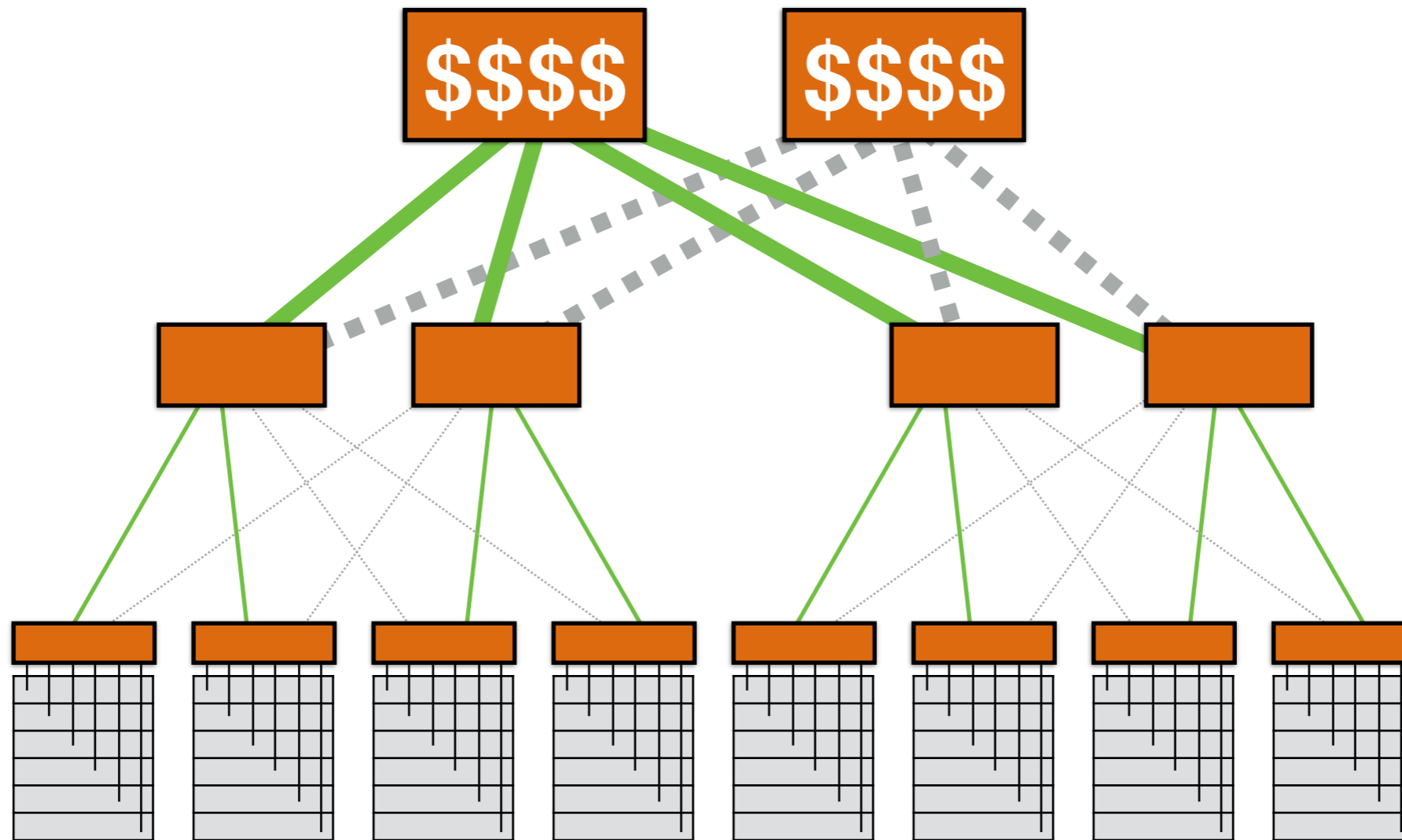

STP works for tree-like networks

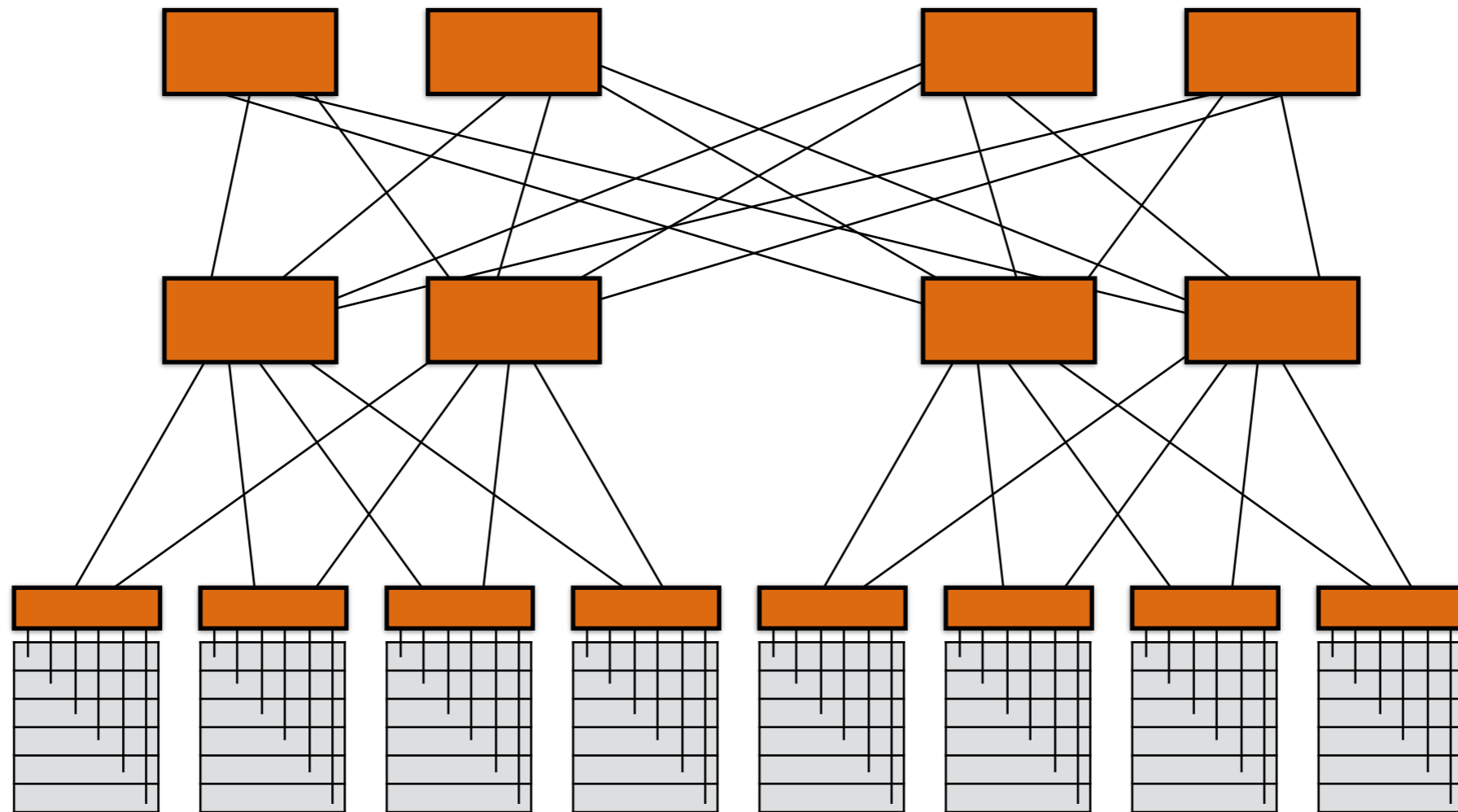

BGP: Border Gateway Protocol

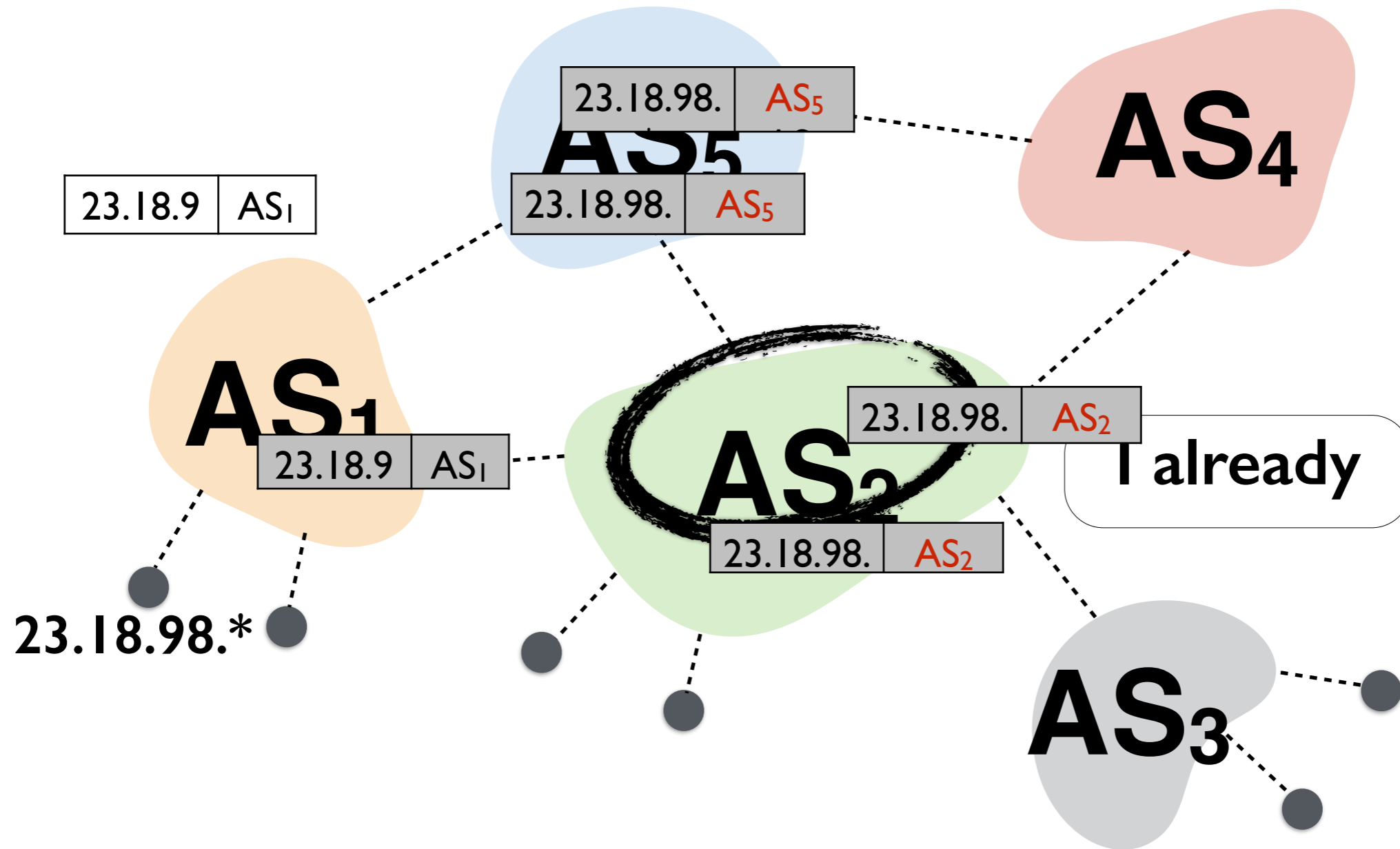

BGP in the data center

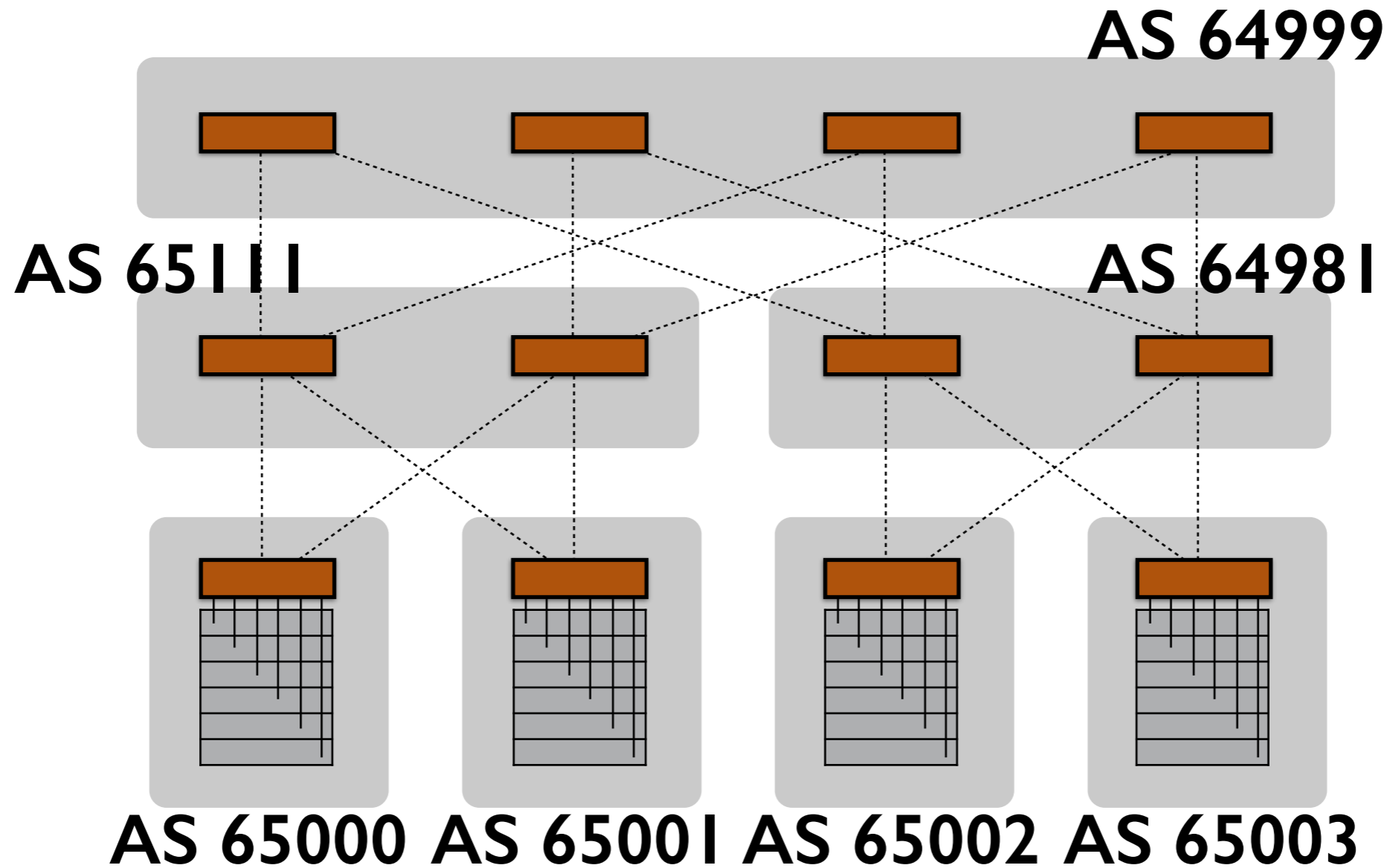

Routing

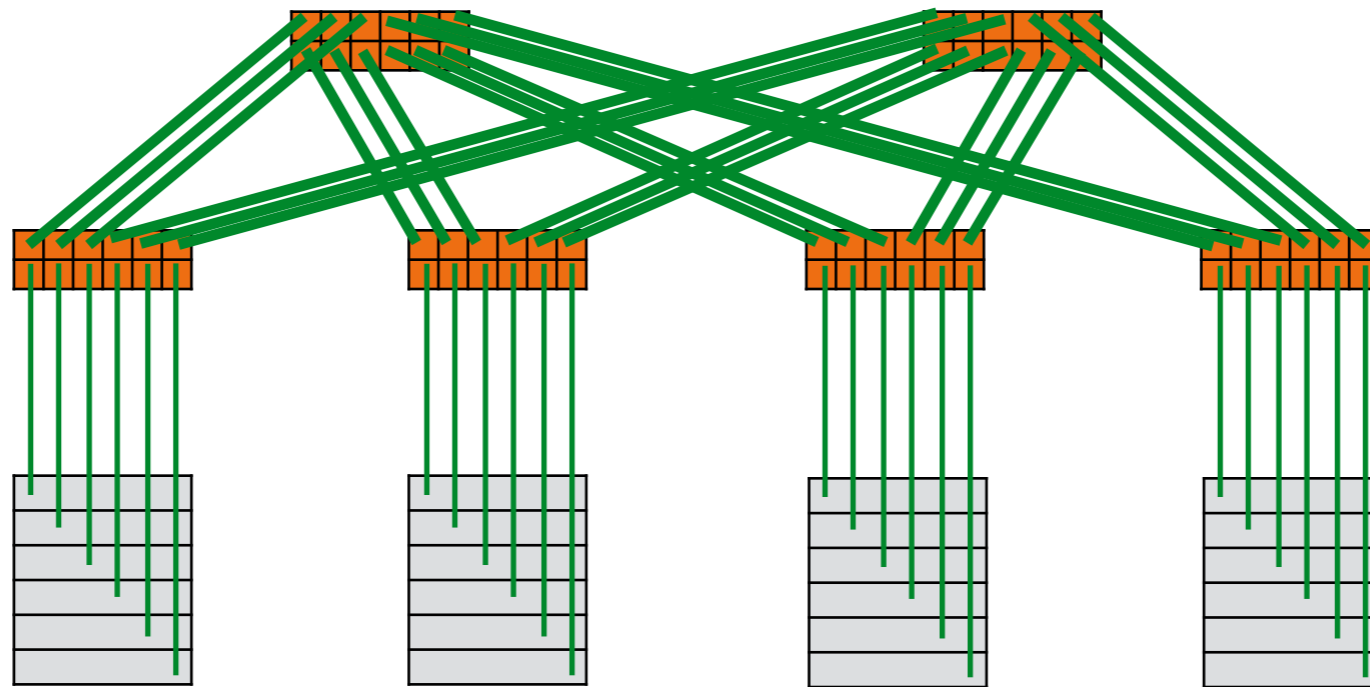

Multipath routing

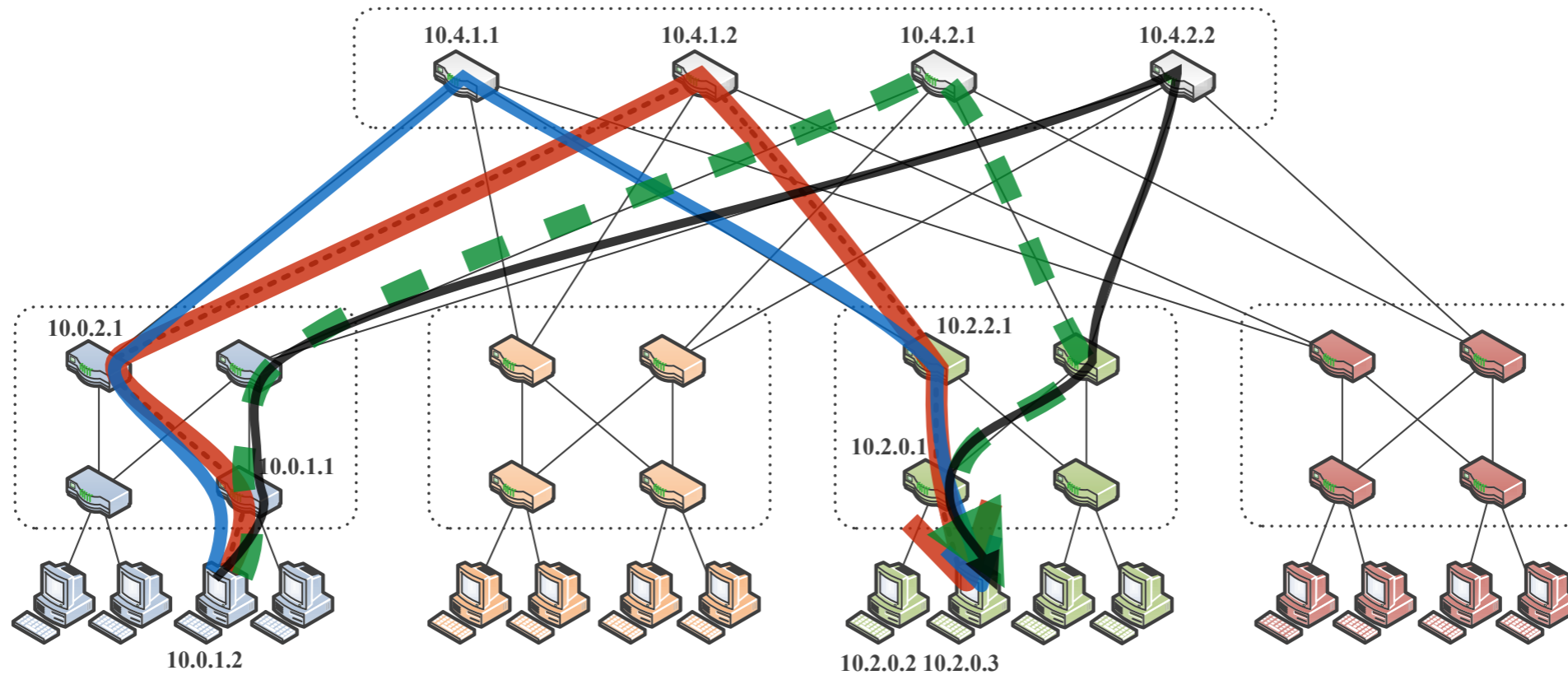

A Scalable, Commodity Data Center Network Architecture

Mohammad Al-Fares
malfares@cs.ucsd.edu

Alexander Loukissas
aloukiss@cs.ucsd.edu

Amin Vahdat
vahdat@cs.ucsd.edu

Equal cost multi-path (ECMP)

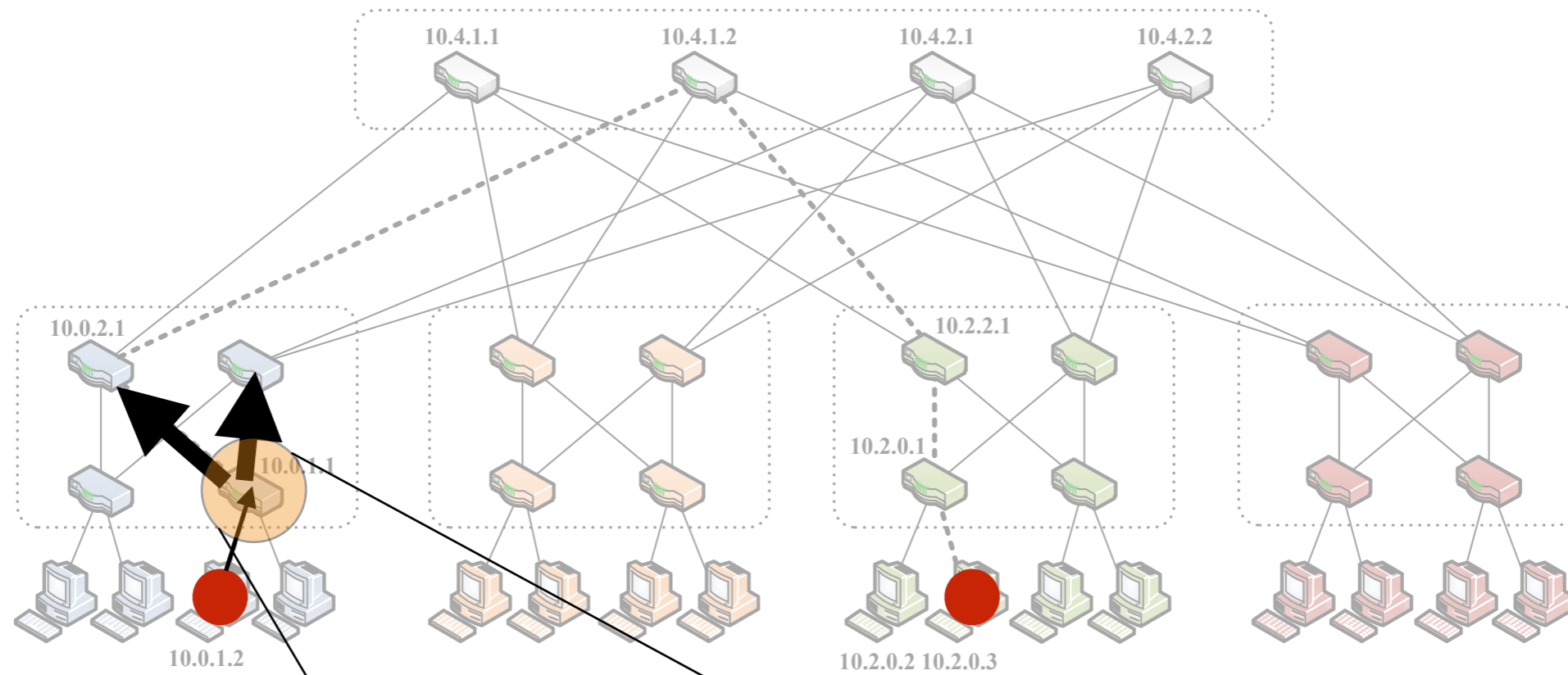

10.2.0.3	port 1
10.2.0.3	port 2

**Choose uniformly
at random!**

Equal cost multi-path (ECMP)

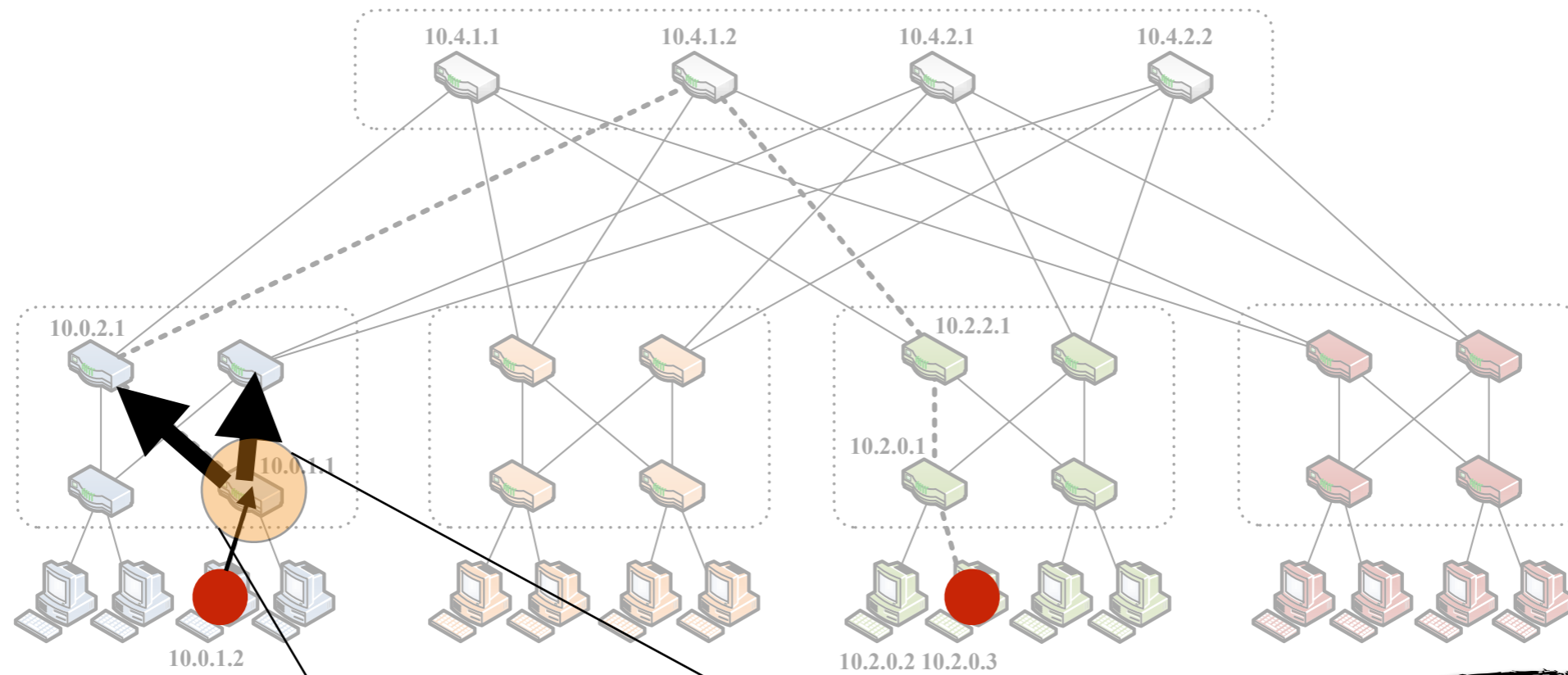

10.2.0.3	port 1
10.2.0.3	port 2

**Choose uniformly
at random!**

Equal cost multi-path (ECMP)

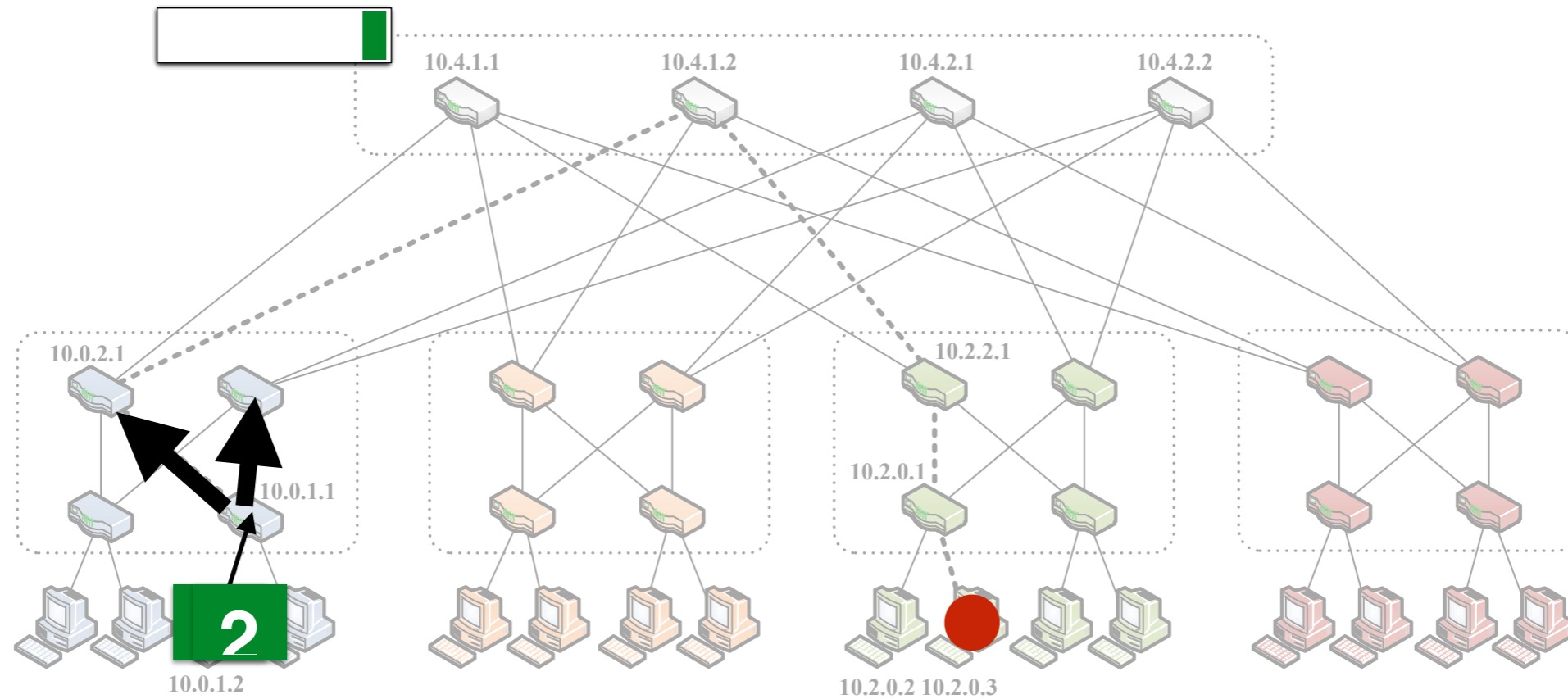

Output port = **hash** (packet header)

Equal cost multi-path (ECMP)

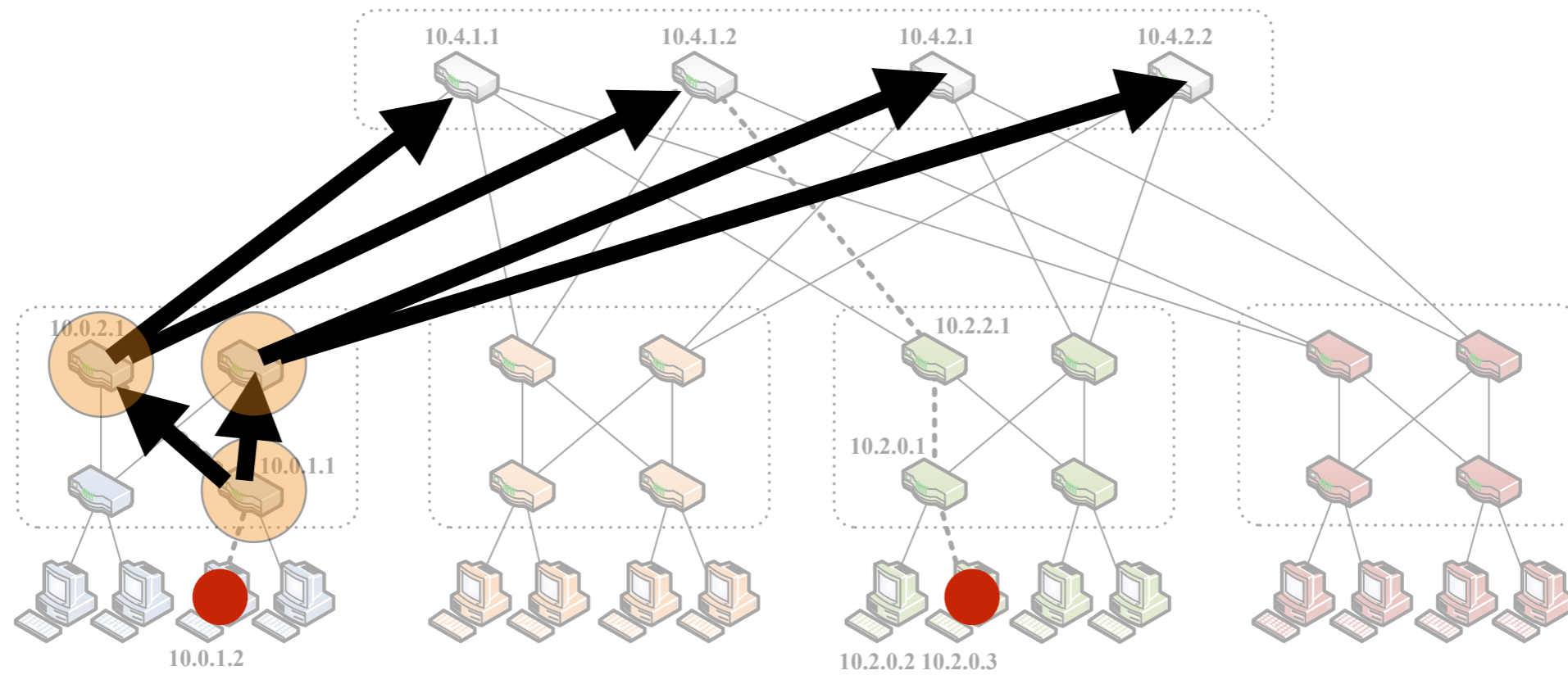

Equal cost multi-path (ECMP)

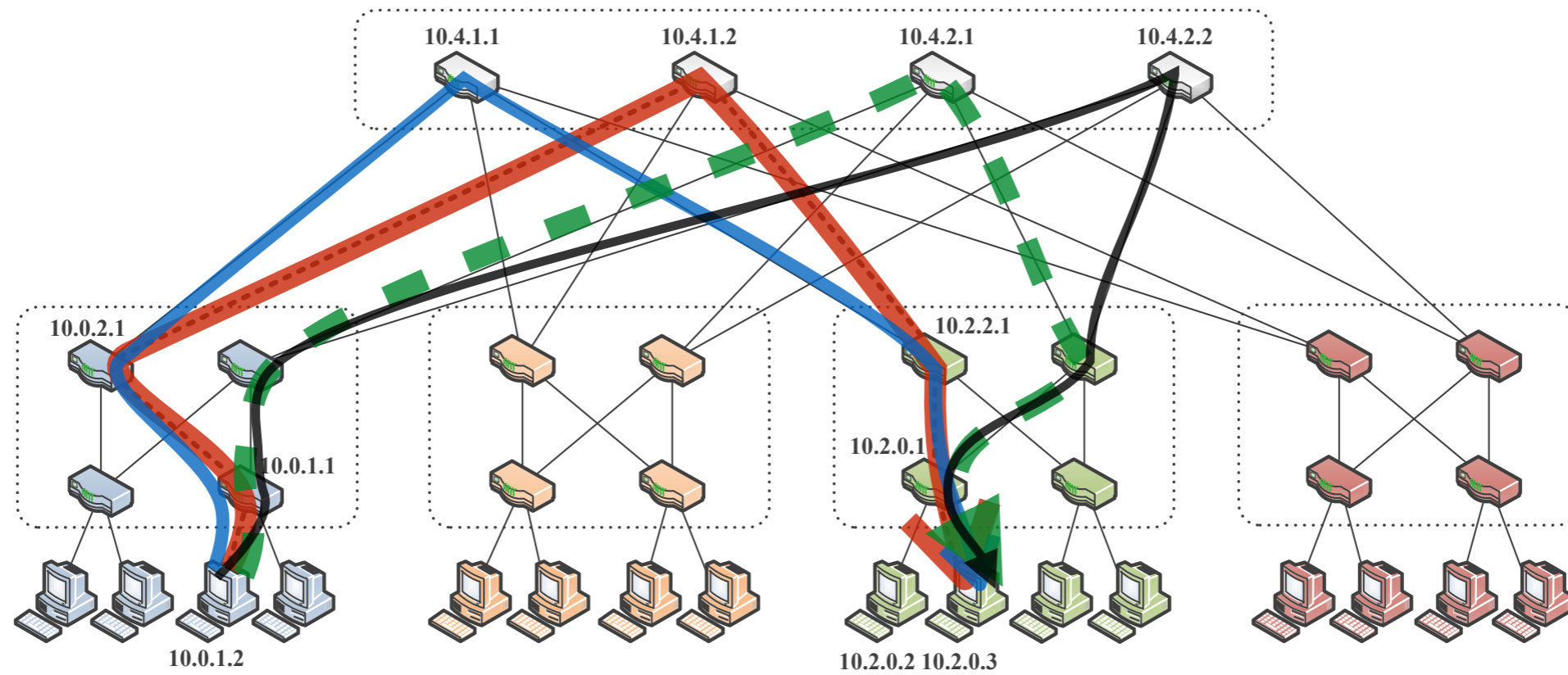

ECMP: traffic imbalance

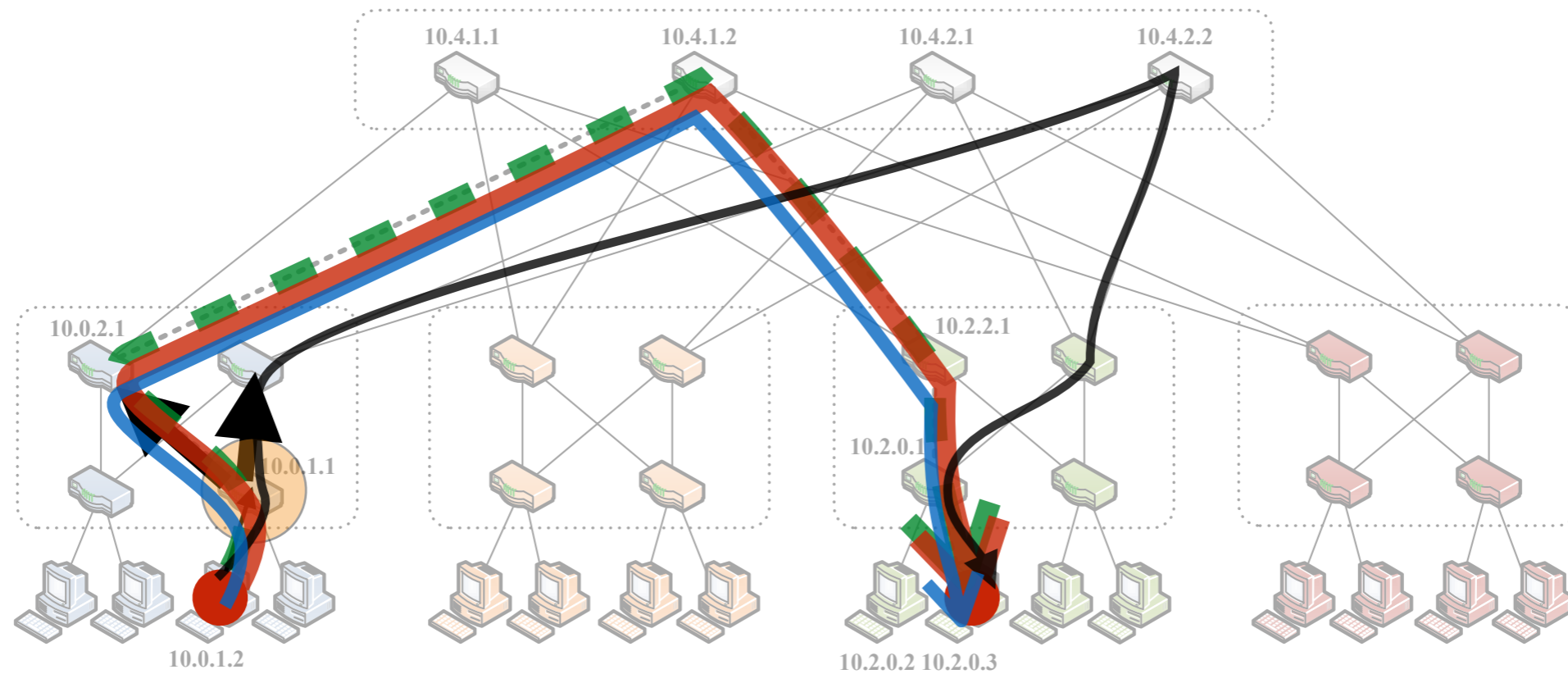

Output port = **hash** (packet header “5-tuple”)

IP src & dst.

Protocol number

Protocol port src & dst.

Flowlets

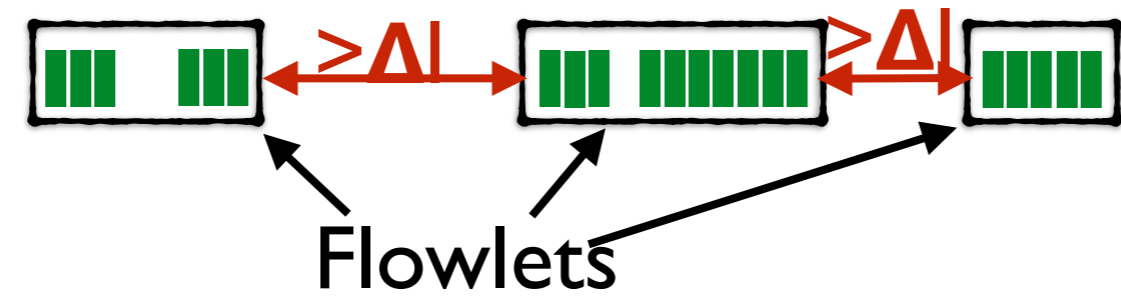
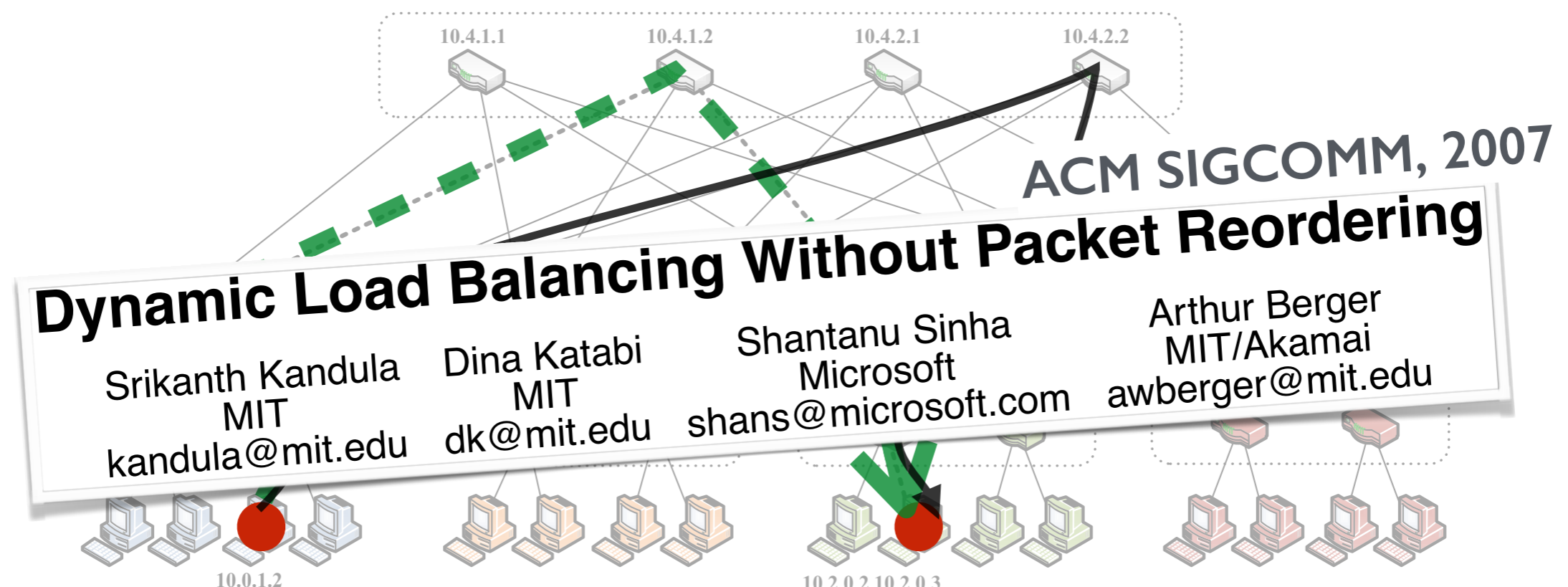

ECMP: local, oblivious choices

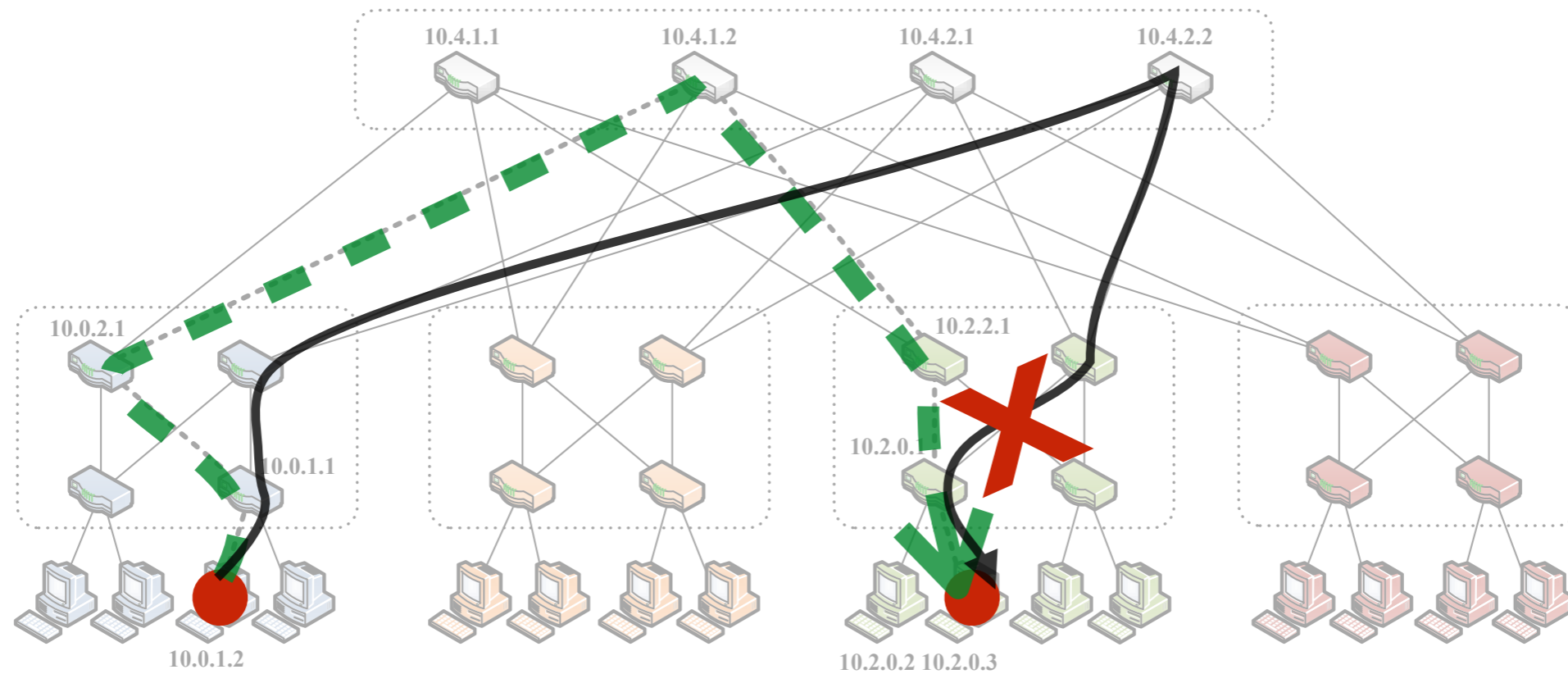

Cannot avoid distant failures!

CONGA: edge based monitoring



ACM SIGCOMM, 2014

CONGA: Distributed Congestion-Aware Load Balancing for Datacenters

Mohammad Alizadeh, Tom Edsall, Sarang Dharmapurikar, Ramanan Vaidyanathan, Kevin Chu,
Andy Fingerhut, Vinh The Lam (Google), Francis Matus, Rong Pan, Navindra Yadav,
George Varghese (Microsoft)

Cisco Systems

CONGA: edge based monitoring

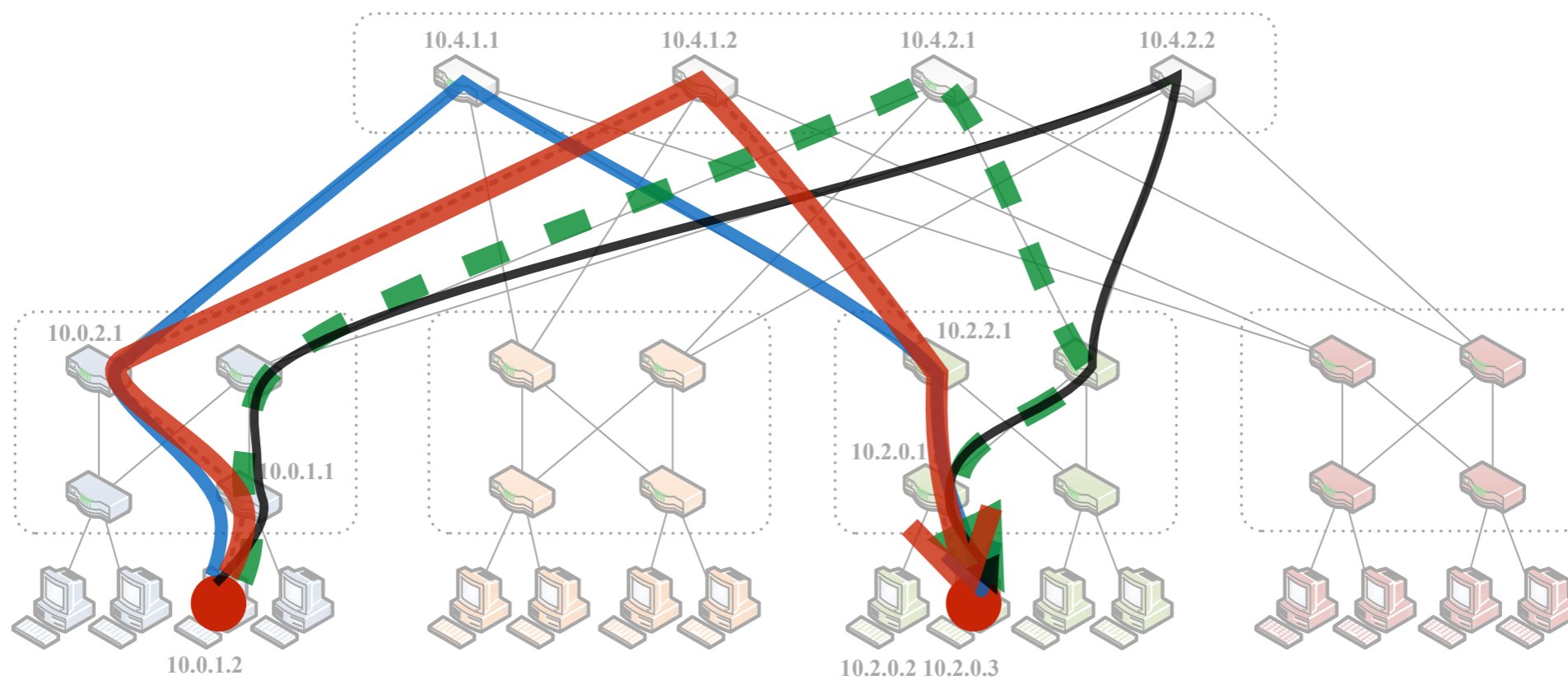

	Path 1	Path 2	Path 3	Path 4
Dest. switch	3	7	2	1



Physical layer

Topology

Load balancing

Transport

Control & SDN



National Petascale Computing Facility

- 1725 S Oak St., Champaign

Parking in Lot E-14 across Oak Street

- Illinois staff who have parking passes for any campus lot can park in this lot
- Guests can use the metered spots on the west edge of the lot just north of the Petascale facility. Requires coins or PayByPhone app.

Bus service

- Yellow and Gold buses run frequently to lot E-14
- Brown and Navy lines also