

SDN WAN Applications

Brighten Godfrey
CS 538 March 1, 2017

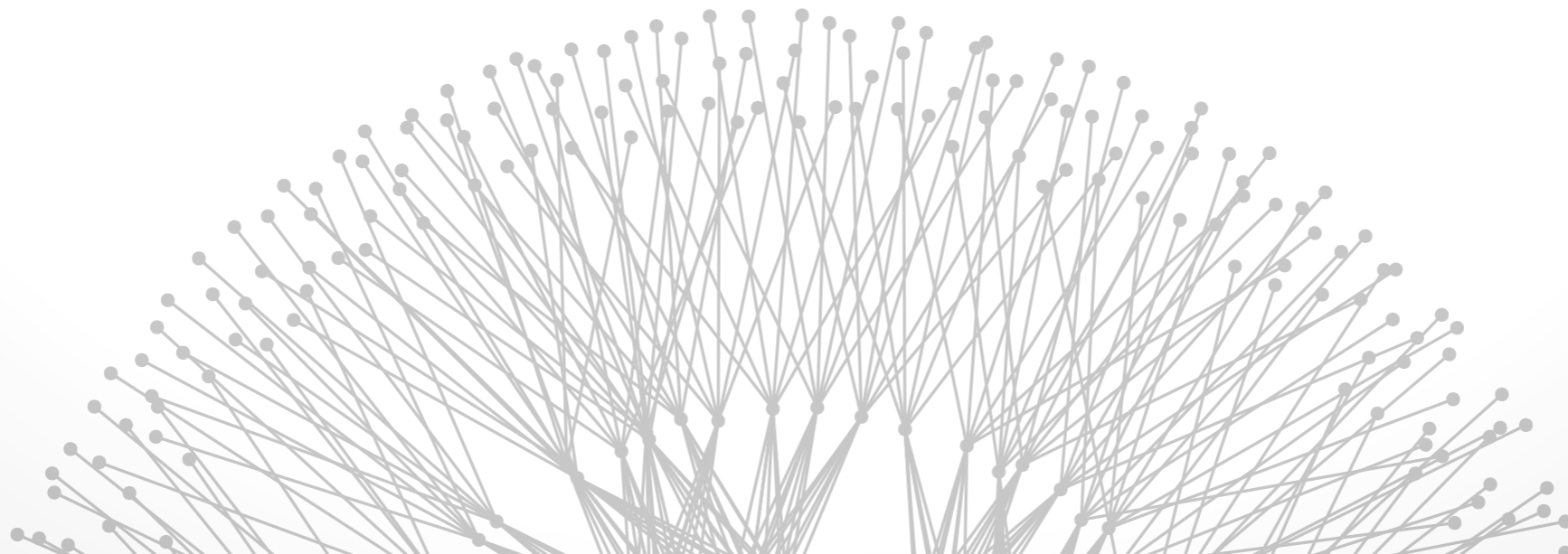

Initial “Killer apps”



Cloud virtualization

- Create separate virtual networks for tenants
- Allow flexible placement and movement of VMs

WAN traffic engineering

- Drive utilization to near 100% when possible
- Protect critical traffic from congestion

Key characteristics of the above

- Special-purpose deployments with less diverse hardware
- Existing solutions aren't just annoying, they don't work!

How large online services work



How large online services work

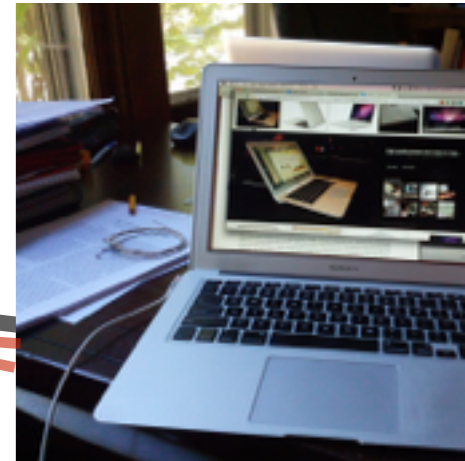
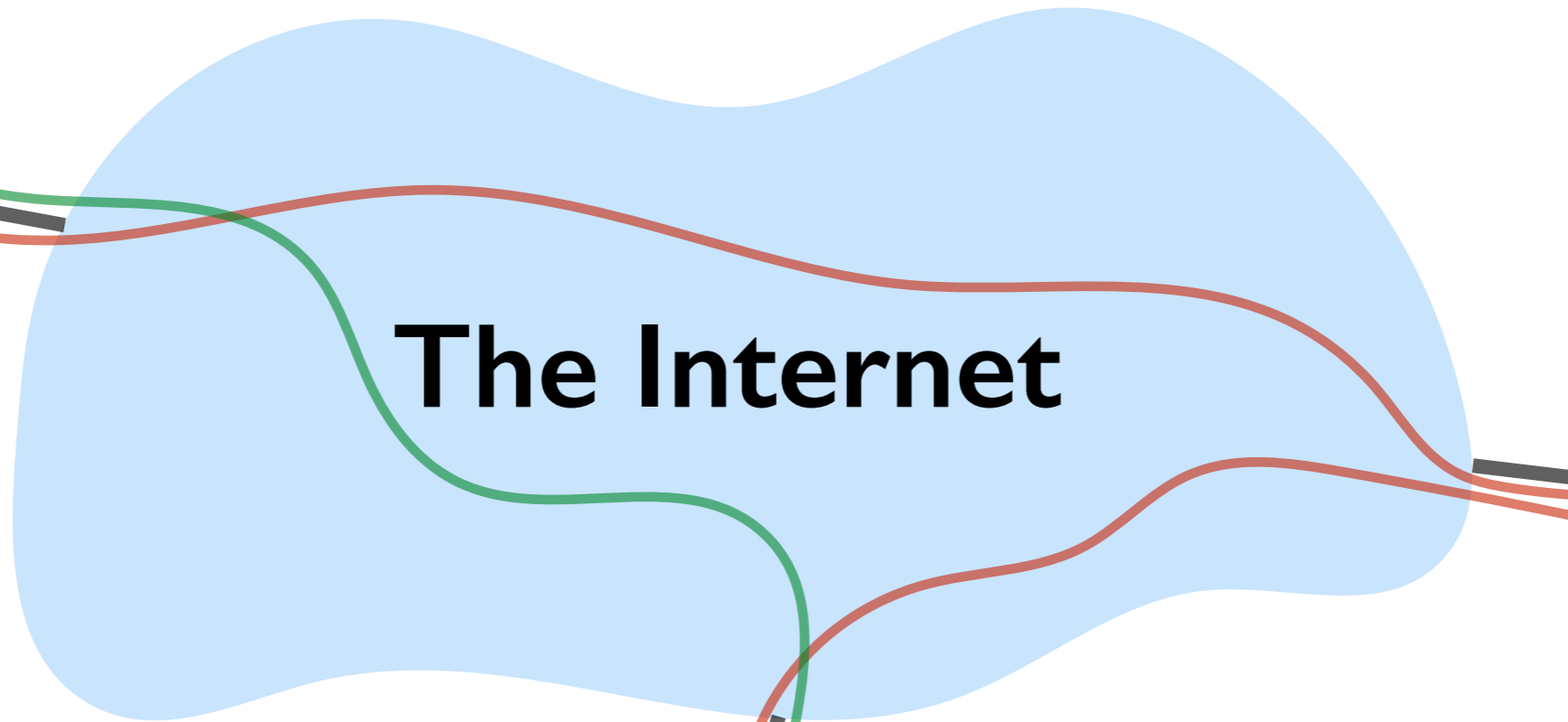

Why multiple data centers?



Data availability

Load balancing

Latency

Local data laws

Hybrid public-private operation

Inter-data center traffic is significant



IEEE INFOCOM, 2011

A First Look at Inter-Data Center Traffic Characteristics via Yahoo! Datasets

Yingying Chen¹, Sourabh Jain¹, Vijay Kumar Adhikari¹, Zhi-Li Zhang¹, and Kuai Xu²

¹University of Minnesota-Twin Cities

²Arizona State University

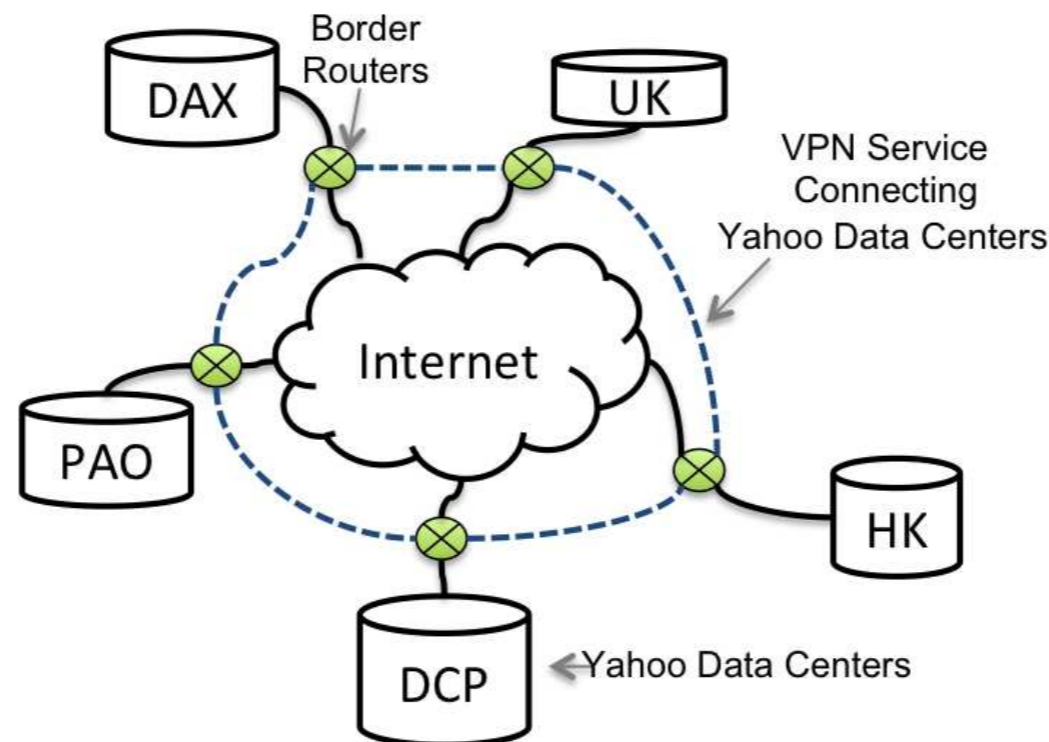

Inter-data center traffic is significant



IEEE INFOCOM, 2011

A First Look at Inter-Data Center Traffic Characteristics via Yahoo! Datasets

Yingying Chen¹, Sourabh Jain¹, Vijay Kumar Adhikari¹, Zhi-Li Zhang¹, and Kuai Xu²

¹University of Minnesota-Twin Cities

²Arizona State University

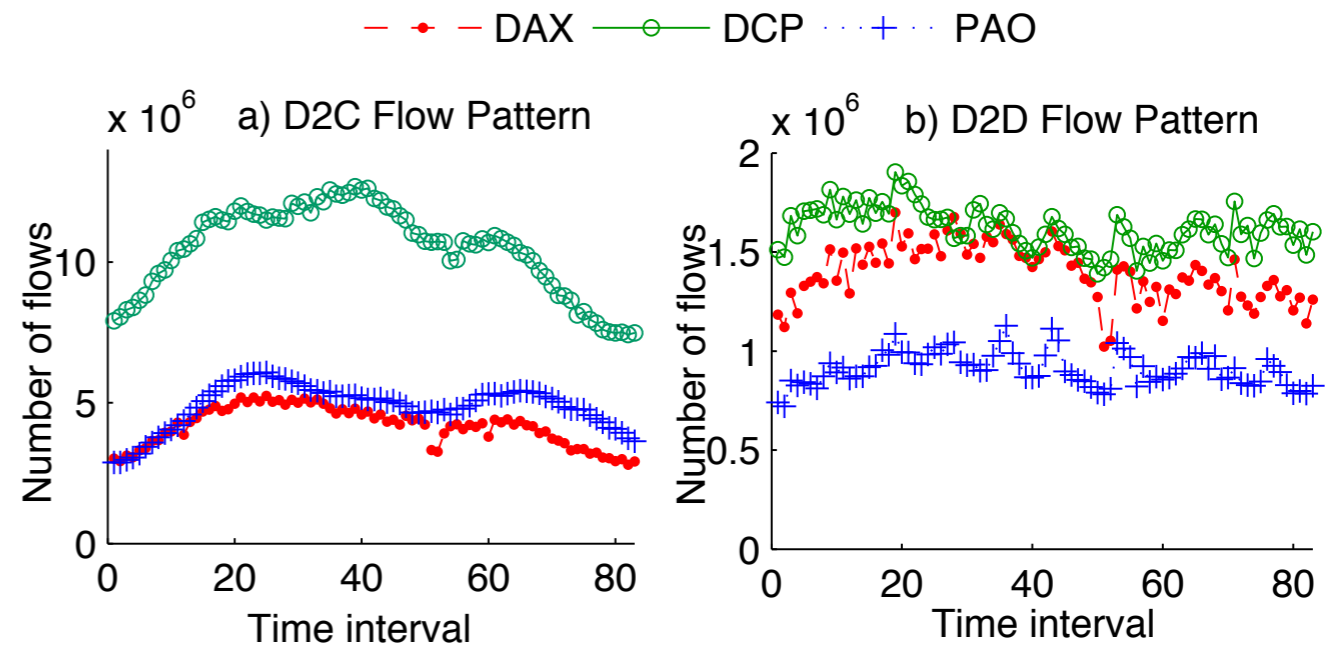
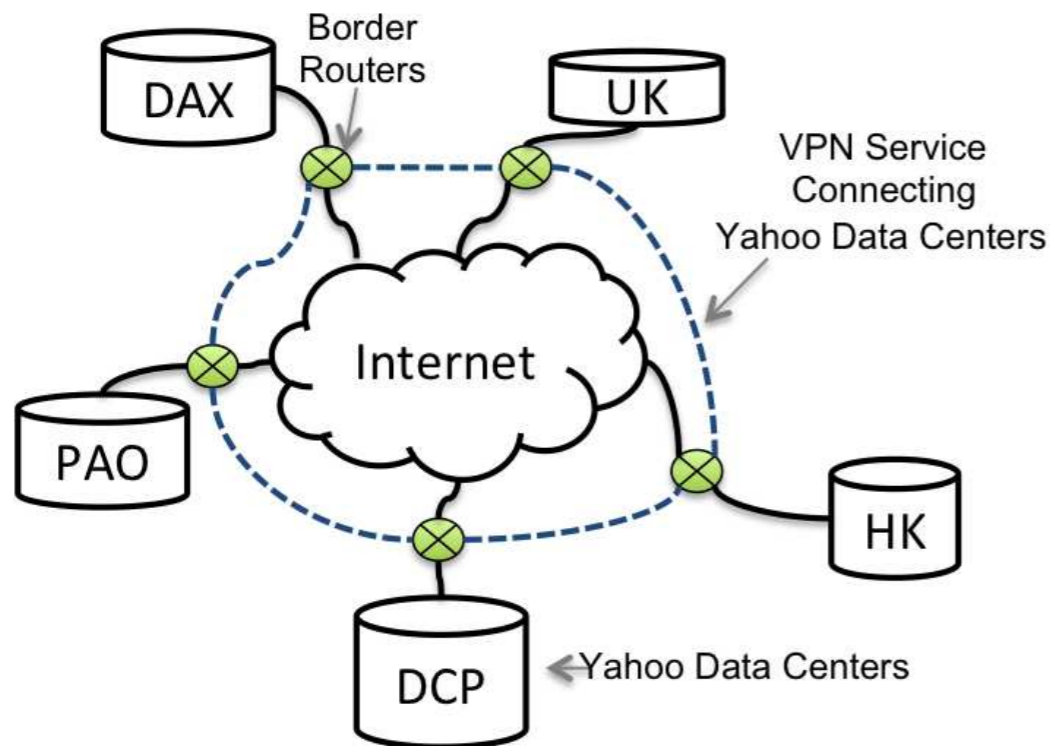

Inter-data center traffic is significant



Back-Office Web Traffic on The Internet

Enric Pujol
TU Berlin
enric@inet.tu-berlin.de

Philipp Richter
TU Berlin
prichter@inet.tu-berlin.de

Balakrishnan Chandrasekaran
Duke University
balac@cs.duke.edu

Georgios Smaragdakis
MIT / TU Berlin / Akamai
gsmaragd@csail.mit.edu

Anja Feldmann
TU Berlin
anja@inet.tu-berlin.de

Bruce Maggs
Duke / Akamai
bmm@cs.duke.edu

Keung-Chi Ng
Akamai
kng@akamai.com

[IMC 2014]

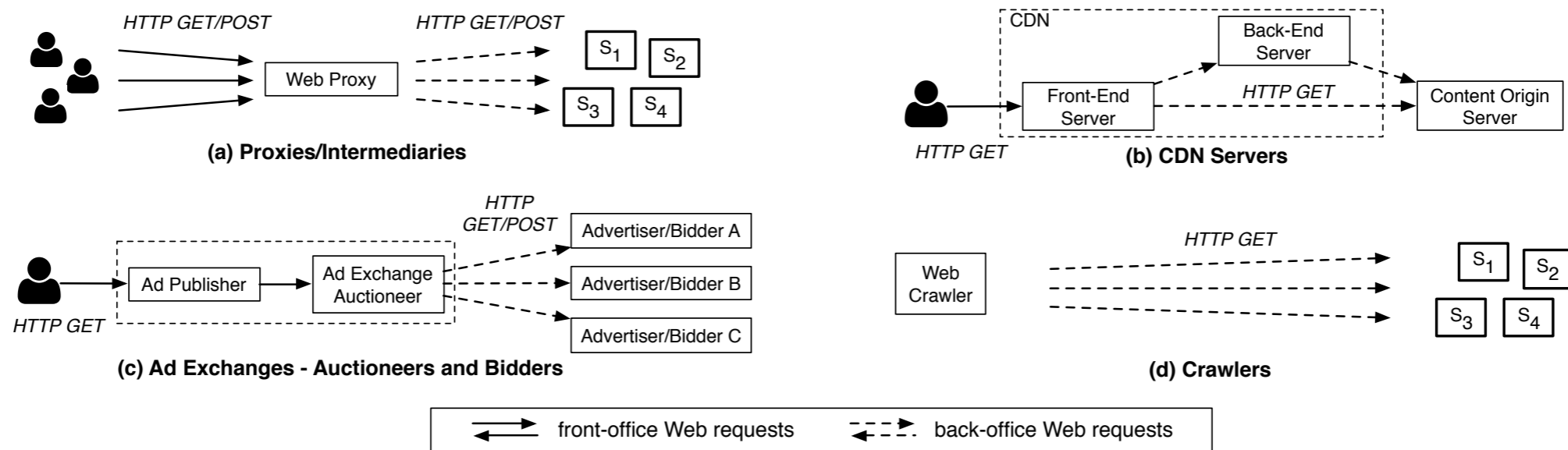

“Back office” web traffic:
server-to-server rather than
directly communicating with user

Inter-data center traffic is significant



Back-Office Web Traffic on The Internet

<p>Enric Pujol TU Berlin enric@inet.tu-berlin.de</p> <p>Georgios Smaragdakis MIT / TU Berlin / Akamai gsmaragd@csail.mit.edu</p>	<p>Philipp Richter TU Berlin prichter@inet.tu-berlin.de</p> <p>Anja Feldmann TU Berlin anja@inet.tu-berlin.de</p>	<p>Balakrishnan Chandrasekaran Duke University balac@cs.duke.edu</p> <p>Bruce Maggs Duke / Akamai bmm@cs.duke.edu</p>	<p>Keung-Chi Ng Akamai kng@akamai.com</p>
--	---	---	---

[IMC 2014]

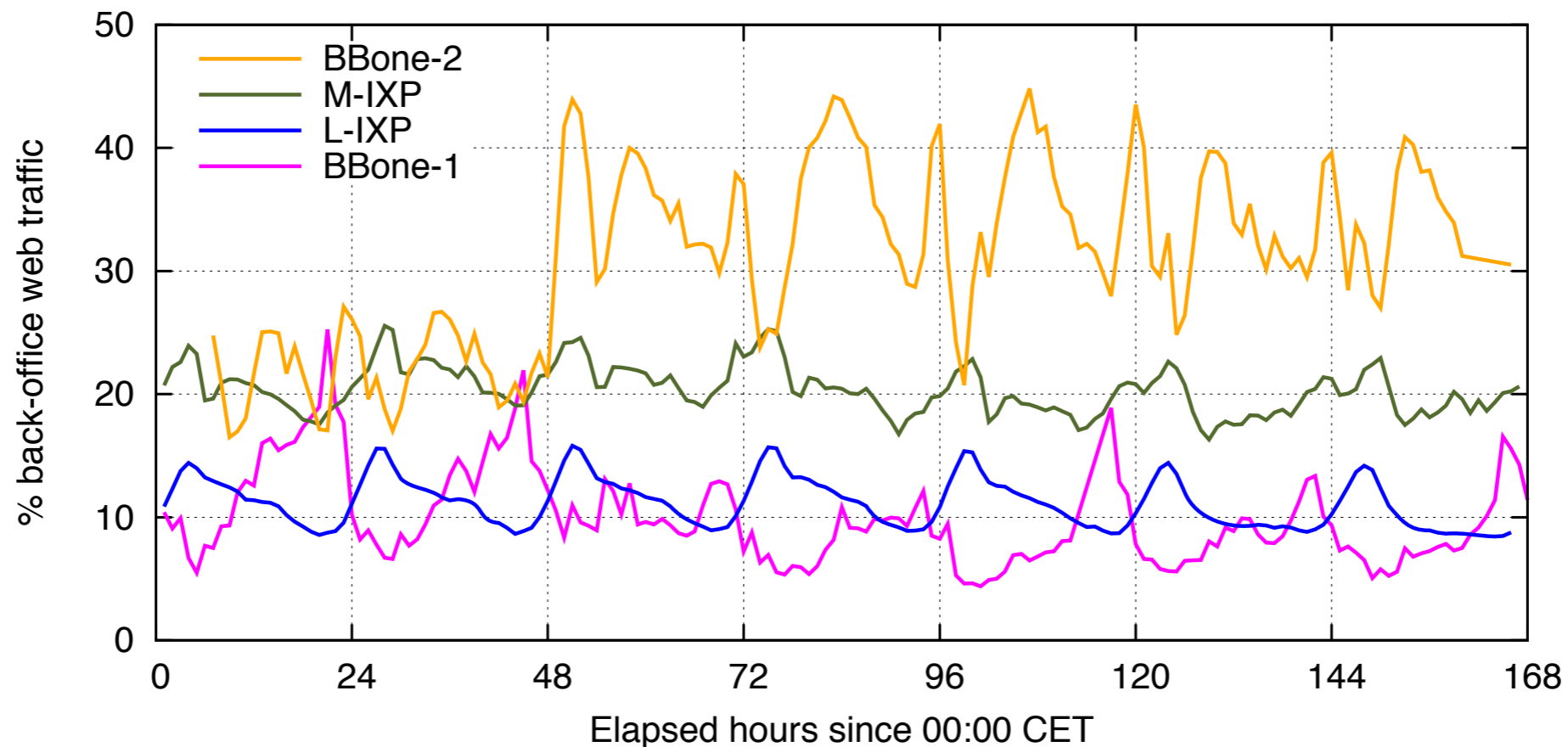
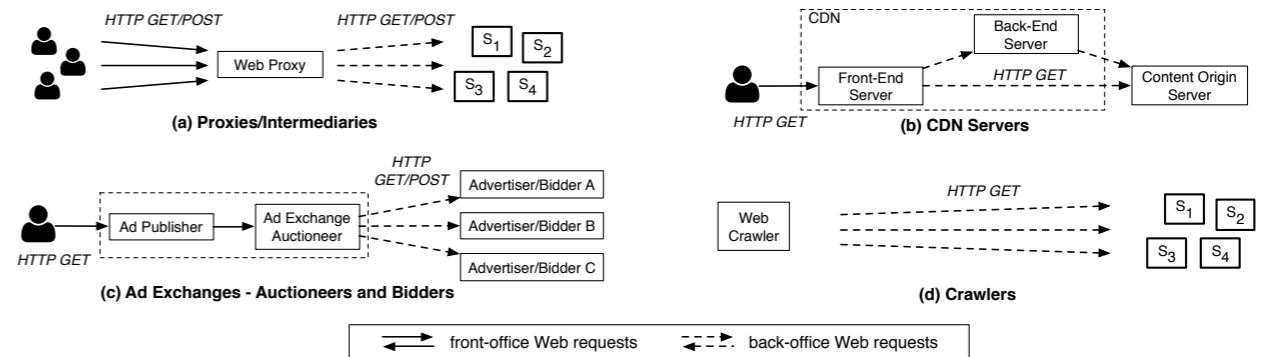

% of web traffic that is “back office” in 4 ISP, IXP data sets

Google's WAN (2011)



“B4: Experience with a Globally-Deployed Software Defined WAN”

Jain et al., ACM SIGCOMM 2013



“B4 has been in deployment for three years, now carries more traffic than Google’s public facing WAN, and has a higher growth rate.”

Traditional WAN approach: MPLS

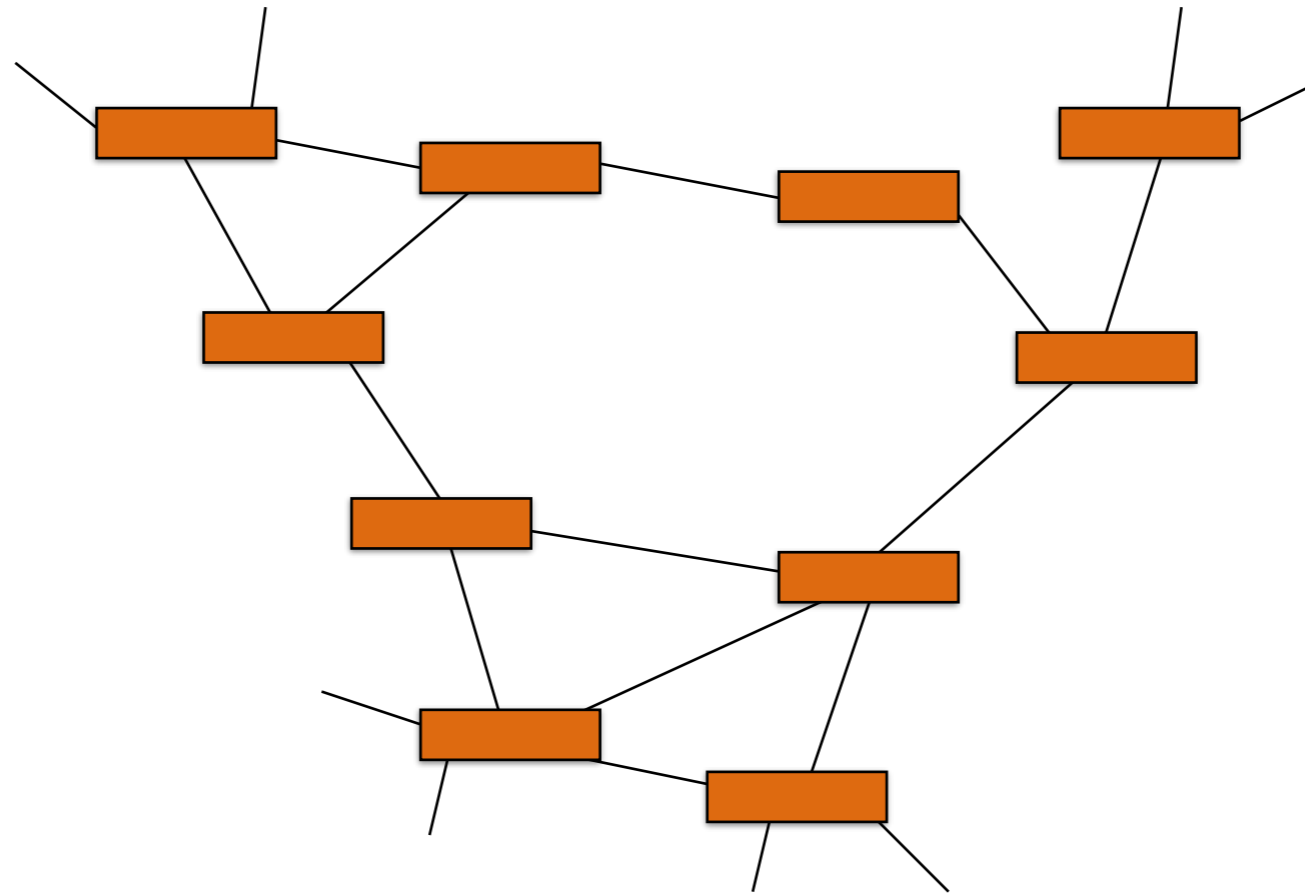

Traditional WAN approach: MPLS

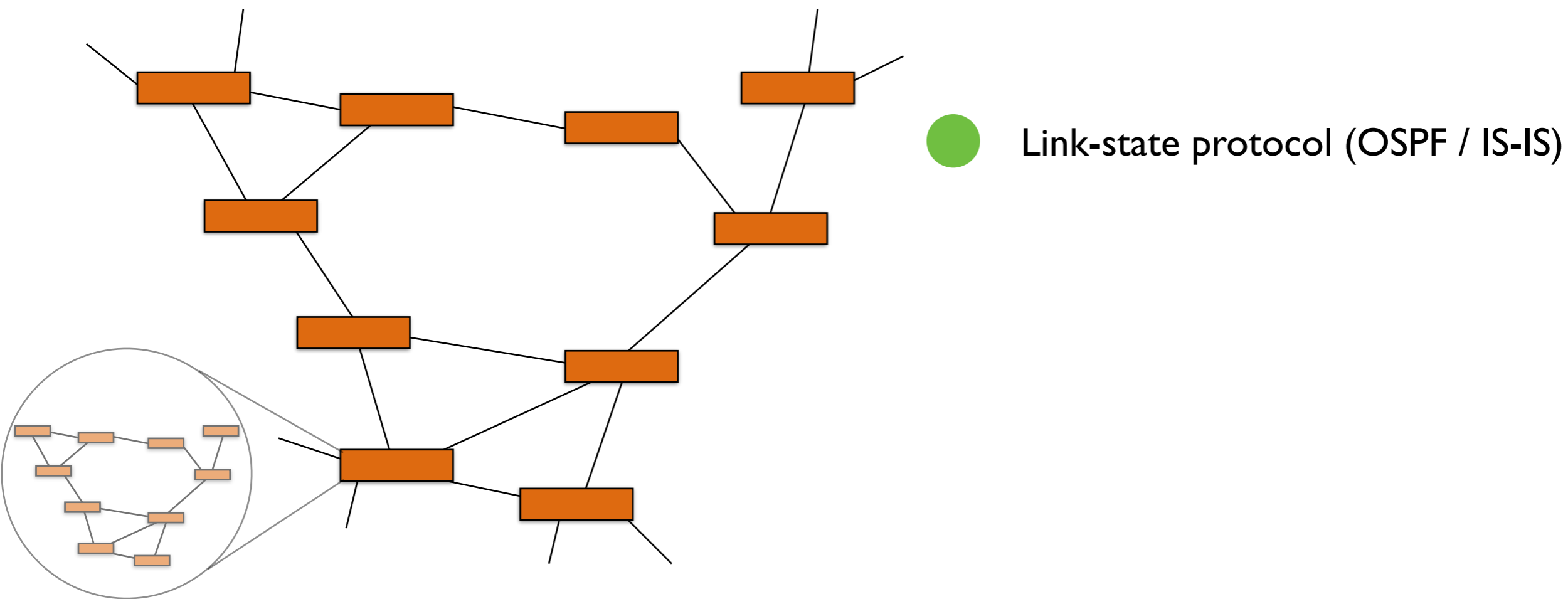

Traditional WAN approach: MPLS

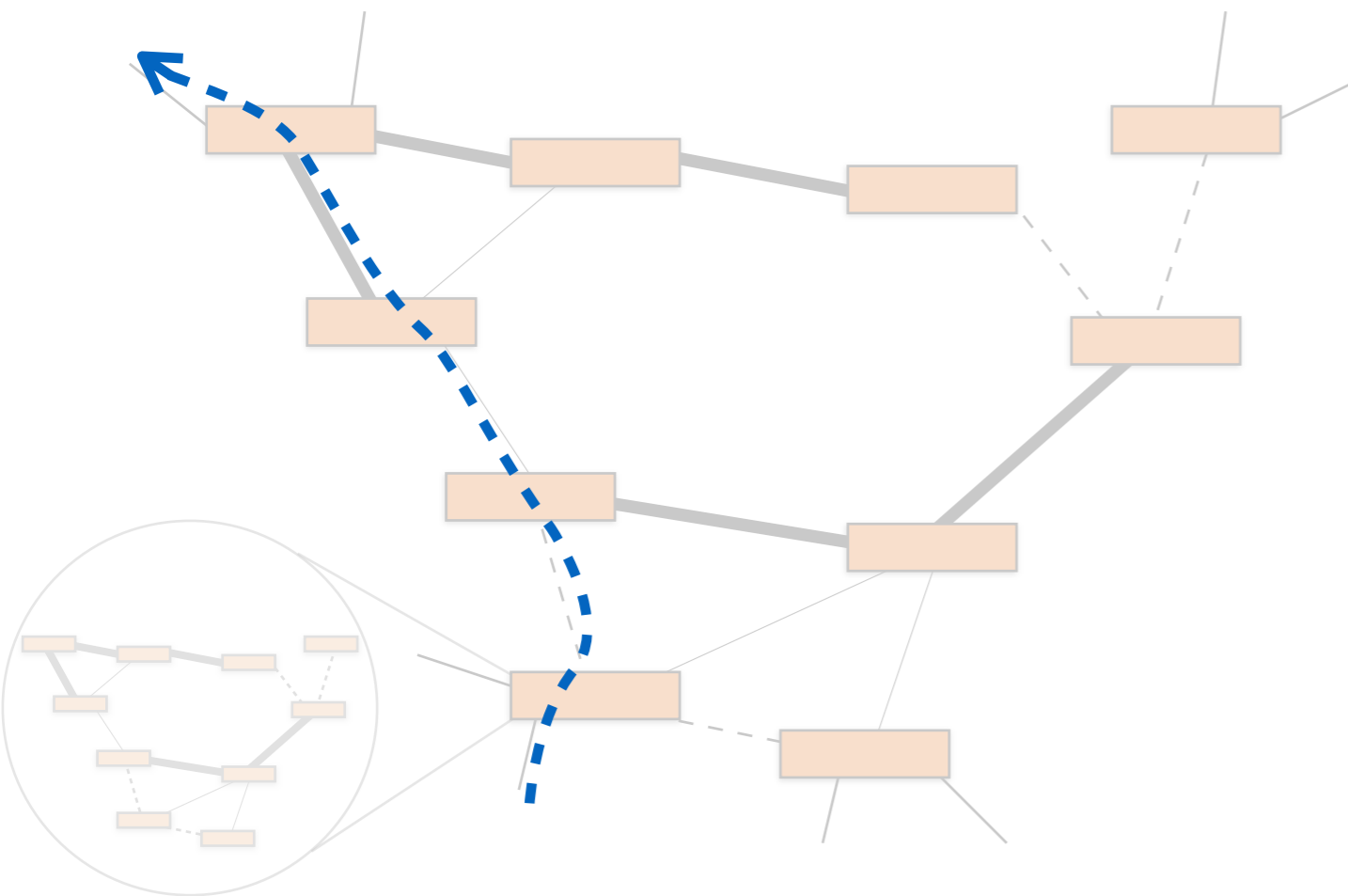

- Link-state protocol (OSPF / IS-IS)
- Also flood available bandwidth info
- Fulfill tunnel provisioning requests

Traditional WAN approach: MPLS

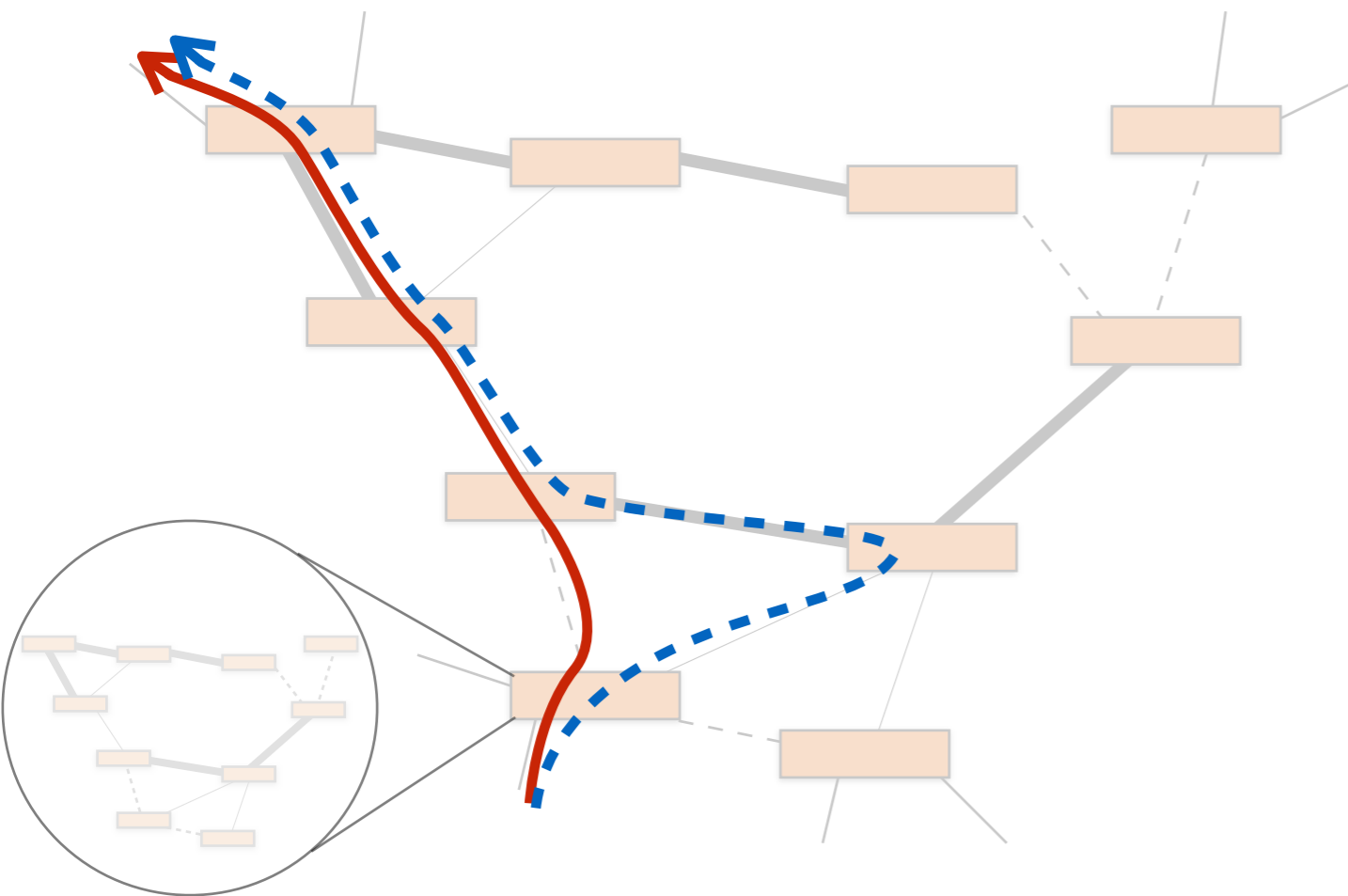

- Link-state protocol (OSPF / IS-IS)
- Also flood available bandwidth info
- Fulfill tunnel provisioning requests
- Update network state, flood info

Traditional WAN approach: MPLS

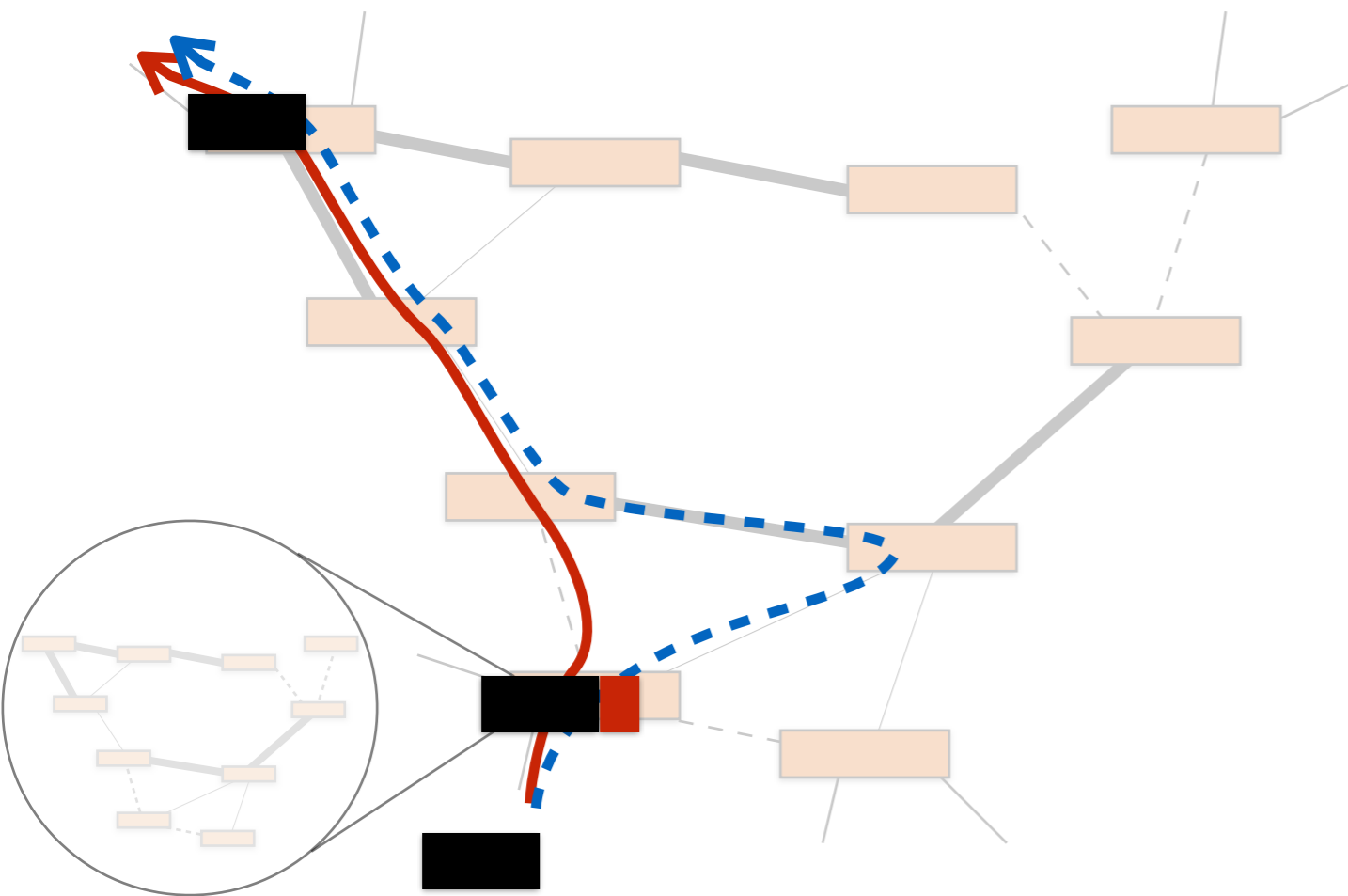

- Link-state protocol (OSPF / IS-IS)
- Also flood available bandwidth info
- Fulfill tunnel provisioning requests
- Update network state, flood info

Problem 1: inefficiency



ACM SIGCOMM, 2013

Achieving High Utilization with Software-Driven WAN

Chi-Yao Hong (UIUC) Srikanth Kandula Ratul Mahajan Ming Zhang
Vijay Gill Mohan Nanduri Roger Wattenhofer (ETH)

Microsoft

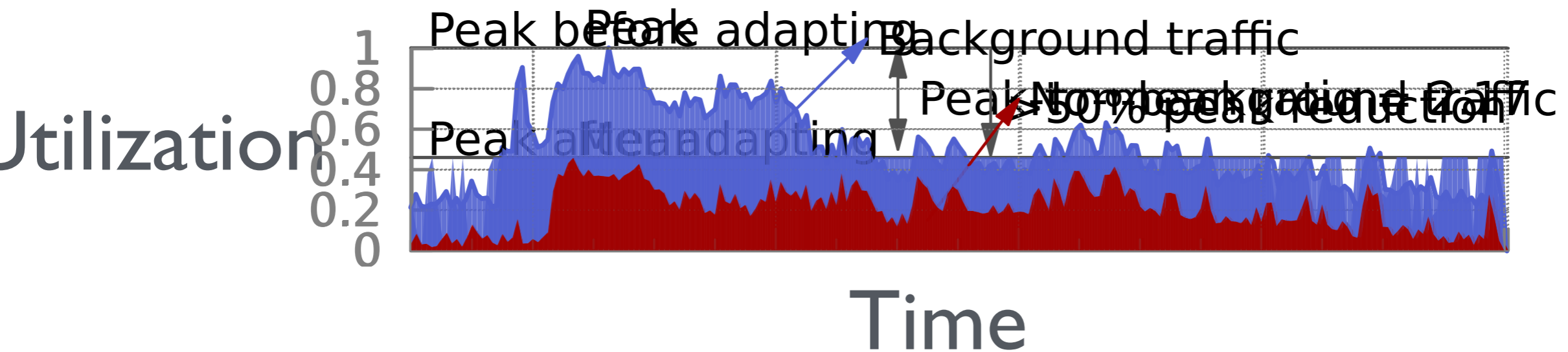

Problem 2: inflexible sharing

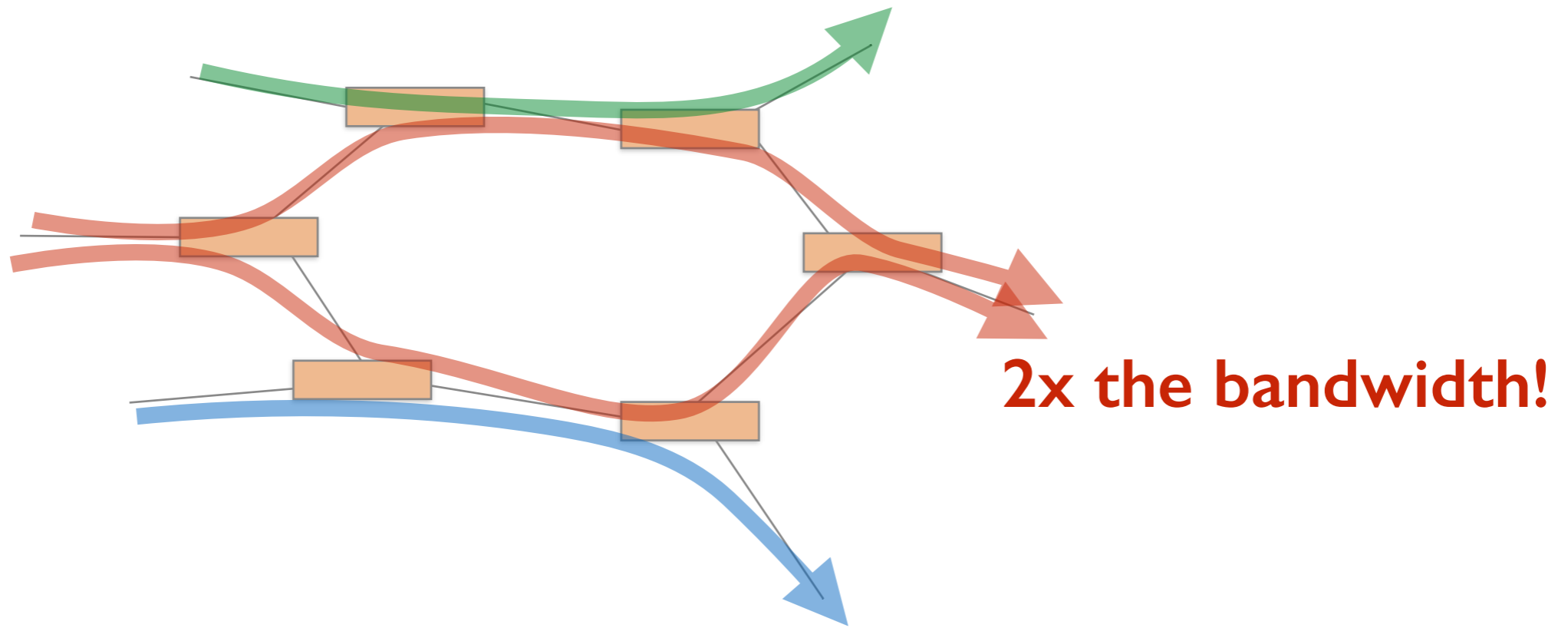

B4 key design decisions



[Jain et al., SIGCOMM 2013]

Separate hardware from software

B4 routers custom-built from merchant silicon

Drive links to 100% utilization

Centralized traffic engineering

Google's B4



“B4: Experience with a Globally-Deployed Software Defined WAN”

Jain et al., ACM SIGCOMM 2013



Google's B4



“B4: Experience with a Globally-Deployed Software Defined WAN”
Jain et al., ACM SIGCOMM 2013

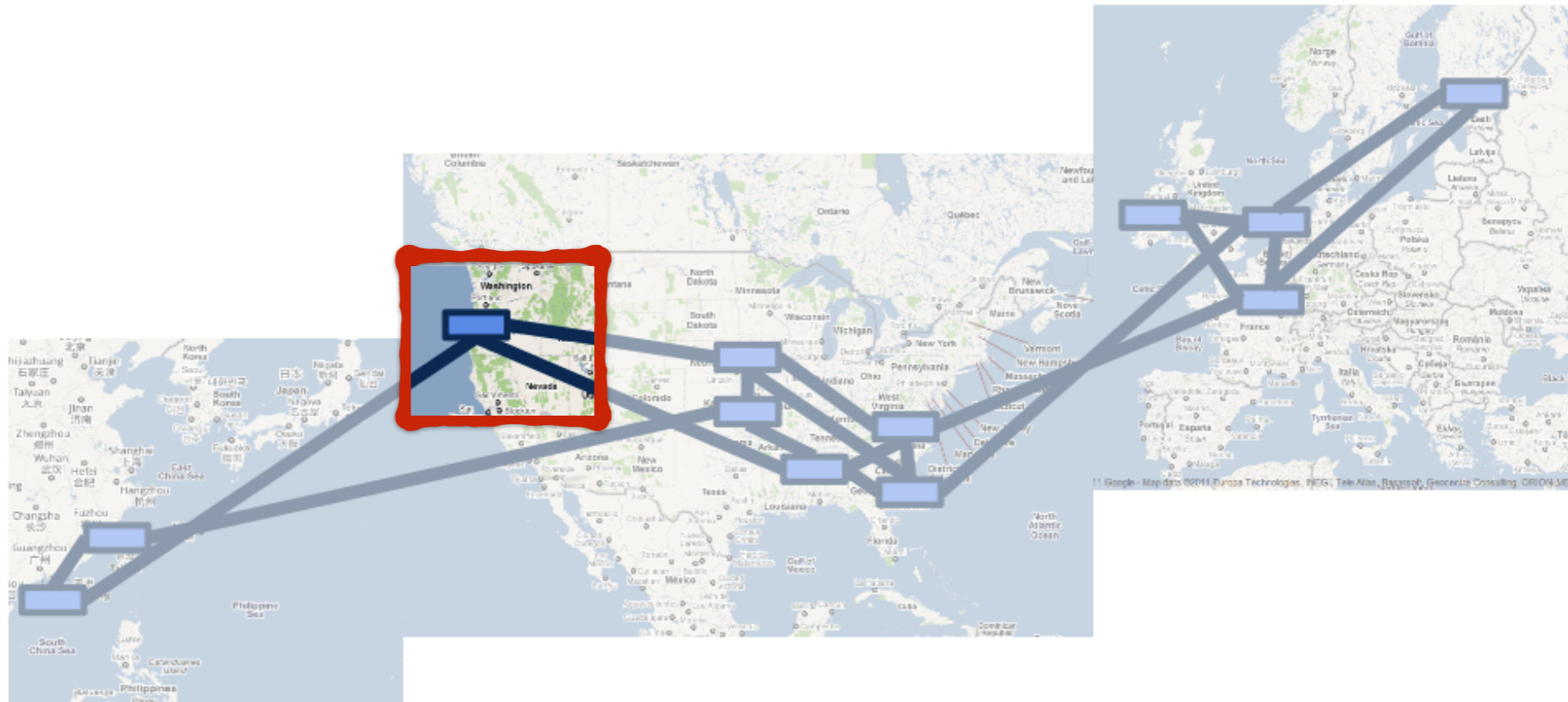

Google's B4: view at one site

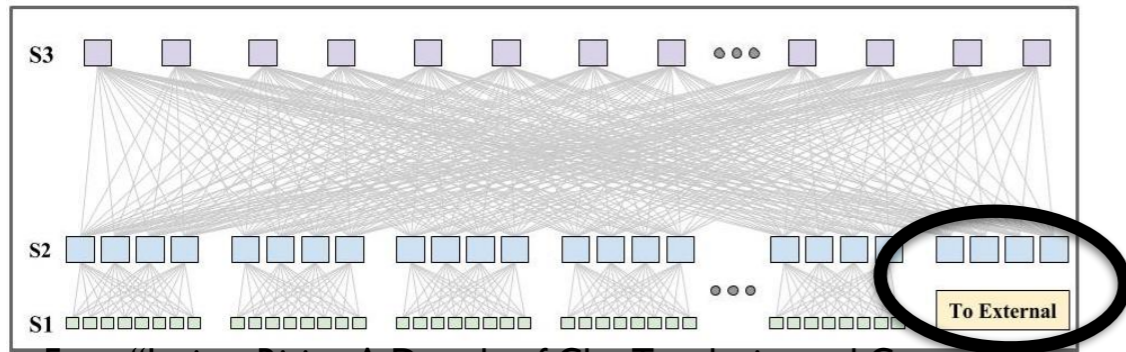

From "Jupiter Rising: A Decade of Clos Topologies and Centralized Control in Google's Datacenter Network", Singh et al., ACM SIGCOMM'15

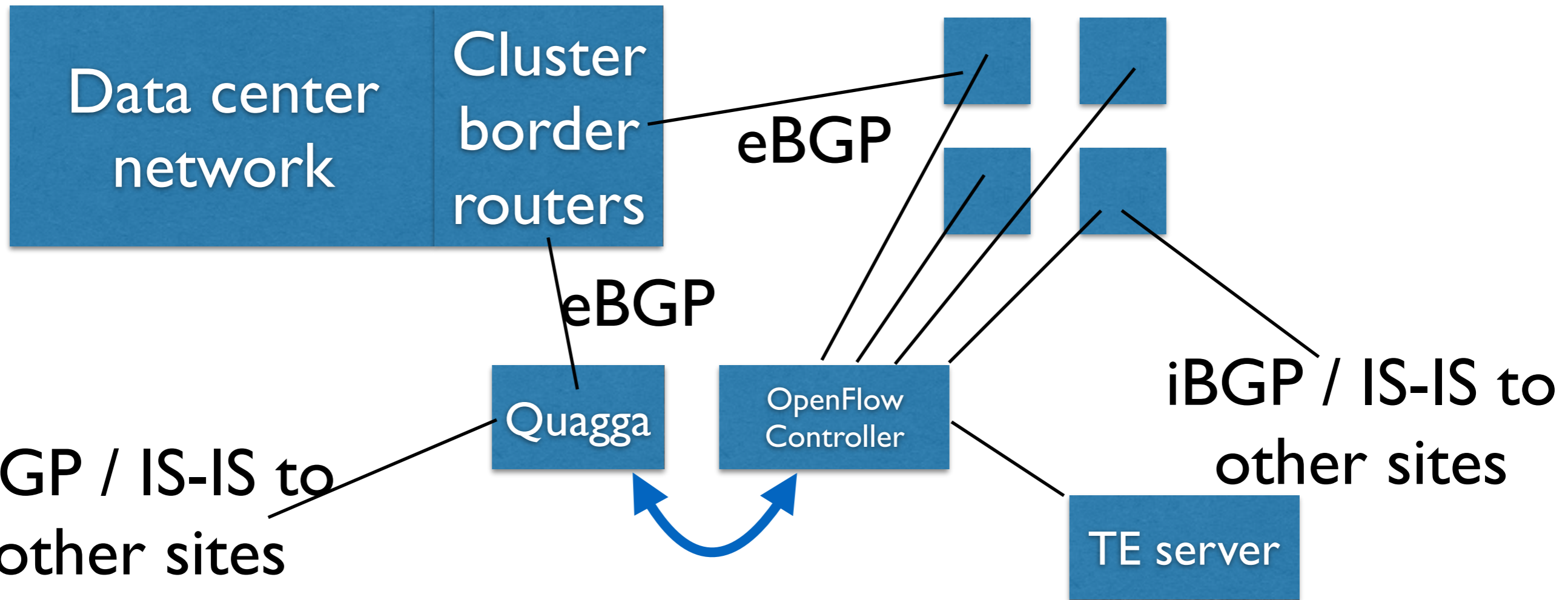

Google's B4: Traffic engineering

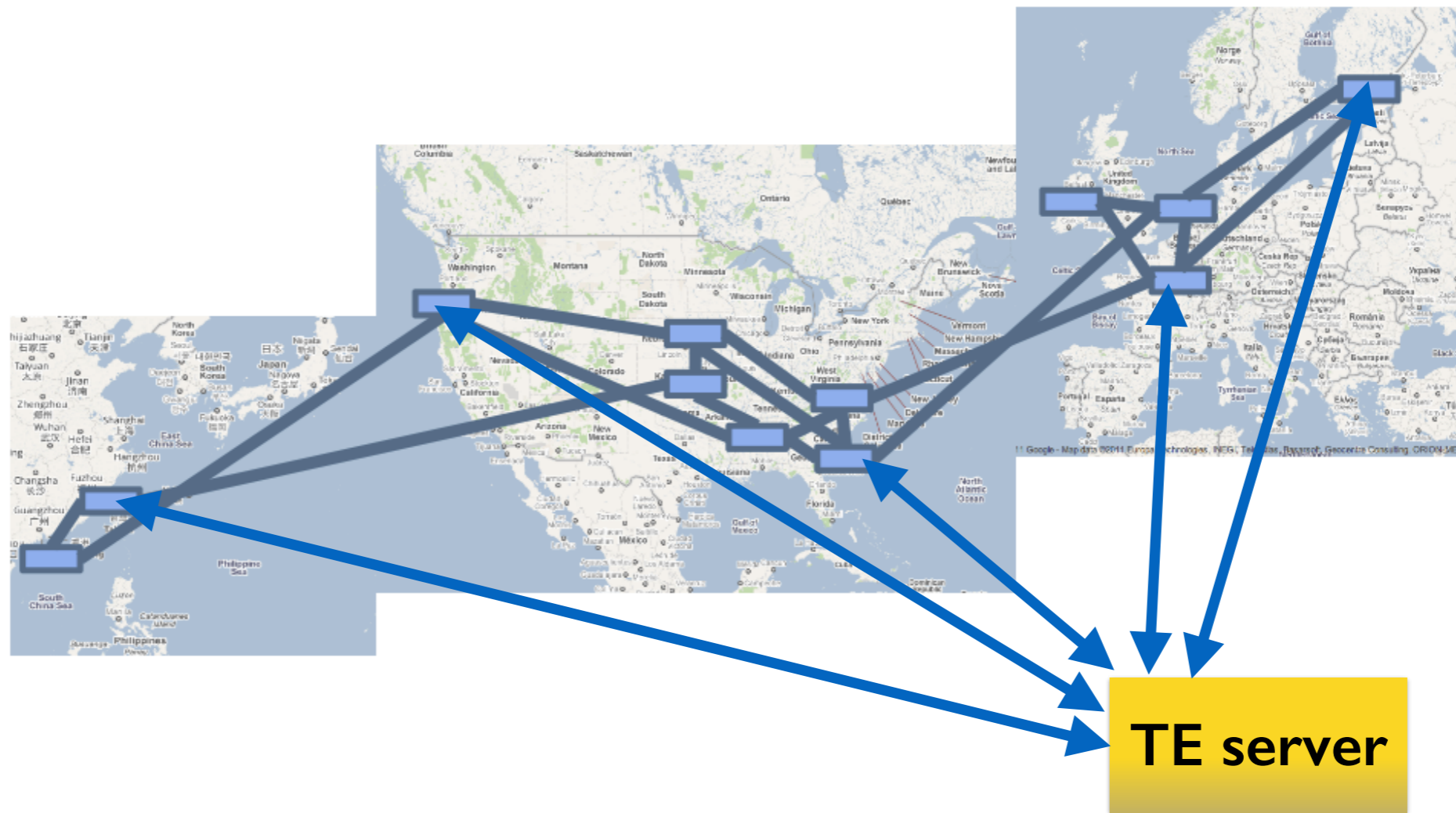

Vs. Semi-Distributed TE



What aspects of B4 would have been difficult with MPLS-based TE such as TeXCP?

What aspects of B4 are similar to TeXCP?



1 How does B4 scale?

- Subsecond centralized scheduling of more traffic than Google's public WAN serves!

2 What does B4 assume about network's traffic?

- In what environments would these assumptions be violated?
- In what other environments would they be valid?

How does B4 scale?



How does B4 scale?



Hierarchy

- Not a simple controller-to-switch design!

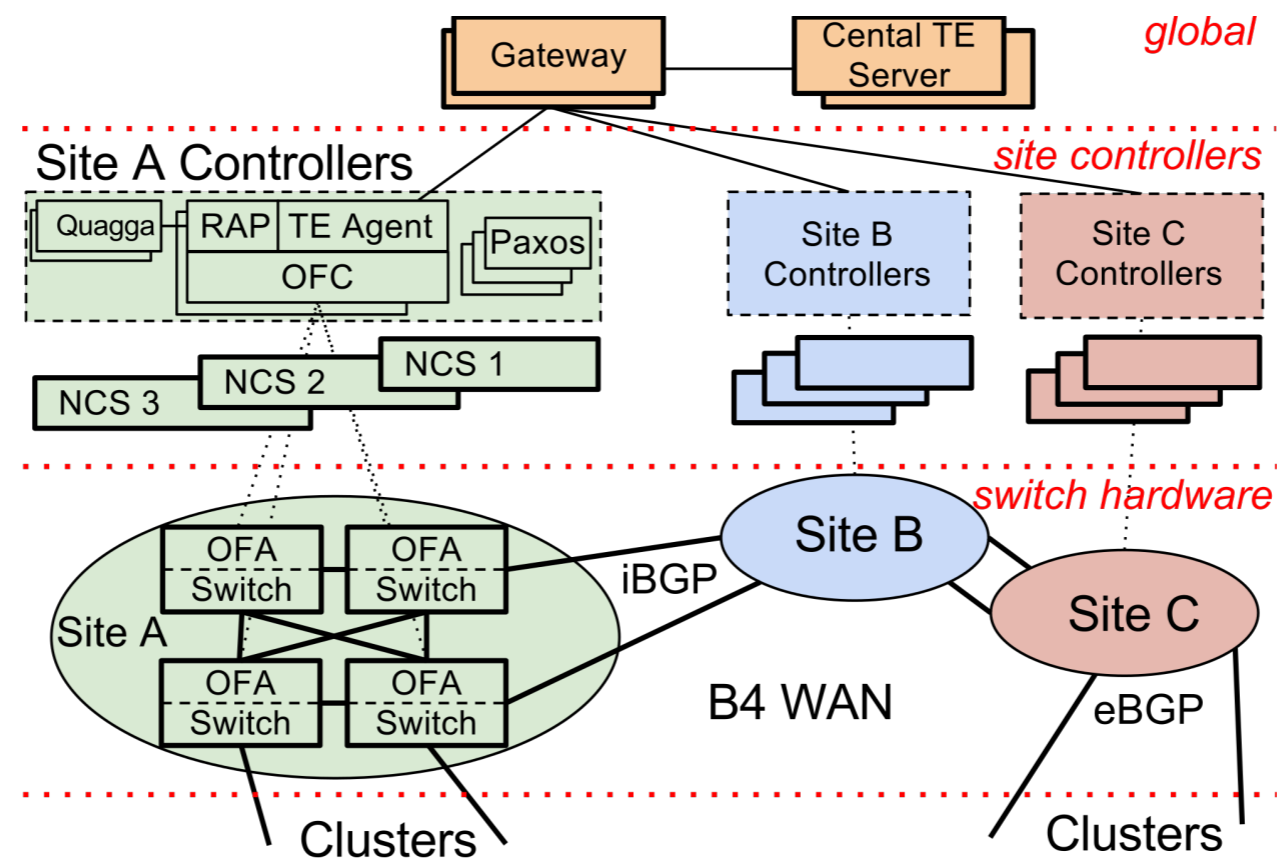

Figure 2: B4 architecture overview.

How does B4 scale?



Hierarchy

- Not a simple controller-to-switch design!

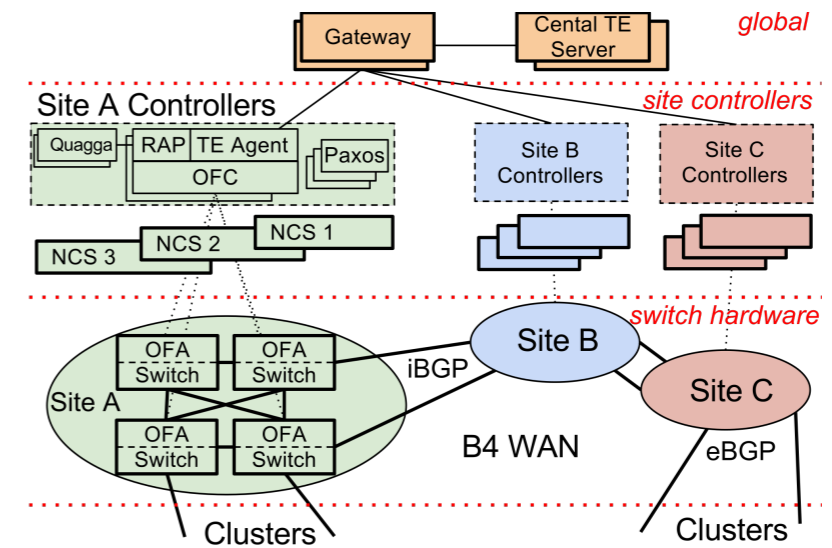

Figure 2: B4 architecture overview.

How does B4 scale?



Hierarchy

- Not a simple controller-to-switch design!

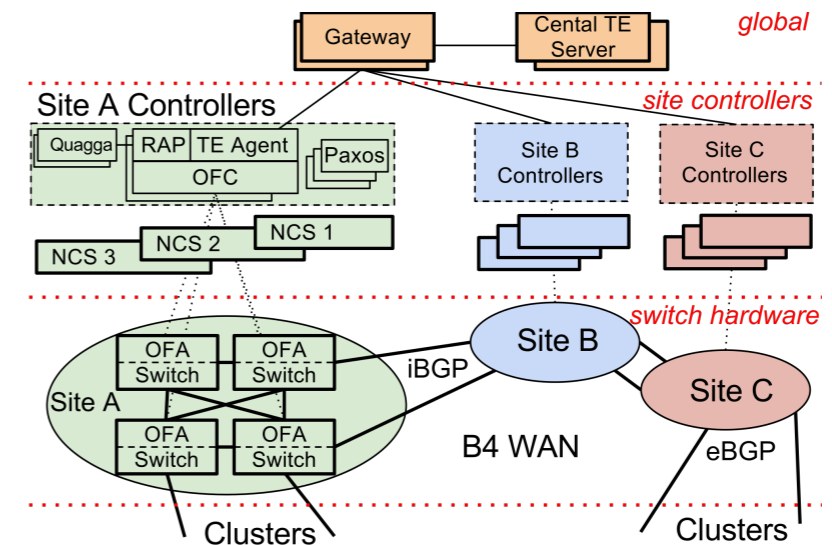

Figure 2: B4 architecture overview.

Aggregation

- Node = site (data center)
- Link = 100s of links
- Flow group = {src, dst, QoS} tuple



Figure 1: B4 worldwide deployment (2011).

How does B4 scale?



Hierarchy

- Not a simple controller-to-switch design!

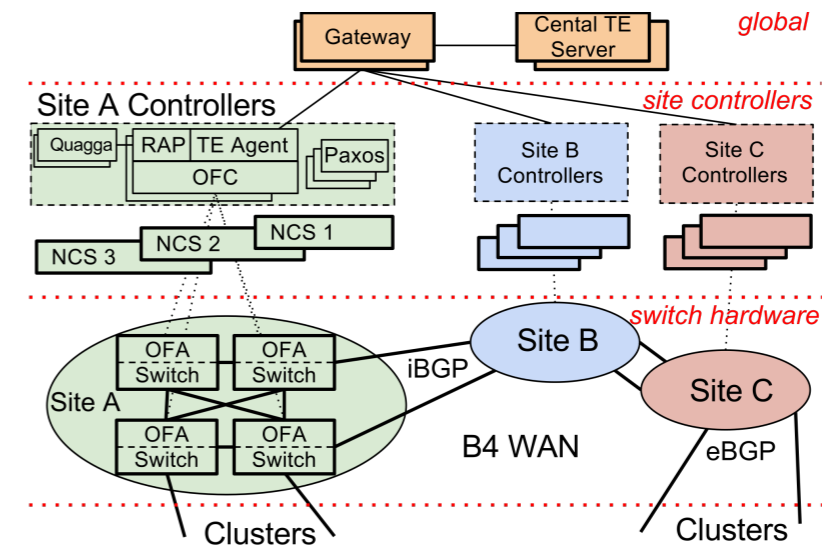

Figure 2: B4 architecture overview.

Aggregation

- Node = site (data center)
- Link = 100s of links
- Flow group = {src, dst, QoS} tuple



Figure 1: B4 worldwide deployment (2011).

Algorithms

- Greedy heuristic approximation algorithm

What assumptions about traffic?



Design makes what assumption about traffic to approach 100% utilization on some links?

- High priority traffic is in the minority
- Elastic traffic is the majority (backups, offline data analytics, ...)

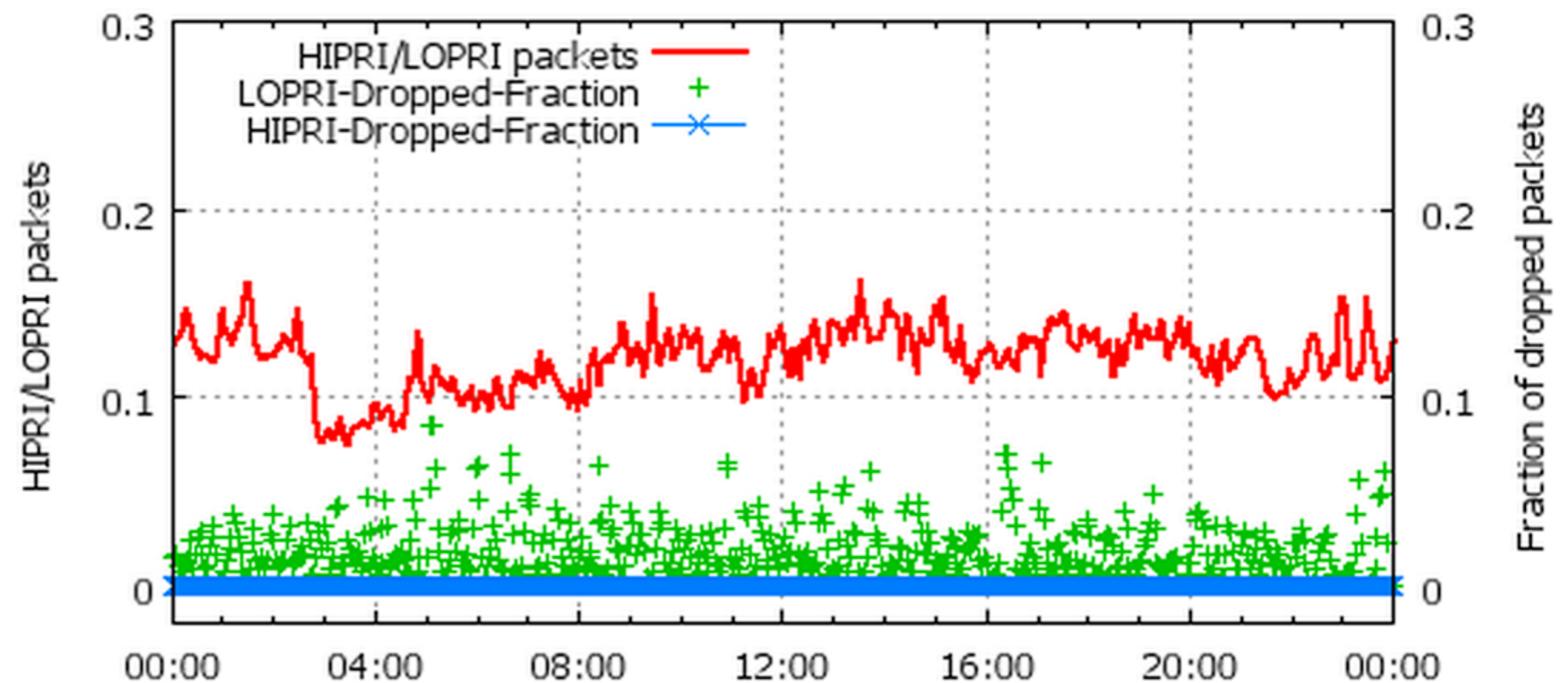

What assumptions about traffic?



Design makes what assumption about traffic to approach 100% utilization on some links?

- High priority traffic is in the minority
- Elastic traffic is the majority (backups, offline data analytics, ...)

When would that assumption be violated?

- Google's user-facing wide area network