

CS/ECE 439: Wireless Networking

Physical Layer

Limitation (of Wireless) Communication



Wireless Networks Builds on ...

▶ General networking

- ▶ Internet architecture: who is responsible for what?
- ▶ How is it affected by wireless links or congestion in wireless multi-hop networks?
- ▶ How is it affected by mobility?
- ▶ How about variable link properties and intermittent connectivity?

▶ Wireless communications

- ▶ How does signal environment affect performance of a wireless link?
- ▶ What wireless communication challenges can be hidden from higher layer protocols?



RF Introduction

- ▶ RF = Radio Frequency
 - ▶ Electromagnetic signal that propagates through “ether”
 - ▶ Ranges 3 KHz .. 300 GHz
 - ▶ Or 100 km .. 0.1 cm (wavelength)

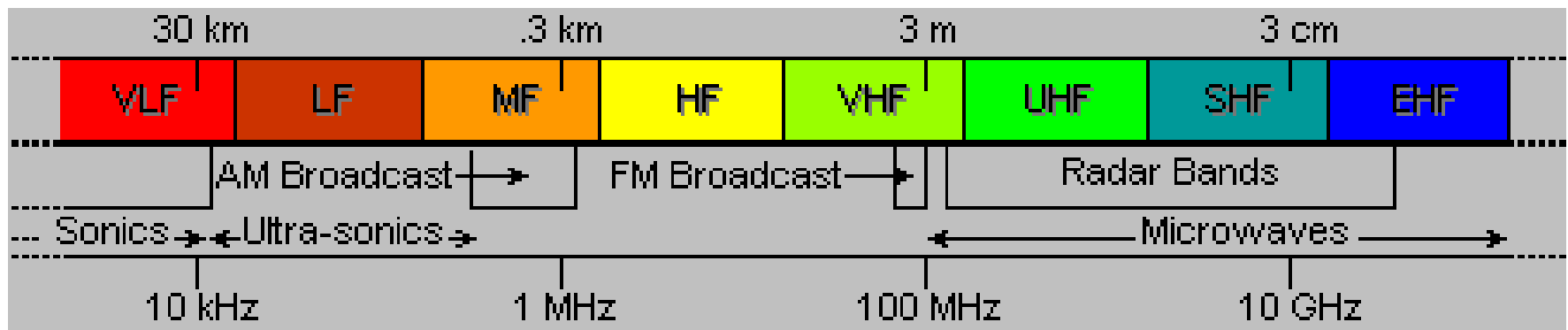

- ▶ Travels at the speed of light
- ▶ Can take both a time and a frequency view

Cartoon View 1 – Energy Wave

- ▶ Think of it as energy that radiates from one antenna and is picked up by another antenna
 - ▶ Helps explain properties such as attenuation
 - ▶ Density of the energy reduces over time and with distance
- ▶ Useful when studying attenuation
 - ▶ Receiving antennas catch less energy with distance
 - ▶ Notion of cellular infrastructure



Cartoon View 2 – Rays of Energy

- ▶ Can also view it as a “ray” that propagates between two points
 - ▶ Rays can be reflected etc.
 - ▶ Can provide connectivity without line of sight
- ▶ A channel can also include multiple “rays” that take different paths
 - ▶ Known as multipath

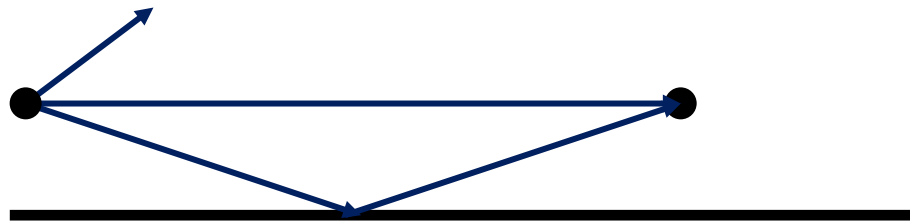

But how can two hosts communicate?

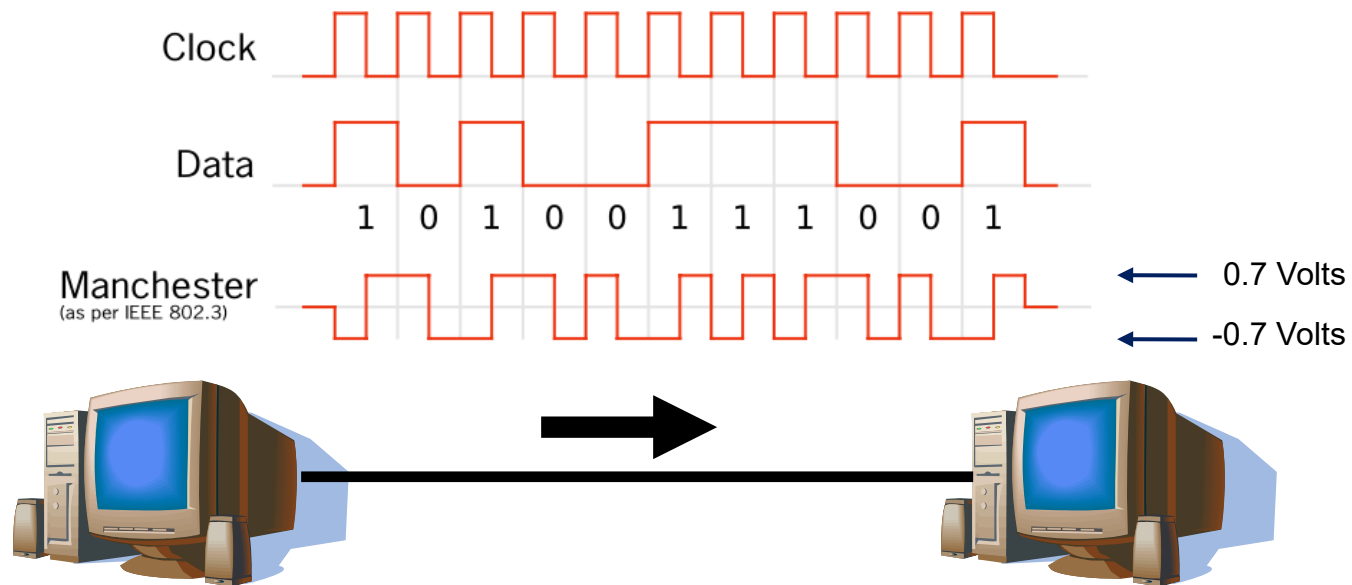

- ▶ Encode information on modulated “Carrier signal”
 - ▶ Phase, frequency, and/or amplitude modulation

Analog vs. Digital Transmission

- ▶ **Analog** and **digital** correspond roughly to **continuous** and **discrete**
- ▶ **Data**: entities that convey meaning
 - ▶ **Analog**: continuously varying patterns of intensity (e.g., voice and video)
 - ▶ **Digital**: discrete values (e.g., integers, ASCII text)
- ▶ **Signals**: electric or electromagnetic encoding of data
 - ▶ **Analog**: continuously varying electromagnetic wave
 - ▶ **Digital**: sequence of voltage pulses



Time Domain View:

Periodic versus Aperiodic Signals

▶ Periodic signal

- ▶ Analog or digital signal pattern that repeats over time

$$s(t + T) = s(t)$$

where T is the period of the signal

- ▶ Allows us to take a frequency view

▶ Aperiodic signal

- ▶ Analog or digital signal pattern that doesn't repeat over time
- ▶ Can “make” an aperiodic signal periodic by taking a slice T and repeating it
- ▶ Often what we do implicitly



Key Parameters of a (Periodic) Signal

- ▶ **Peak amplitude (A)**
 - ▶ Maximum value or strength of the signal over time
 - ▶ Typically measured in volts
- ▶ **Frequency (f)**
 - ▶ Rate, in cycles per second, or Hertz (Hz) at which the signal repeats
- ▶ **Period (T)**
 - ▶ Amount of time it takes for one repetition of the signal
 - ▶ $T = 1/f$
- ▶ **Phase (ϕ)**
 - ▶ Measure of the relative position in time within a single period of a signal
- ▶ **Wavelength (λ)**
 - ▶ Distance occupied by a single cycle of the signal
 - ▶ Or, the distance between two points of corresponding phase of two consecutive cycles



Sine Wave Parameters

- ▶ General sine wave
 - ▶ $s(t) = A \sin(2\pi ft + \phi)$
- ▶ Effect of parameters
 - ▶ $A = 1, f = 1 \text{ Hz},$
 $\phi = 0; \text{ thus } T = 1 \text{ s}$

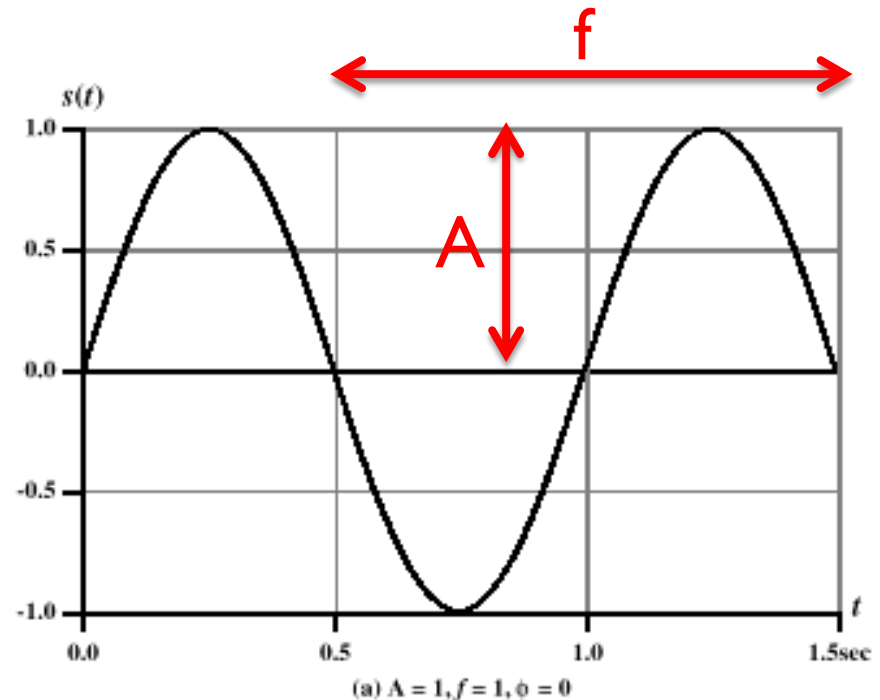

- ▶ note: $2\pi \text{ radians} = 360^\circ = 1 \text{ period}$

Sine Wave Parameters

▶ General sine wave

▶ If x-axis = time

- ▶ y -axis = value of a signal at a given point in *space*

▶ If x-axis = space

- ▶ y -axis = value of a signal at a given point in *time*

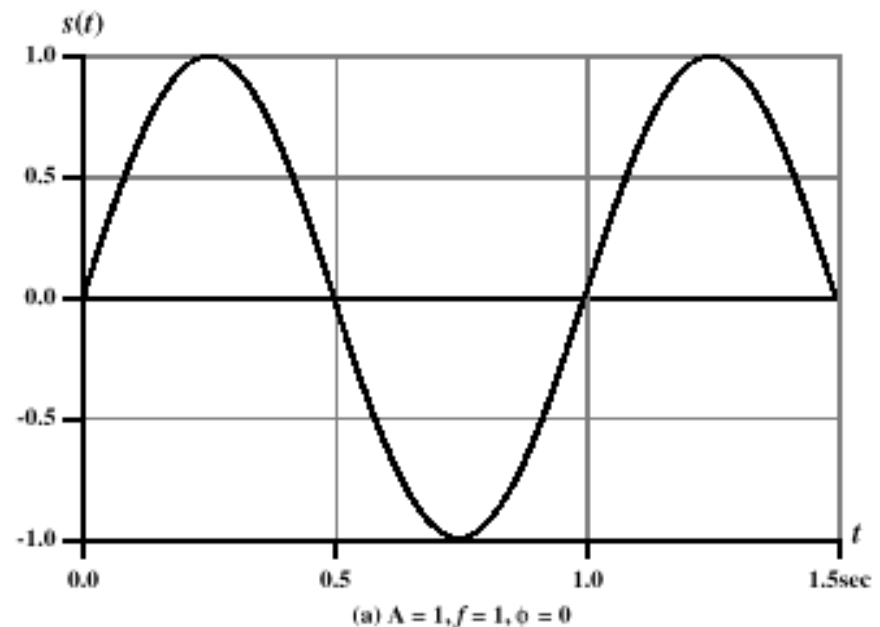

- ▶ note: 2π radians = 360° = 1 period

Sine Wave Parameters

- ▶ **General sine wave**
 - ▶ $s(t) = A \sin(2\pi ft + \phi)$
- ▶ **Effect of parameters**
 - ▶ Reduced peak amplitude; $A=0.5$

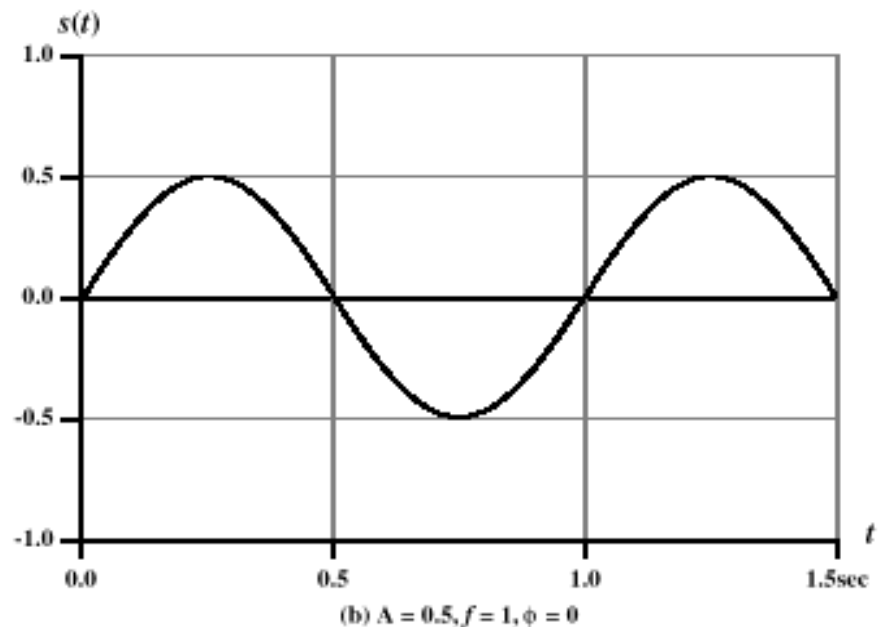

- ▶ note: 2π radians = 360° = 1 period

Sine Wave Parameters

- ▶ General sine wave
 - ▶ $s(t) = A \sin(2\pi ft + \phi)$
- ▶ Effect of parameters
 - ▶ Increased frequency;
 $f = 2$, thus $T = \frac{1}{2}$

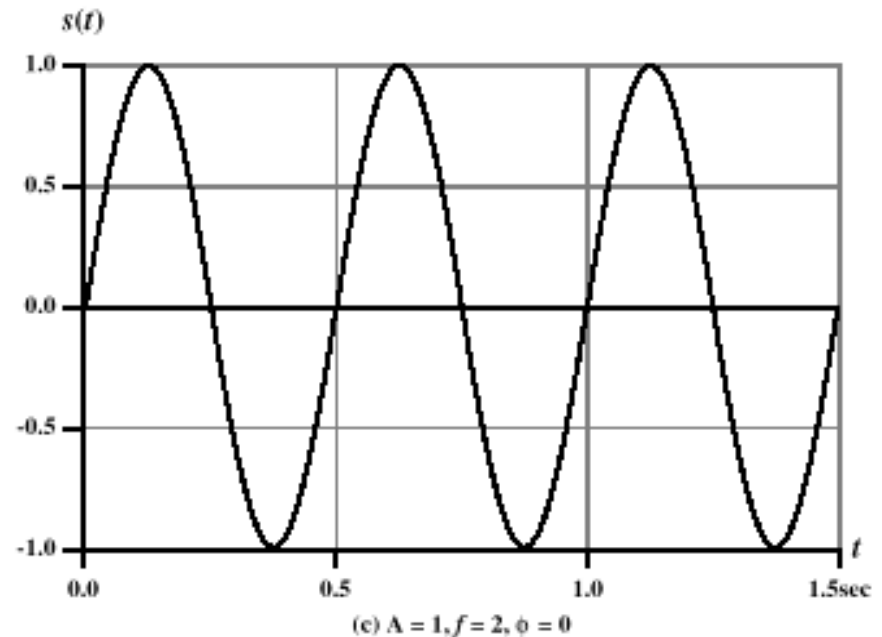

- ▶ note: 2π radians = $360^\circ = 1$ period

Sine Wave Parameters

- ▶ General sine wave
 - ▶ $s(t) = A \sin(2\pi ft + \phi)$
- ▶ Effect of parameters
 - ▶ Phase shift
 - $\phi = \pi/4$ radians
(45 degrees)

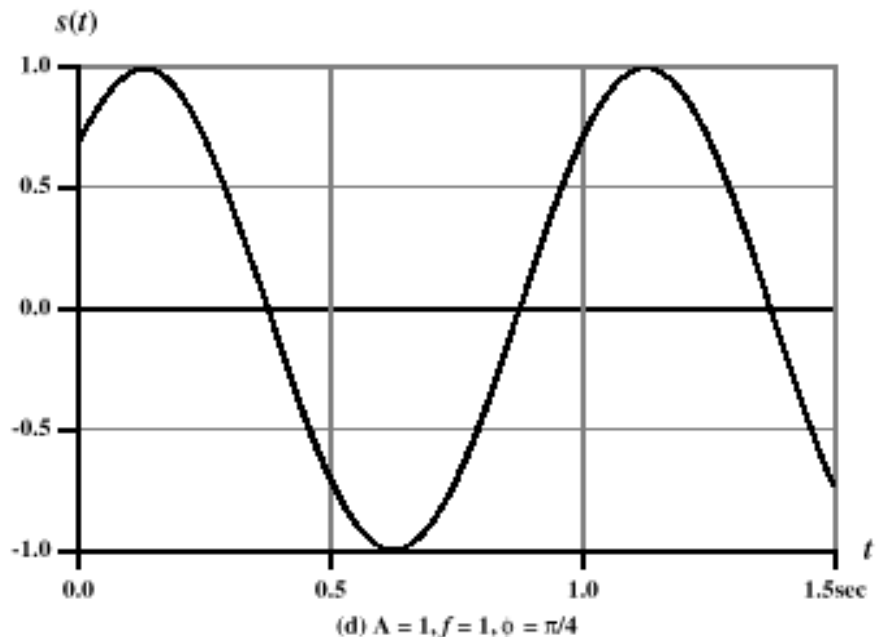

- ▶ note: 2π radians = $360^\circ = 1$ period

Signal Modulation

- ▶ **Amplitude modulation (AM)**
 - ▶ Change the strength of the signal
 - ▶ High values -> stronger signal
- ▶ **Frequency modulation (FM)**
 - ▶ Change the frequency of the signal
- ▶ **Phase modulation (PM)**
 - ▶ Change the phase of the signal

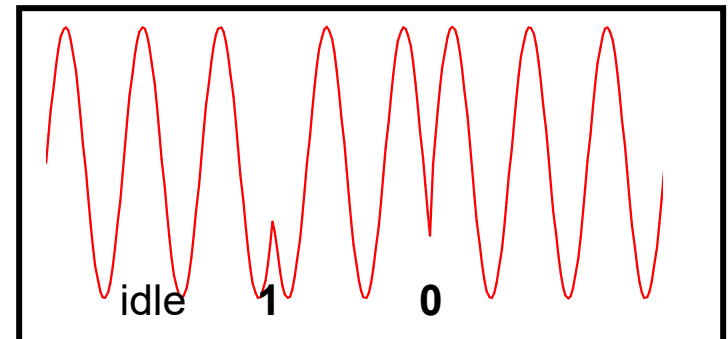
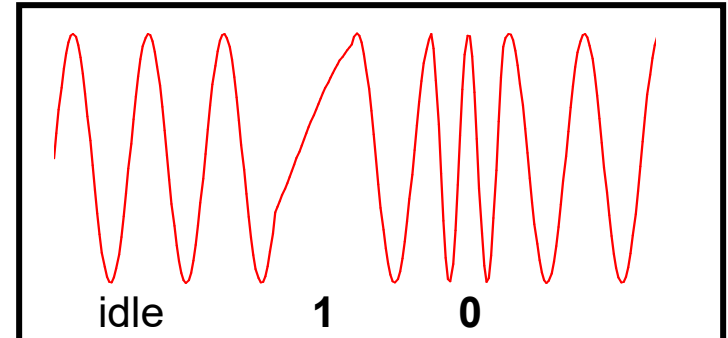
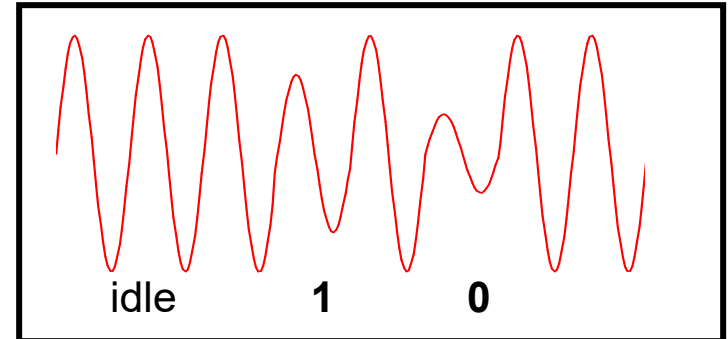

Frequency-Domain Concepts

- ▶ **Electromagnetic signal**
 - ▶ A collection of periodic analog signals (sine waves) at different amplitudes, frequencies, and phases
- ▶ **The period of the total signal is equal to the period of the fundamental frequency**
 - ▶ All other frequencies are an integer multiple of the fundamental frequency
- ▶ **Strong relationship between the “shape” of the signal in the time and frequency domain**



Frequency-Domain Concepts

- ▶ A (periodic) signal
 - ▶ A sum of sine waves of different strengths
 - ▶ Example: f and $3f$
 - ▶ Note that $3f$ is an integer multiple of f
- ▶ Fundamental frequency
 - ▶ All frequency components are integer multiples of one frequency

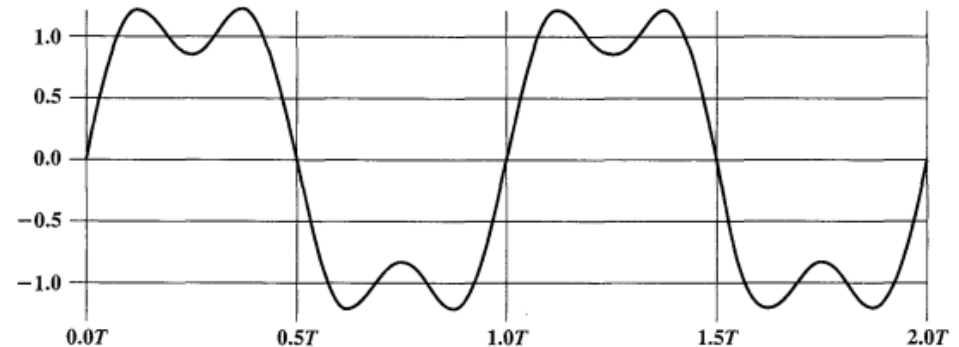

$$(4/\pi)[\sin 2\pi ft] + (1/3)\sin(2\pi 3ft)$$



Frequency-Domain Concepts

- ▶ A (periodic) signal
 - ▶ A sum of sine waves of different strengths
 - ▶ Example: f and $3f$
 - ▶ Note that $3f$ is an integer multiple of f
- ▶ Fundamental frequency
 - ▶ Period of the signal = the period of the fundamental frequency

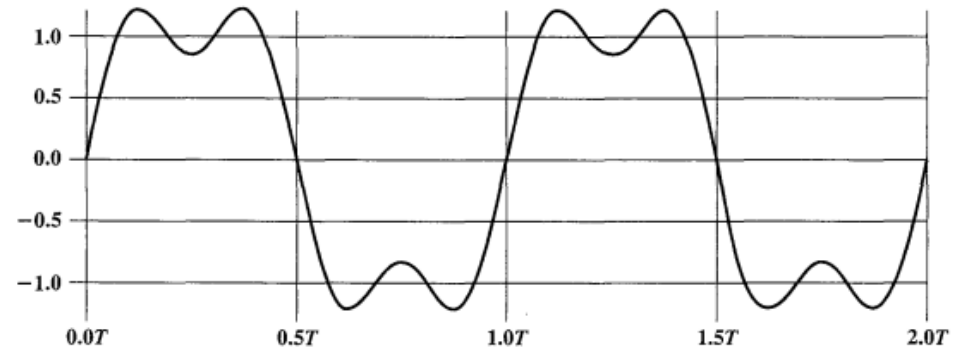

$$(4/\pi)[\sin 2\pi ft] + (1/3)\sin(2\pi 3ft)$$



Frequency-Domain Concepts

- ▶ **Spectrum**

- ▶ Range of frequencies
- ▶ From f to $3f$

- ▶ **Absolute bandwidth**

- ▶ Width of the spectrum
- ▶ $3f - f = 2f$

- ▶ **Effective bandwidth**

- ▶ Narrow band of frequencies that most of the signal's energy is contained in

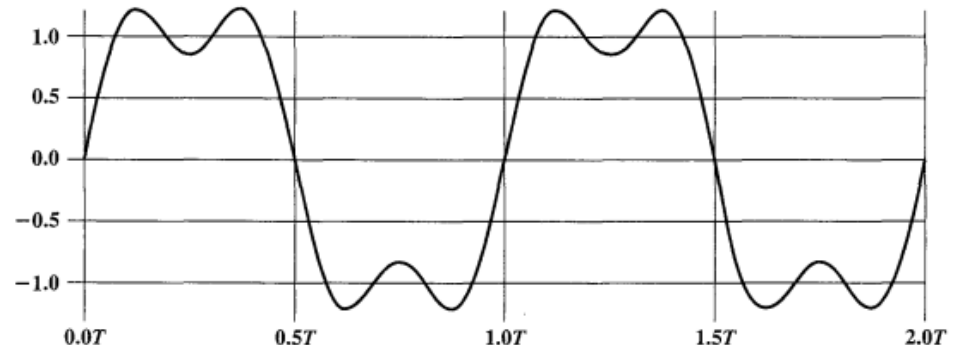

$$(4/\pi)[\sin 2\pi ft] + (1/3)\sin(2\pi 3ft)$$



Relationship between Data Rate and Bandwidth

- ▶ **Bandwidth translates to bits**
 - ▶ The greater the (spectral) bandwidth, the higher the information-carrying capacity of the signal (data bandwidth)
 - ▶ Intuition: if a signal can change faster, it can be modulated in a more detailed way and can carry more data
- ▶ **Extreme example**
 - ▶ A signal that only changes once a second will not be able to carry a lot of bits or convey a very interesting TV channel



Signals to bits

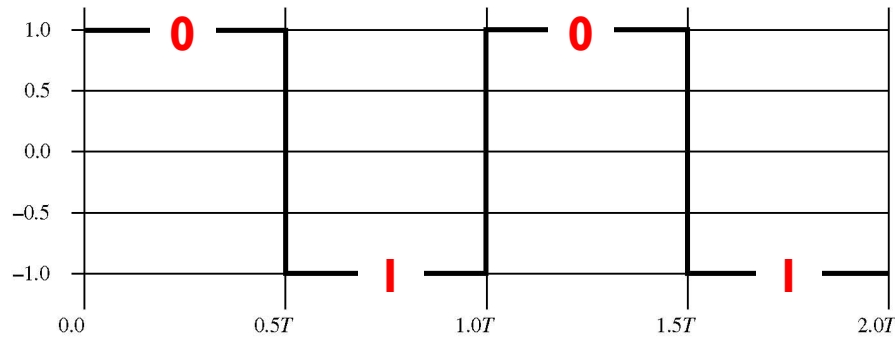

- ▶ Each pulse lasts $1/2f$
- ▶ Data rate = $2f$ bps

Signals to bits

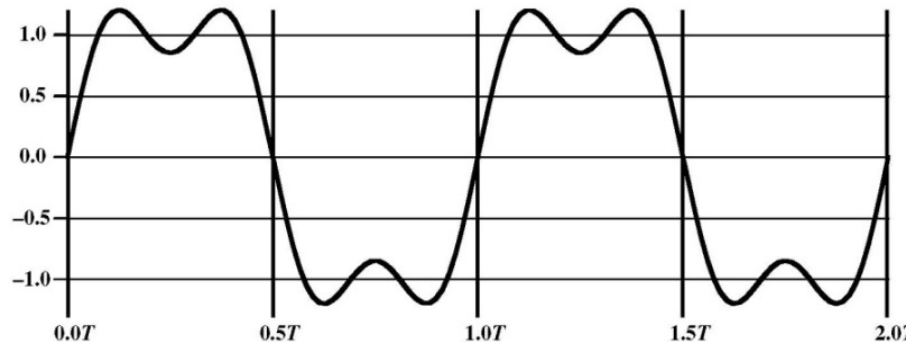
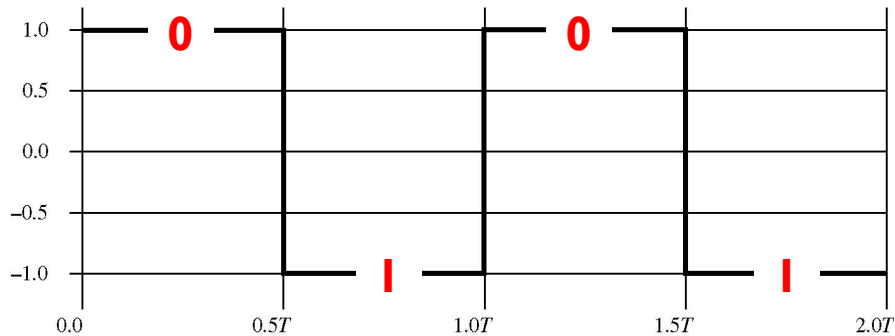

▶ Each pulse lasts $1/2f$

▶ Data rate = $2f$ bps

▶ Add two sine waves

$$(4/\pi)[\sin 2\pi ft] + (1/3)\sin(2\pi 3ft)]$$



Signals to bits

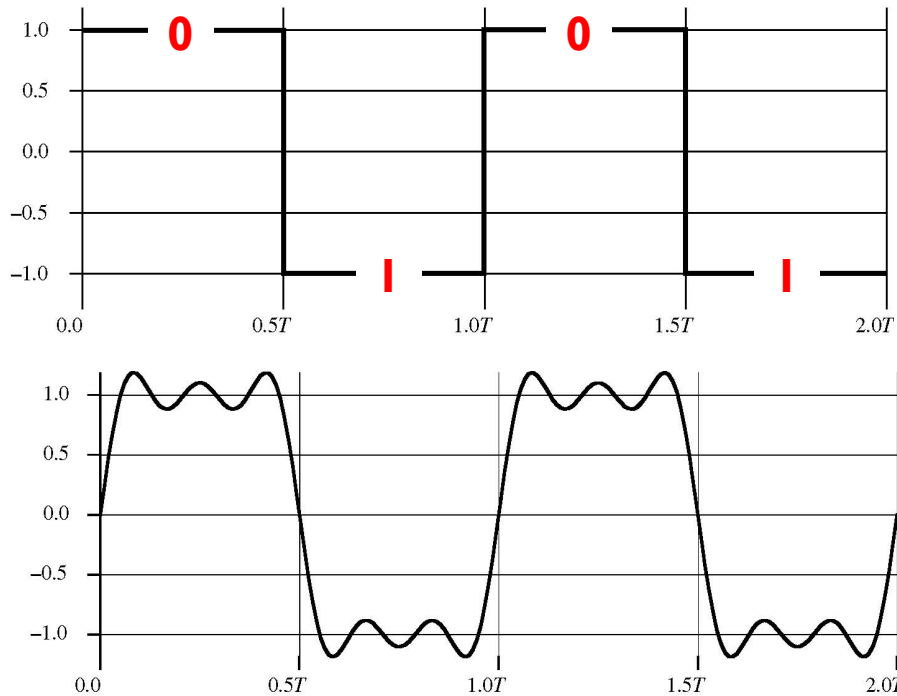

▶ Each pulse lasts $1/2f$

▶ Data rate = $2f$ bps

▶ Add a sine wave with frequency $5f$

Signals to bits

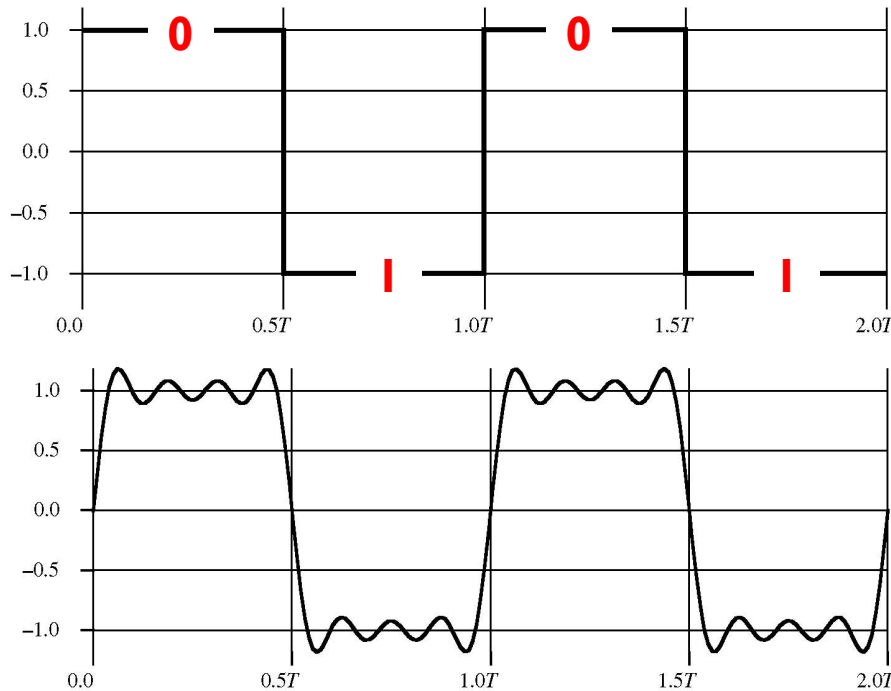

▶ Each pulse lasts $1/2f$

▶ Data rate = $2f$ bps

▶ Add a sine wave with frequency $7f$

▶ And so on ...

Infinite frequencies = infinite bandwidth!

not quite ...

Data rate

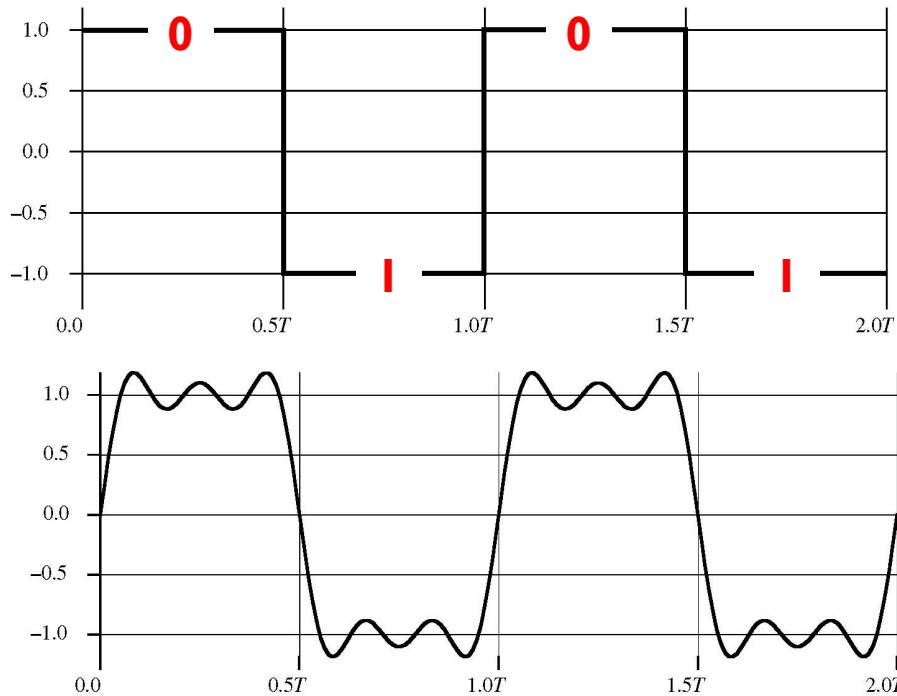

Close enough to square wave to distinguish 0 and 1

- ▶ Available bandwidth of bandwidth of 4MHz
- ▶ If $f = 10^6$ cycles/sec = 1MHz
 - ▶ Signal bandwidth = 4MHz
 - ▶ $T = 1$ bit/0.5 μ sec
 - ▶ Data rate = 2 Mbps

Data rate

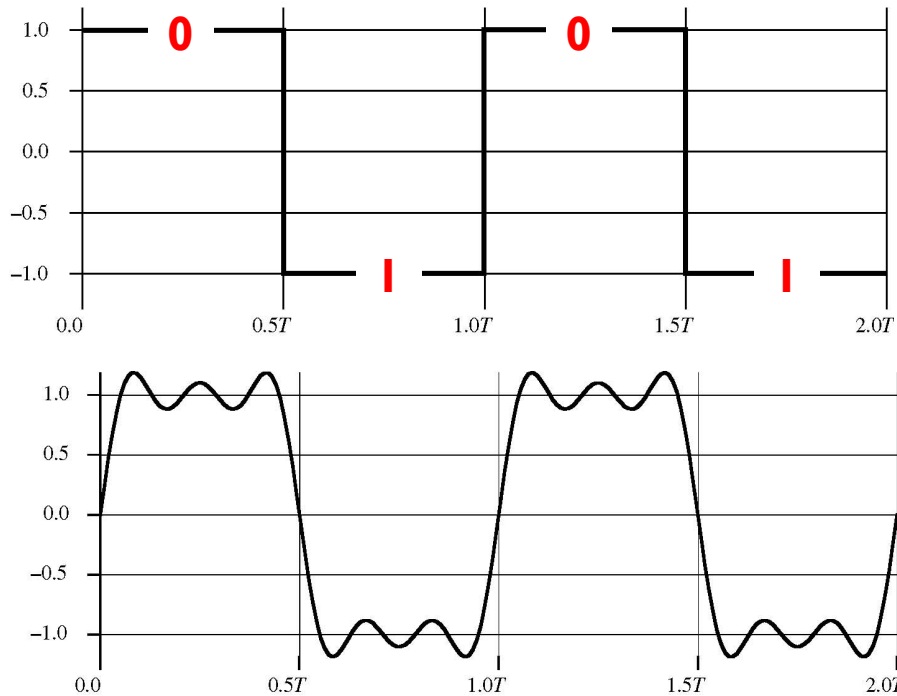

Close enough to square wave to distinguish 0 and 1

▶ Available bandwidth of bandwidth of 8MHz

▶ If $f = 2\text{MHz}$

- ▶ Signal bandwidth = 8MHz
- ▶ $T = 1 \text{ bit}/0.25 \mu\text{sec}$
- ▶ Data rate = 4 Mbps

2X BW = 2X data rate

Data rate

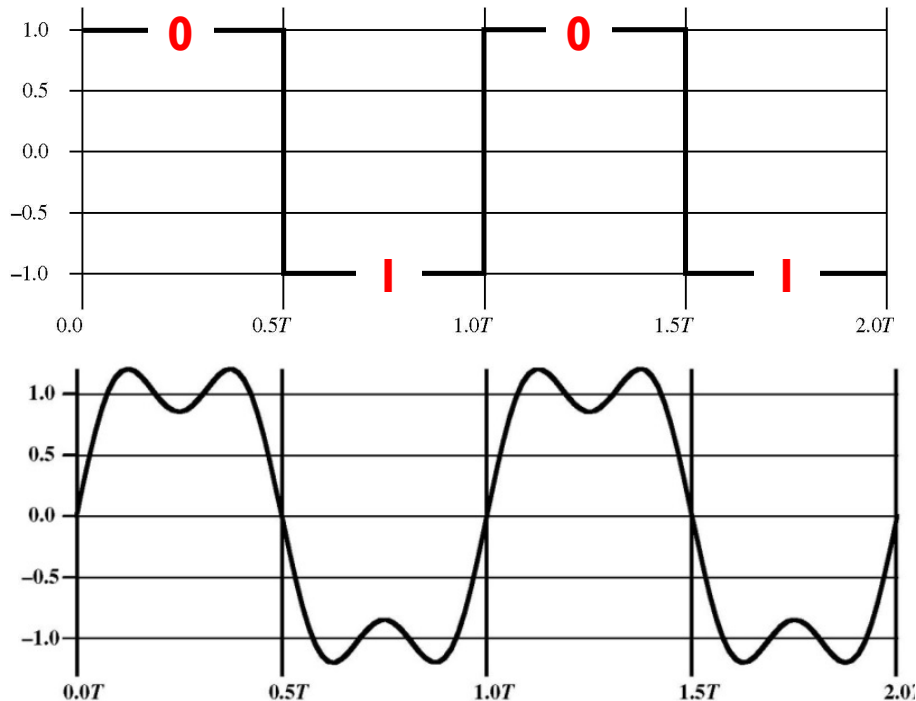

What if this is good enough?

- ▶ Available bandwidth of bandwidth of 4MHz
- ▶ If $f = 2\text{MHz}$
 - ▶ Signal bandwidth = 4MHz
 - ▶ $T = 1 \text{ bit}/0.25 \mu\text{sec}$
 - ▶ Data rate = 4 Mbps

IF the receiver can distinguish between 0 and 1!

Signals: Back to Analog and Digital

▶ Goal

- ▶ Sender changes the signal, e.g. the amplitude, in a way that the receiver can recognize

▶ Analog: a continuously varying electromagnetic wave that may be propagated over a variety of media, depending on frequency

- ▶ Wired: Twisted pair, coaxial cable, fiber
- ▶ Wireless: Atmosphere or space propagation
- ▶ Cannot recover from distortions, noise

▶ Digital: discrete changes in the signal that correspond to a digital signal

- ▶ Less susceptible to noise but can suffer from attenuation
- ▶ Can regenerate signal along the path (repeater versus amplifier)

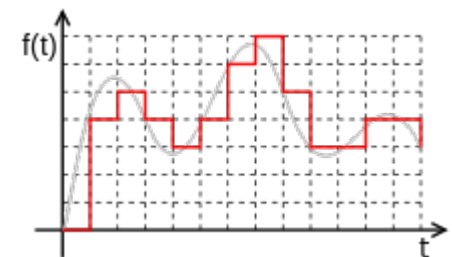
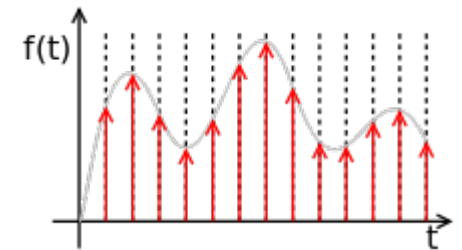

Channel Capacity

- ▶ **Data rate**
 - ▶ Rate at which data can be communicated (bps)
- ▶ **Channel Capacity**
 - ▶ Maximum rate at which data can be transmitted over a given channel, under given conditions
- ▶ **Bandwidth**
 - ▶ Bandwidth of the transmitted signal as constrained by the transmitter and the nature of the transmission medium (Hertz)
- ▶ **Noise**
 - ▶ Average level of noise over the communications path
- ▶ **Error rate**
 - ▶ Rate at which errors occur
 - ▶ Error = transmit 1 and receive 0; transmit 0 and receive 1



Sampling

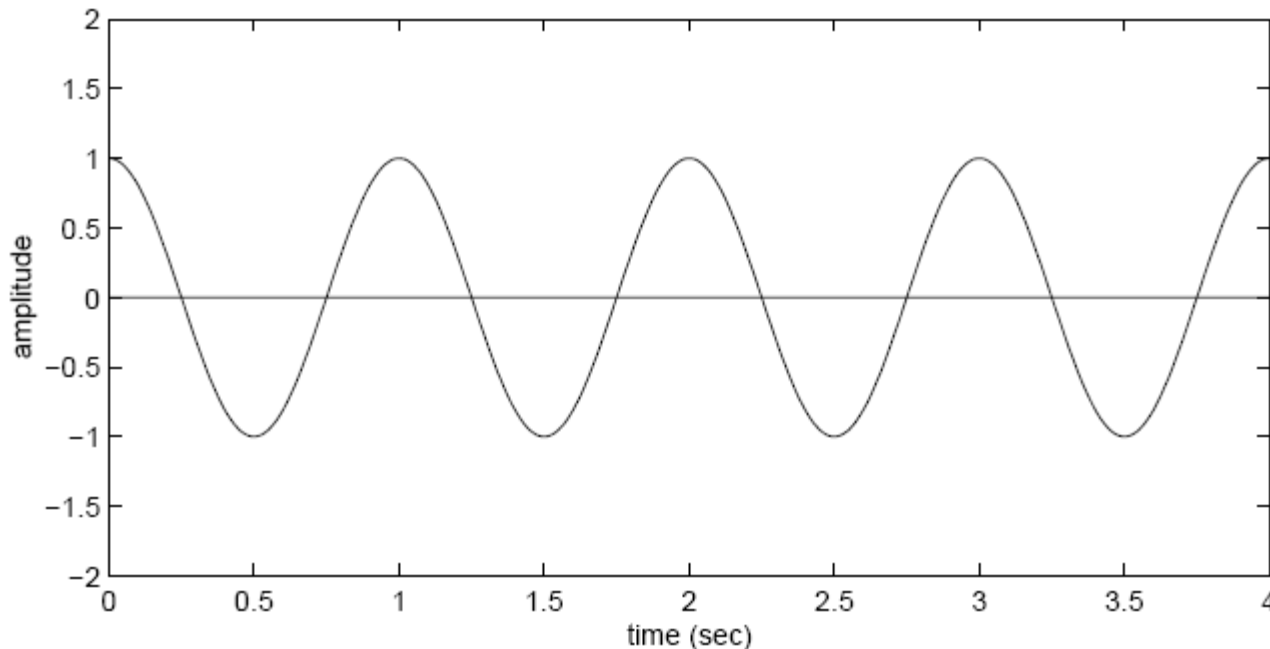

- ▶ Suppose you have the following 1 Hz signal being received
- ▶ How fast do you need to sample, to capture the signal?

Sampling

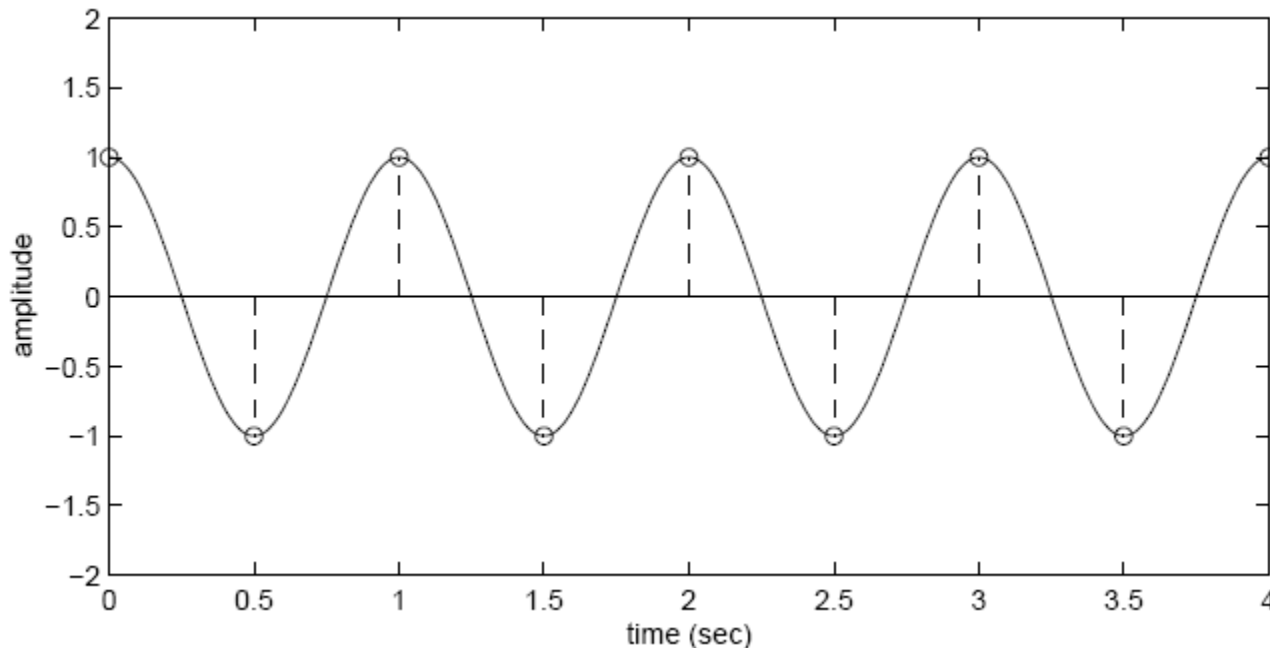

- ▶ Sampling a 1 Hz signal at 2 Hz is enough
 - ▶ Captures every peak and trough



Sampling

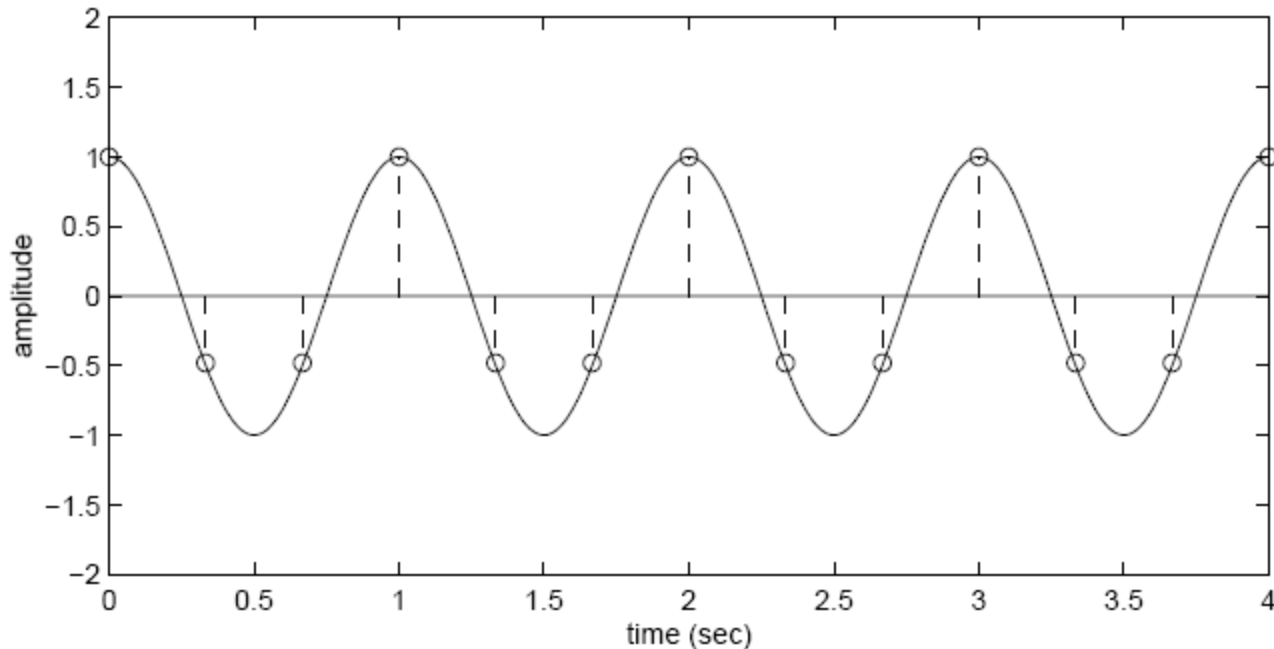

- ▶ Sampling a 1 Hz signal at 3 Hz is also enough
 - ▶ In fact, more than enough samples to capture variation in signal

Sampling

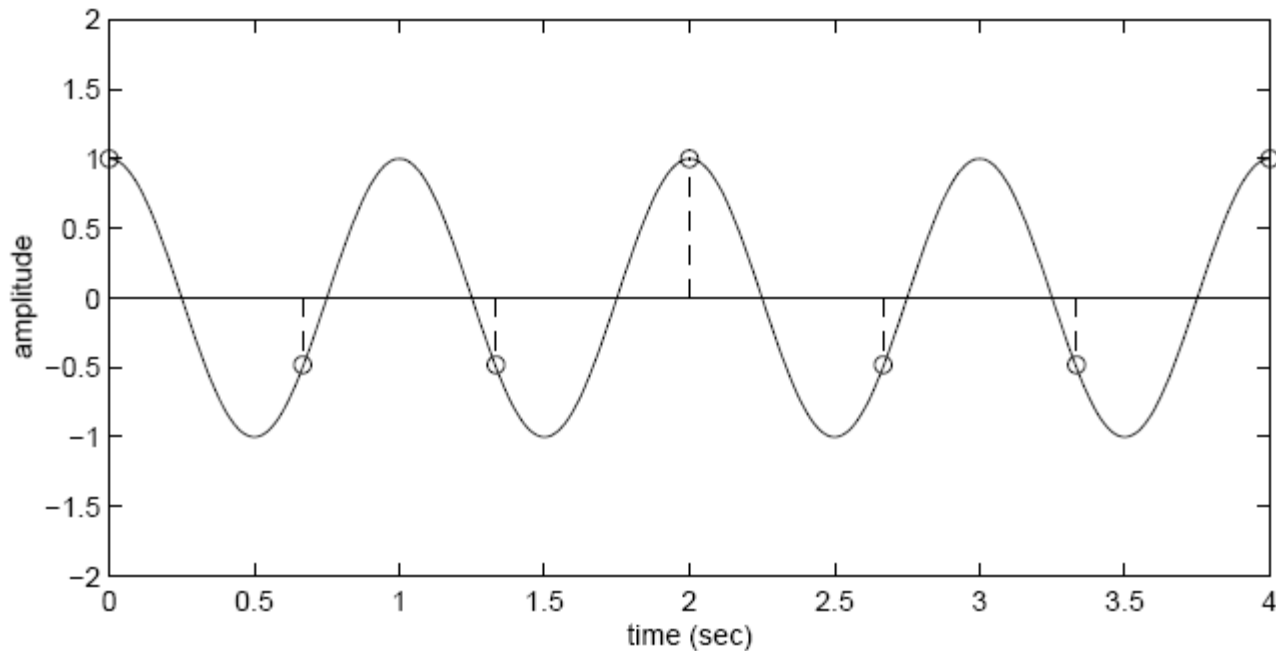

- ▶ Sampling a 1 Hz signal at 1.5 Hz is not enough
 - ▶ Why?

Sampling

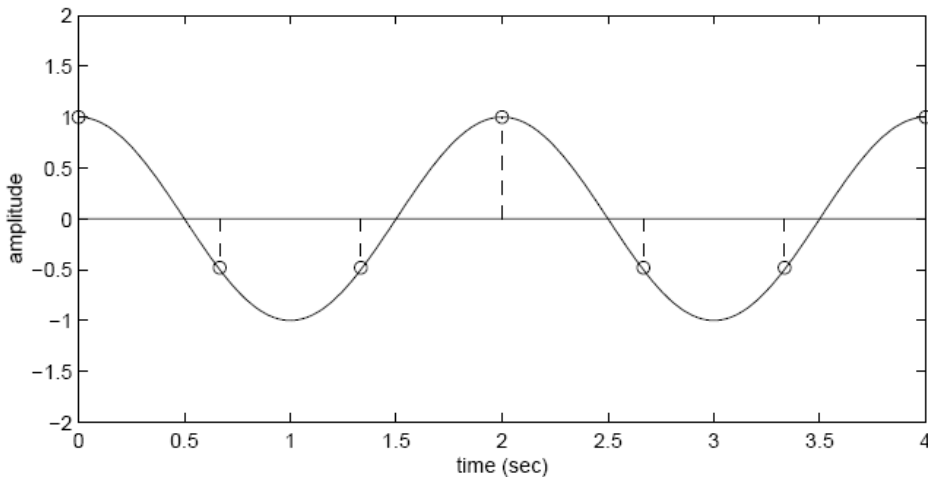
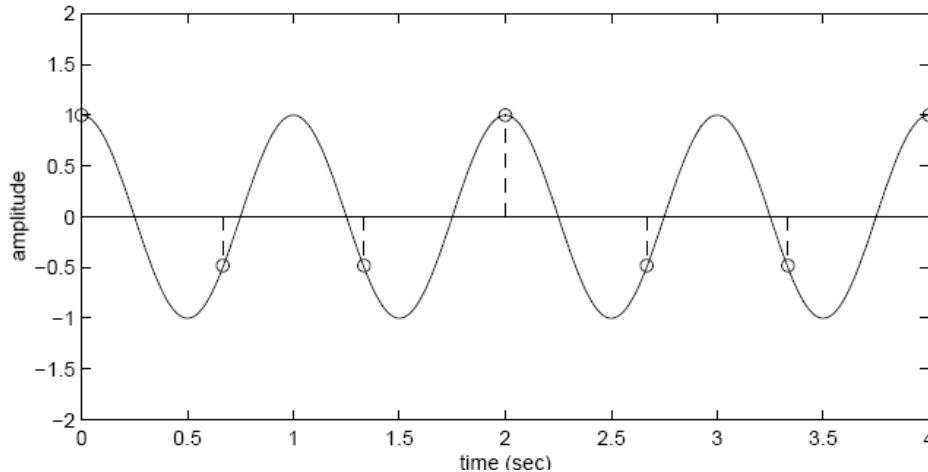

- ▶ Sampling a 1 Hz signal at 1.5 Hz is not enough
 - ▶ Can't distinguish between multiple possible signals
 - ▶ Problem known as **aliasing**

Aliasing



What about more complex signals?

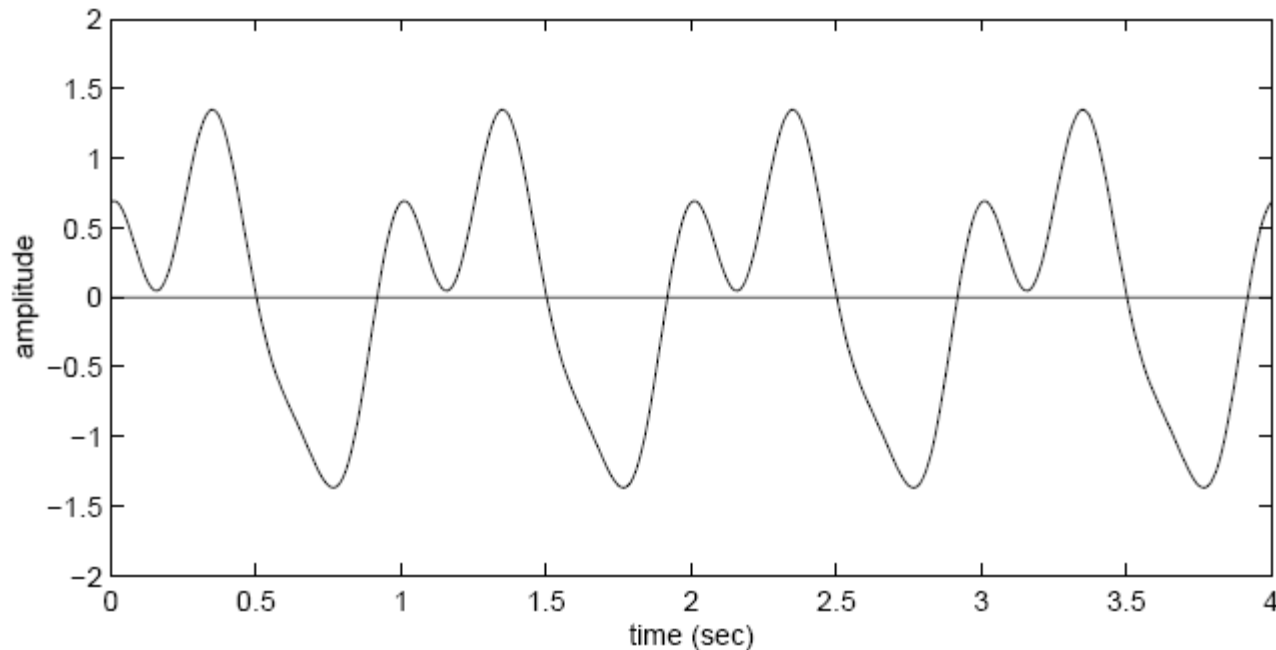

- ▶ Fourier's theorem
 - ▶ Any continuous signal can be decomposed into a sum of sines and cosines at different frequencies
 - ▶ Example: Sum of 1 Hz, 2 Hz, and 3 Hz sines
 - ▶ **How fast to sample?**



What about more complex signals?

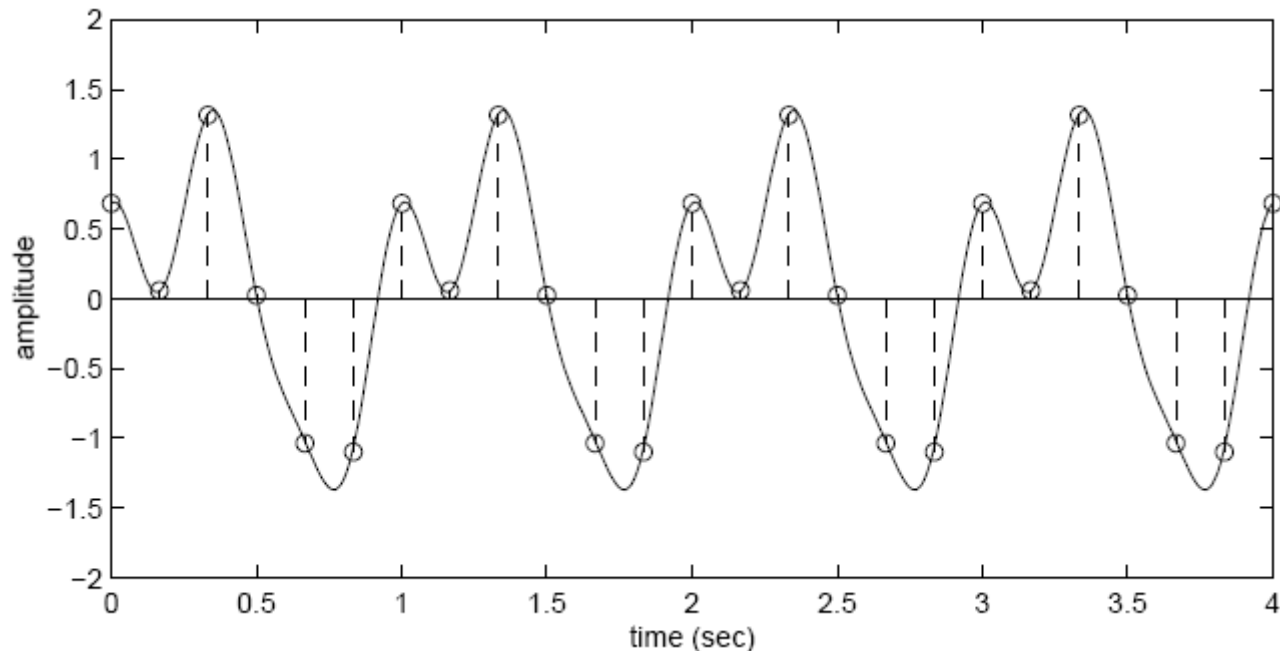

- ▶ Fourier's theorem
 - ▶ Any continuous signal can be decomposed into a sum of sines and cosines at different frequencies
- ▶ Example: Sum of 1 Hz, 2 Hz, and 3 Hz sines
 - ▶ How fast to sample? --> **answer: 6 Hz**

Generalizing the Examples

- ▶ What data rate can a channel sustain?
- ▶ How is data rate related to bandwidth?
- ▶ How does noise affect these bounds?
- ▶ What else can limit maximum data rate?



What Data Rate can a Channel Sustain?

How is Data Rate Related to Bandwidth?

- ▶ Transmitting N distinct signals over a noiseless channel with bandwidth B , we can achieve at most a data rate of



- ▶ ex.: a 3000 Hz channel can transmit data at a rate of at most 6000 bits/second

- ▶ Nyquist's Sampling Theorem (H. Nyquist, 1920's)

What Data Rate can a Channel Sustain?

How is Data Rate Related to Bandwidth?

- ▶ Transmitting **N** distinct signals over a noiseless channel with bandwidth **B**, we can achieve at most a data rate of



Baud rate

- ▶ ex.: a 3000 baud rate of at most 6000 bits/second

Number of **physical symbols** transmitted per second

rate of at most

Bit rate

Actual number of **data bits** transmitted per second

- ▶ Nyquist's Relationship

Depends on the number of **bits** encoded in each **symbol**

(20's)



Noiseless Capacity

- ▶ Nyquist's theorem: $2B \log_2 N$
- ▶ Example 1: sampling rate of a phone line
 - ▶ $B = 4000$ Hz
 - ▶ $2B = 8000$ samples/sec.
 - ▶ sample every 125 microseconds



Noiseless Capacity

- ▶ Nyquist's theorem: $2B \log_2 N$
- ▶ Example 2: noiseless capacity
 - ▶ $B = 1200$ Hz
 - ▶ $N =$ each pulse encodes 16 symbols
 - ▶ $C = 2B \log_2 (N) = D \times \log_2 (N)$
 $= 2400 \times 4 = 9600$ bps



How does Noise affect these Bounds?

▶ Noise

- ▶ Blurs the symbols, reducing the number of symbols that can be reliably distinguished

▶ Claude Shannon (1948)

- ▶ Extended Nyquist's work to channels with additive white Gaussian noise (a good model for thermal noise)

$$\text{channel capacity } C = B \log_2 (1 + S/N)$$

where

C is the maximum supportable bit rate

B is the channel bandwidth

S/N is the ratio between signal power
and in-band noise power

↖
N is noise

How does Noise affect these Bounds?

- ▶ **Noise**

- ▶ Blurs the symbols, reducing the number of symbols that can be reliably distinguished

- ▶ **Claude Shannon (1948)**

- ▶ Extended Nyquist's work to channels with additive white Gaussian noise (a good model for thermal noise)

$$\text{channel capacity } C = B \log_2 (1 + S/N)$$

- ▶ **Represents error free capacity**

- ▶ also used to calculate the noise that can be tolerated to achieve a certain rate through a channel

- ▶ **Result is based on many assumptions**

- ▶ Formula assumes white noise (thermal noise)
- ▶ Impulse noise is not accounted for
- ▶ Various types of distortion are also not accounted for



Noisy Capacity

- ▶ Telephone channel

- ▶ 3400 Hz at 40 dB SNR

$$\text{SNR(dB)} = 10 \log_{10} \left(\frac{P_{\text{signal}}}{P_{\text{noise}}} \right)$$

decibels (dB) is a **logarithmic** unit of measurement that expresses the magnitude of a physical quantity (usually power or intensity) relative to a specified or implied reference level



Decibels

- ▶ A ratio between signal powers is expressed in decibels

$$\text{decibels (db)} = 10\log_{10}(P_1 / P_2)$$

- ▶ Used in many contexts
 - ▶ The loss of a wireless channel
 - ▶ The gain of an amplifier
- ▶ Note that dB is a relative value
 - ▶ Can be made absolute by picking a reference point
 - ▶ Decibel-Watt – power relative to 1W
 - ▶ Decibel-milliwatt – power relative to 1 milliwatt



Signal-to-Noise Ratio

- ▶ **Signal-to-noise ratio (SNR, or S/N)**

- ▶ Ratio of

- ▶ the power in a signal
to

- ▶ the power contained in the noise

$$(SNR)_{\text{dB}} = 10 \log_{10} \frac{\text{signal power}}{\text{noise power}}$$

- ▶ Typically measured at a receiver

- ▶ **A high SNR**

- ▶ High-quality signal

- ▶ **Low SNR**

- ▶ May be hard to “extract” the signal from the noise

- ▶ **SNR sets upper bound on achievable data rate**



Noisy Capacity

▶ Telephone channel

▶ 3400 Hz at 40 dB SNR

▶ $C = B \log_2 (1+S/N)$ bits/s

▶ SNR = 40 dB

$$40 = 10 \log_{10} (S/N)$$

$$S/N = 10,000$$

▶ $C = 3400 \log_2 (10001) = 44.8$ kbps

$$\text{SNR(dB)} = 10 \log_{10} \left(\frac{P_{\text{signal}}}{P_{\text{noise}}} \right)$$



Shannon Discussion

- ▶ Bandwidth B and noise N are not independent
 - ▶ N is the noise in the signal band, so it increases with the bandwidth
- ▶ Shannon does not provide the coding that will meet the limit, but the formula is still useful



Multiplexing

- ▶ **Capacity of transmission medium**
 - ▶ May exceed capacity required for transmission of a single signal
- ▶ **Multiplexing**
 - ▶ Carrying multiple signals on a single medium
 - ▶ More efficient use of transmission medium



Multiplexing

- ▶ **FDM: Frequency Division Multiplexing**
 - ▶ Channel spectrum divided into frequency bands
 - ▶ Each assigned fixed frequency band/reduced rate
 - ▶ Unused transmission time in frequency bands go idle
 - ▶ Example: 6-station LAN, 1,3,4 transmit, frequency bands 2,5,6 idle

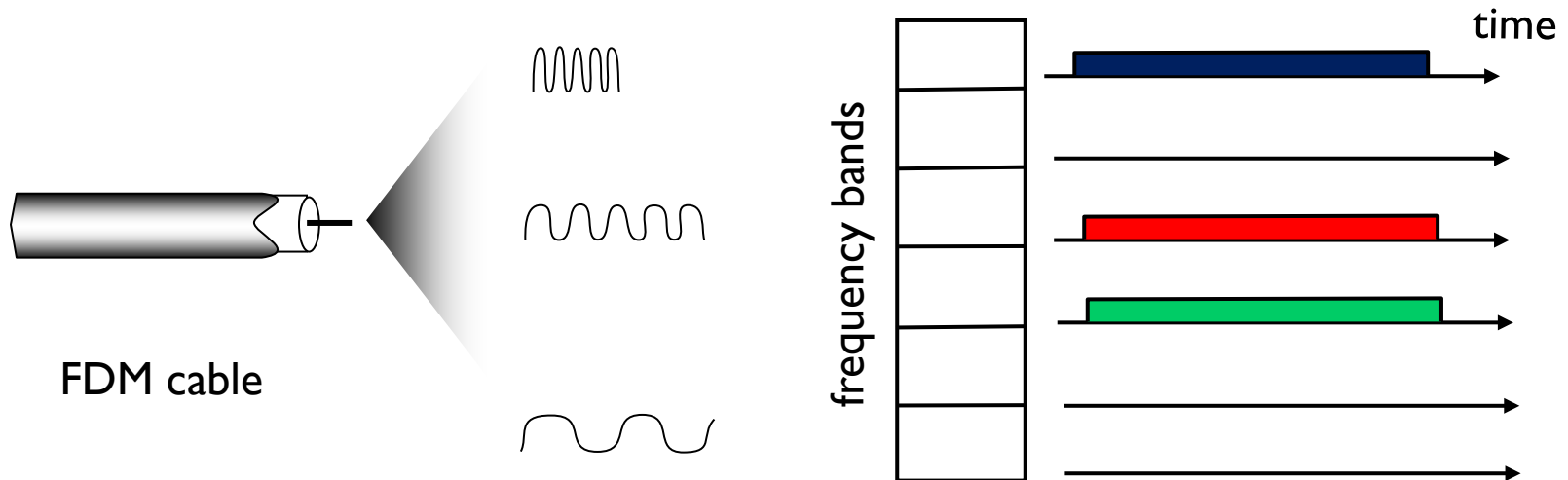

Multiplexing

- ▶ TDM: Time Division Multiplexing
 - ▶ Access in "rounds"
 - ▶ Each user/node/etc... gets fixed length slot in each round
 - ▶ Each user can sent at full speed some of the time
 - ▶ Unused slots go idle
 - ▶ Example: 6-slots with transmissions in slots 0, 3, and 4

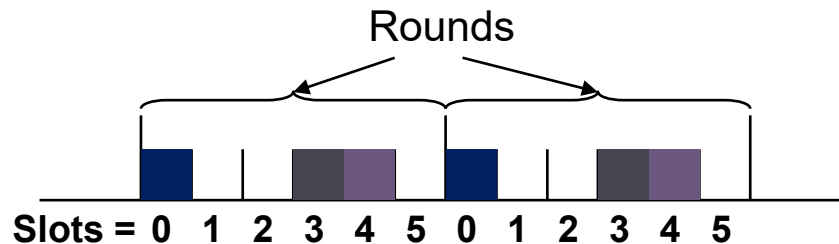

FDM Example: AMPS

- ▶ US analog cellular system in early 80's
- ▶ Each call uses an up and down link channel
 - ▶ Channels are 30 KHz
- ▶ About 12.5 + 12.5 MHz available for up and down link channels per operator
 - ▶ Supports 416 channels in each direction
 - ▶ 21 of the channels are used for data/control
 - ▶ Total capacity (across operators) is double of this



TDM Example: GSM

- ▶ **Global System for Mobile communication**
 - ▶ First introduced in Europe in early 90s
- ▶ **Uses a combination of TDM and FDM**
- ▶ **25 MHz each for up and down links.**
- ▶ **Broken up in 200 KHz channels**
 - ▶ 125 channels in each direction
 - ▶ Each channel can carry about 270 kbs
- ▶ **Each channel is broken up in 8 time slots**
 - ▶ Slots are 0.577 msec long
 - ▶ Results in 1000 channels, each with about 25 kbs of useful data; can be used for voice, data, control
- ▶ **General Packet Radio Service (GPRS)**
 - ▶ Data service for GSM, e.g. 4 down and 1 up channel



Frequency Reuse in Space

- ▶ Frequencies can be reused in space
 - ▶ Distance must be large enough
 - ▶ Example: radio stations
- ▶ Basis for “cellular” network architecture
- ▶ Set of “base stations” connected to the wired network support set of nearby clients
 - ▶ Star topology in each circle
 - ▶ Cell phones, 802.11, ...

