

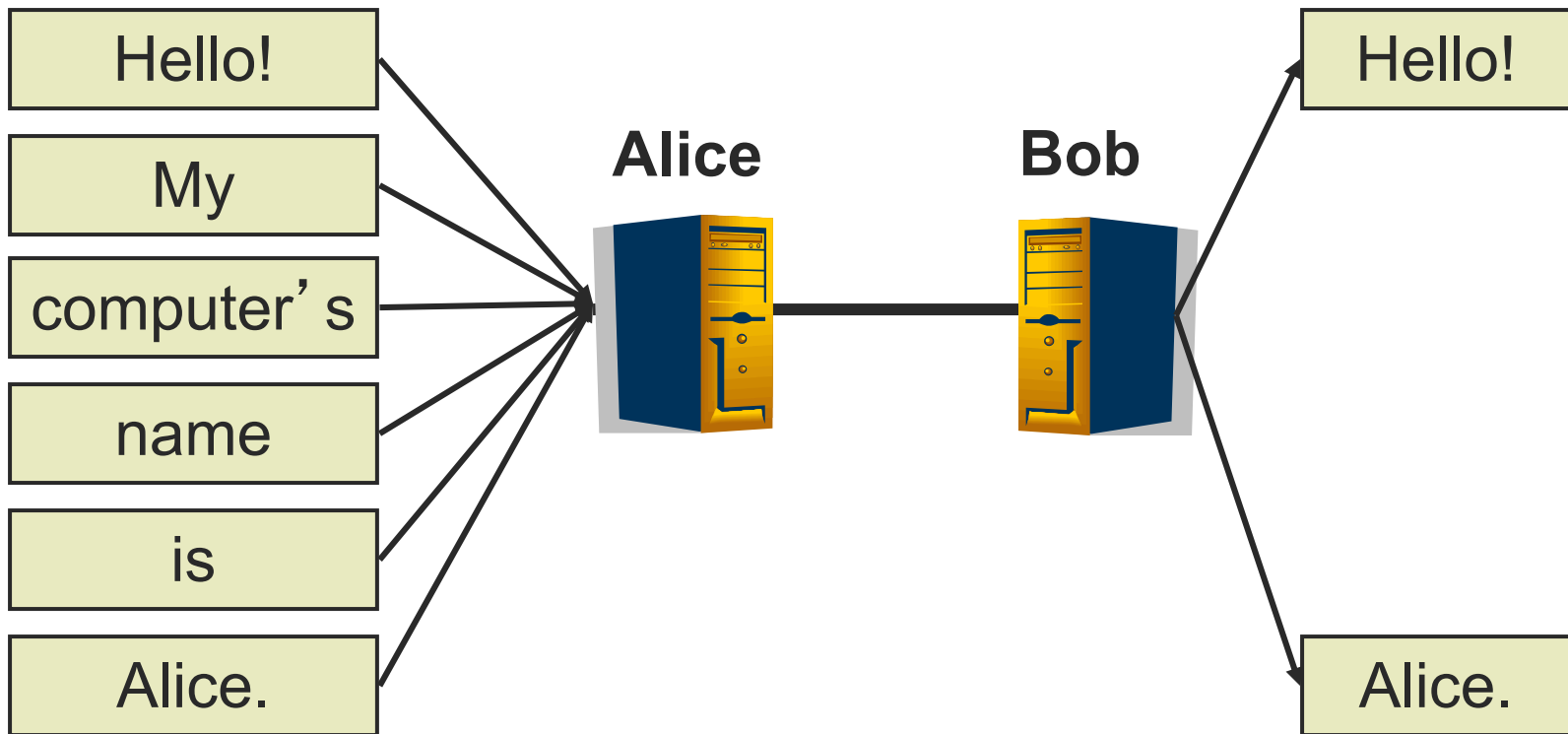

Reliable Transmission

[Reliable Transmission]



[Reliable Transmission]

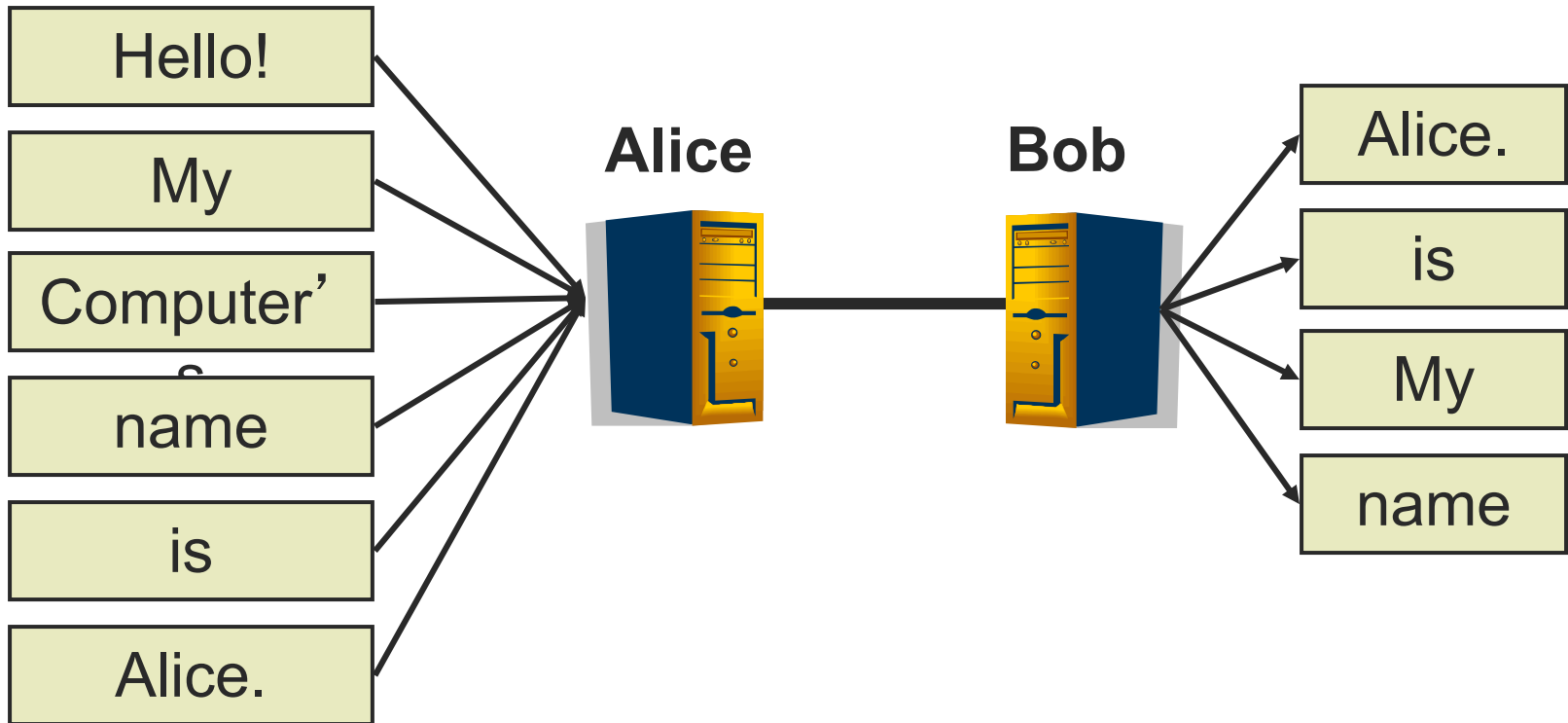

[Reliable Transmission]

- Suppose error protection identifies valid and invalid packets
 - How?
- Can we make the channel appear reliable?
 - Insure packet delivery
 - Maintain packet order
 - Provide reliability at full link capacity



Reliable Transmission Outline

- Fundamentals of Automatic Repeat reQuest (**ARQ**) algorithms
 - A family of algorithms that provide reliability through retransmission
- ARQ algorithms (simple to complex)
 - stop-and-wait
 - concurrent logical channels
 - sliding window
 - go-back-n
 - selective repeat
- Alternative: forward error correction (**FEC**)



[Terminology]

- Acknowledgement (**ACK**)
 - Receiver tells the sender when a frame is received
 - Selective acknowledgement (**SACK**)
 - Specifies set of frames received
 - Cumulative acknowledgement (**ACK**)
 - Have received specified frame and all previous
 - Negative acknowledgement (**NAK**)
 - Receiver refuses to accept frame now, *e.g.*, when out of buffer space



[Terminology]

- Timeout (**TO**)
 - Sender decides the frame (or ACK) was lost
 - Sender can try again



[Stop-and-Wait]

- Basic idea
 1. Send a frame
 2. Wait for an ACK or TO
 3. If TO, go to 1
 4. If ACK, get new frame, go to 1



Stop-and-Wait: Success

How long should the timeout be?

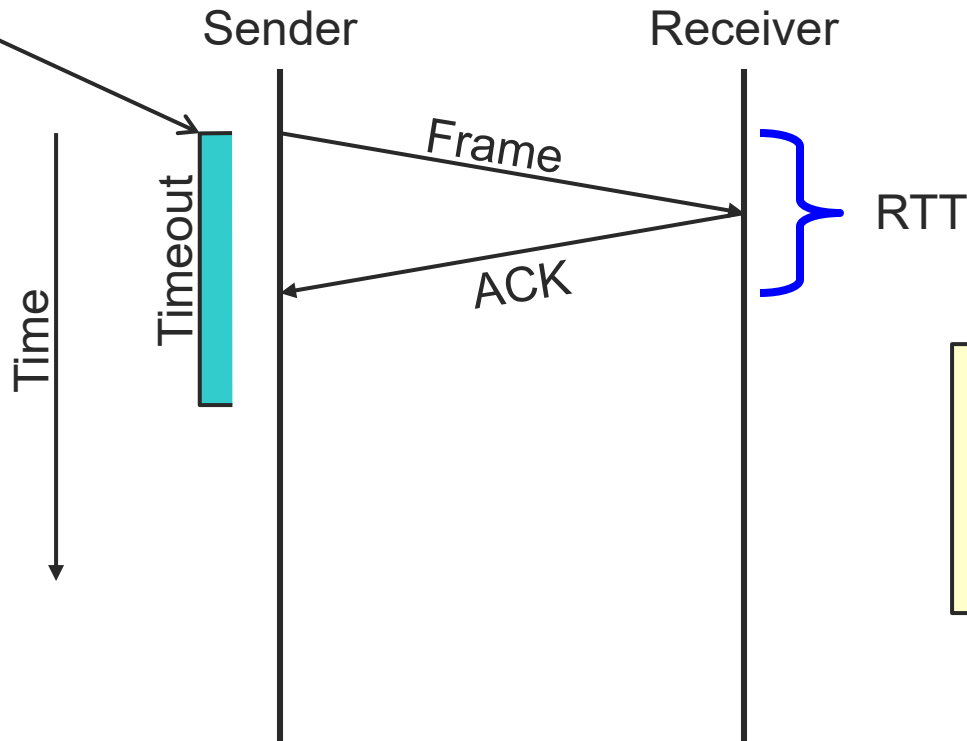

What can go wrong?
How will it affect our protocol?



Stop-and-Wait: Lost Frame

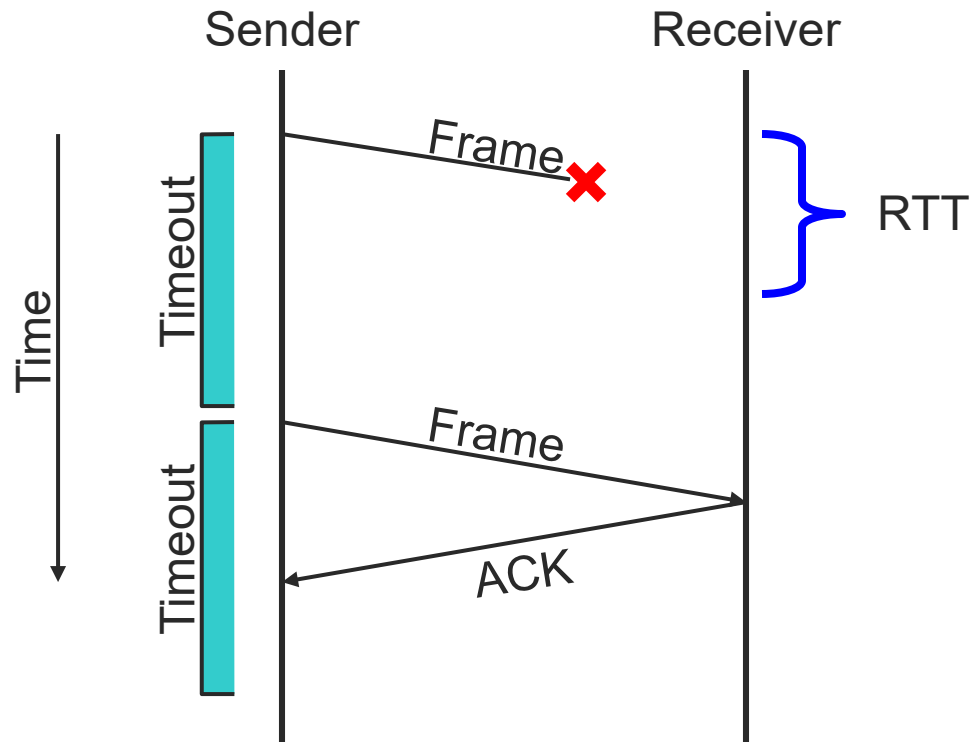

Stop-and-Wait: Lost ACK

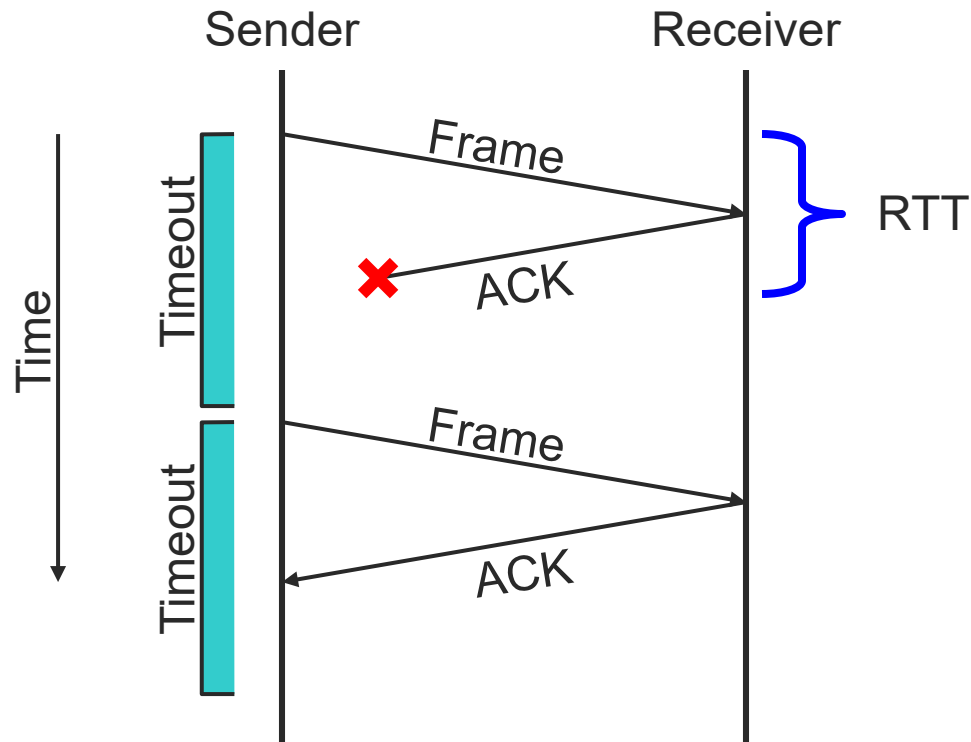

Stop-and-Wait: Delayed Frame

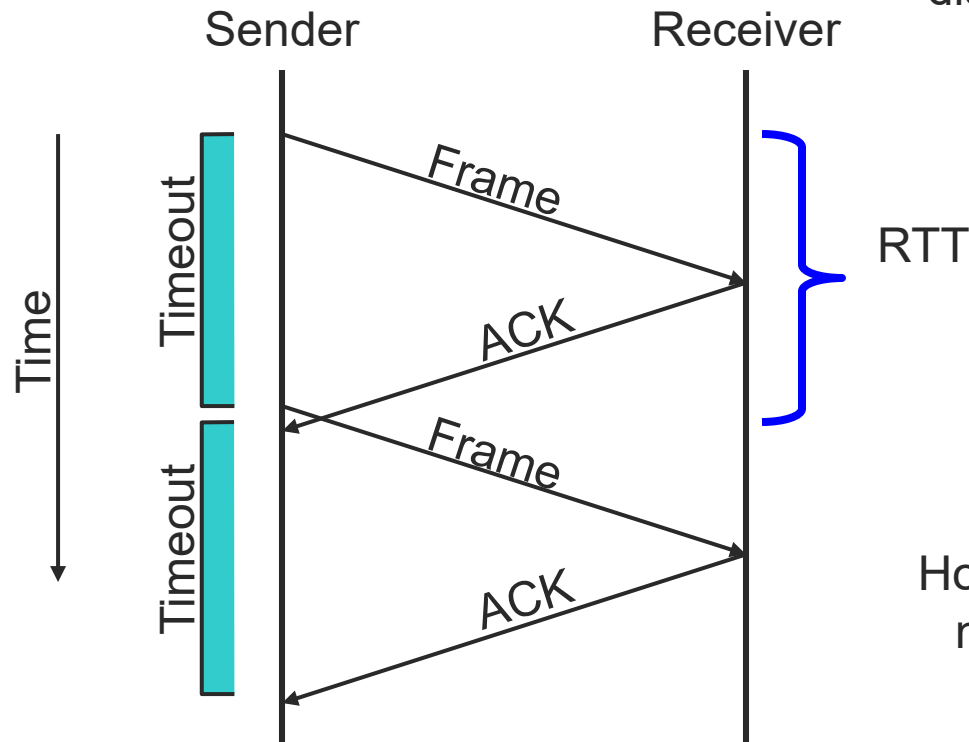

How can receiver distinguish between two frames?

How many bits do you need for sequence numbers?



[Stop-and-Wait]

- Goal
 - Guaranteed, at-most-once delivery
- Protocol Challenges
 - Dropped frame/ACK
 - Duplicate frame/ACK
- Requirements
 - 1-bit sequence numbers (if physical network maintains order)
 - sender tracks frame ID to send
 - receiver tracks next frame ID expected



Stop-and-Wait State Diagram

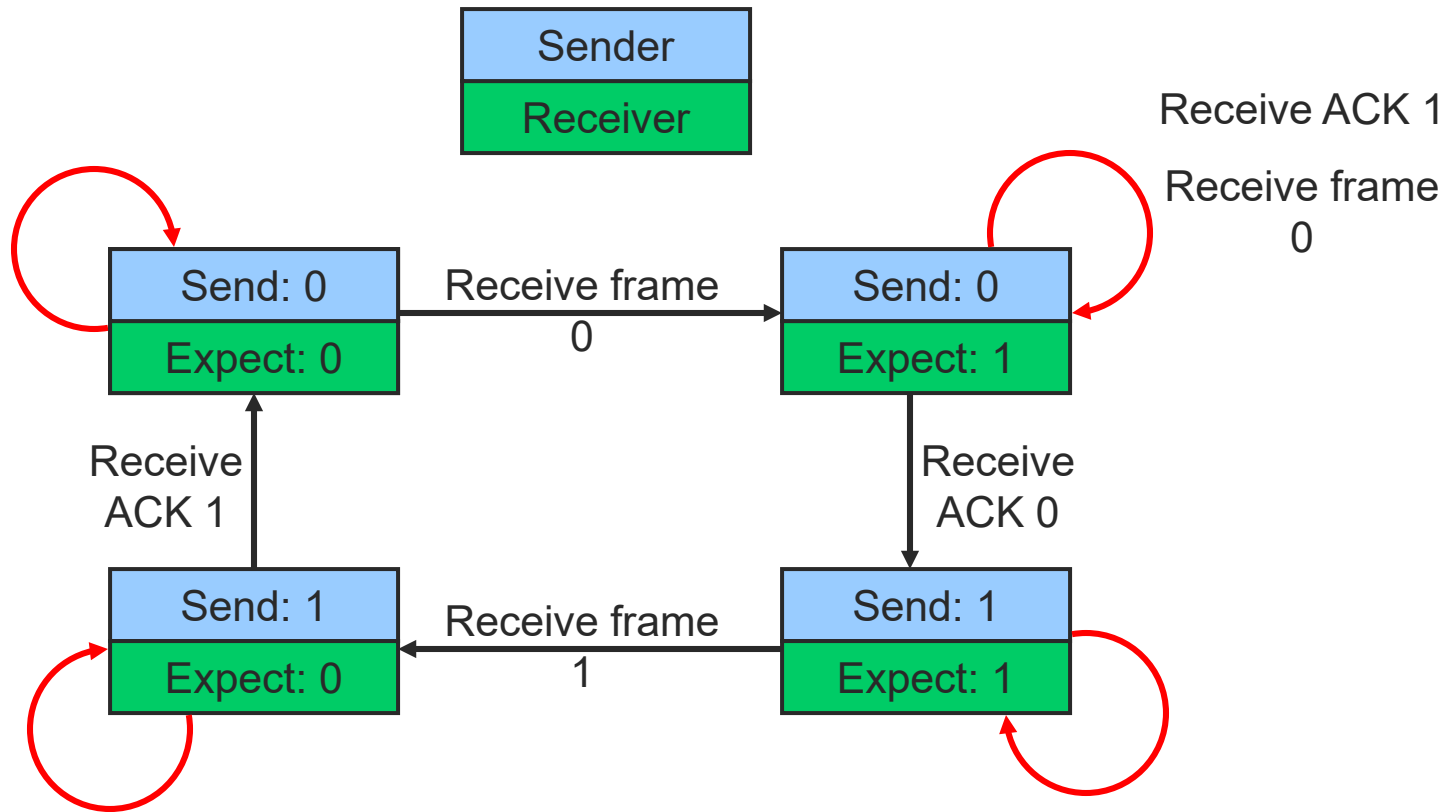

[Stop-and-Wait]

- We have achieved
 - Frames delivered reliably and in order
 - Is that enough?
- Problem
 - Only allows one outstanding frame
 - Does not keep the pipe full
 - Example
 - 100ms RTT
 - One frame per RTT = 1KB
 - $1024 \times 8 \times 10 = 81920$ kbps
 - Regardless of link bandwidth!



Concurrent Logical Channels

- Used in ARPANET IMP-IMP protocol
- Idea
 - Multiplex logical channels over a physical link
 - Include channel ID in header
 - Use stop-and-wait for each channel
- Result
 - Each channel is limited to stop-and-wait bandwidth
 - Aggregate bandwidth uses full physical channel
 - Supports multiple communicating processes
 - Can use more than one channel per process



Concurrent Logical Channels

■ Problem

○ Bandwidth

- Use of a single channel per process may waste BW

○ Ordering

- Use of multiple channel per process does not maintain packet ordering across channels!
- If application has n channels, and one needs a retransmission, it will always be one packet behind the other channels



[ARQ: Where are We?]

- Goals for reliable transmission
 - Make channel appear reliable
 - Maintain packet order (usually)
 - Impose low overhead/allow full use of link
- Stop-and-Wait
 - Provides reliable in-order delivery
 - Sacrifices performance
- Concurrent Logical Channels
 - Provides reliable delivery at full link bandwidth
 - Sacrifices packet ordering
- Sliding Window Protocol
 - Achieves all three!



[Sliding Window Protocol]

- Most important and general ARQ algorithm
- Used by TCP
- Outline
 - Concepts
 - Terminology (from P&D)
 - Details
 - Code example
 - Proof of eventual in-order delivery
 - Classification scheme
 - (go-back-n, selective repeat)



Keeping the Pipe Full

Stop-and-Wait

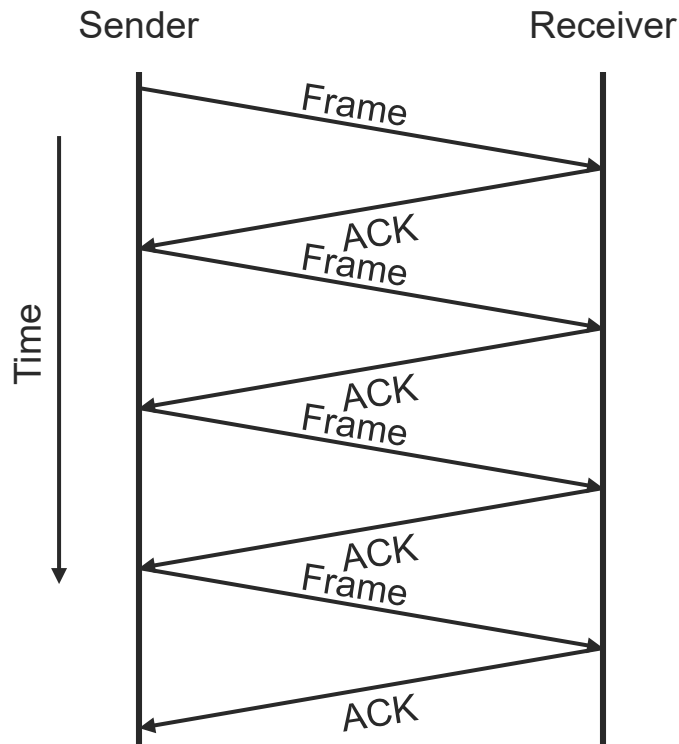

Goal

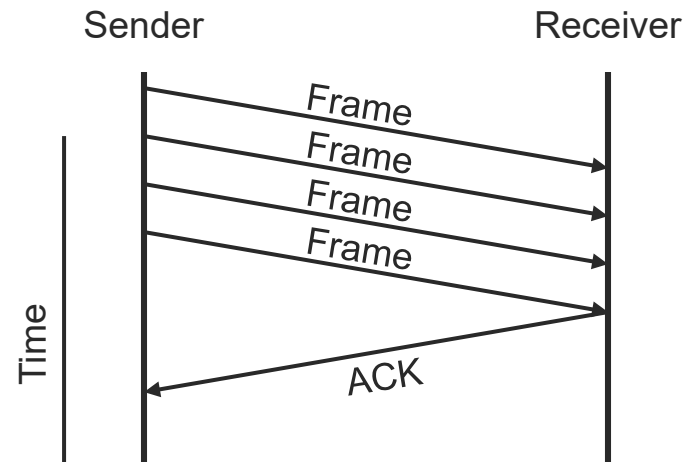

Advantages:

- More frames in pipe
- Less time overall
- Piggybacked ACKs



[Concepts]

- Consider an ordered stream of data frames
- Stop-and-Wait
 - Window of one frame
 - Slides along stream over time



[Concepts]

- Sliding Window Protocol
 - Multiple-frame send window
 - Multiple frame receive window

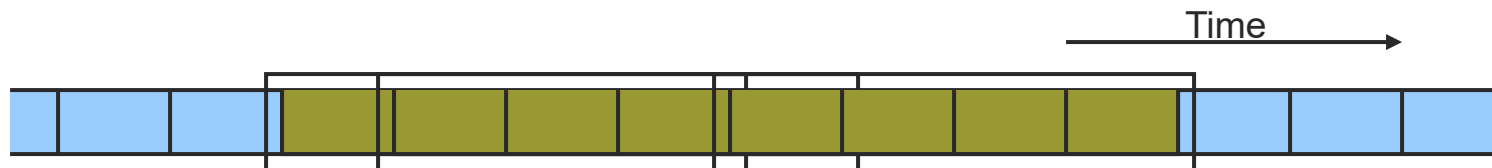

[Sliding Window]

- Send Window

- Fixed length
- Starts at earliest unacknowledged frame
- Only frames in window are active

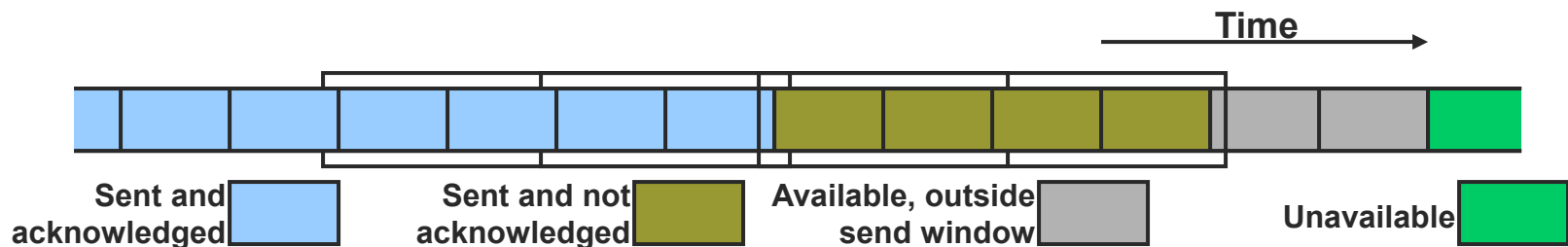

[Sliding Window]

■ Receive Window

- Fixed length (unrelated to send window)
- Starts at earliest frame not received
- Only frames in window accepted



Sliding Window Terminology

■ Sender Parameters

- Send Window Size (**SWS**)
- Last Acknowledgement Received (**LAR**)
- Last Frame Sent (**LFS**)

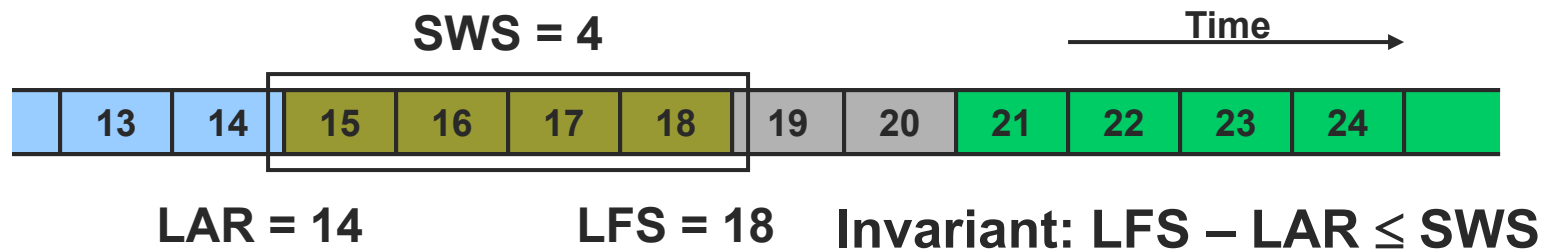

Sliding Window Terminology

Receiver Parameters

- Receive Window Size (**RWS**)
- Next Frame Expected (**NFE**)
- Last Frame Acceptable (**LFA**)

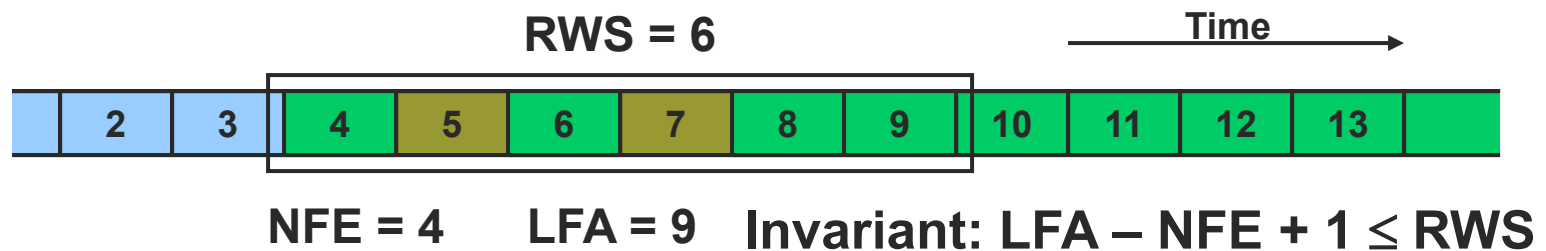

Sliding Window Details

- Sender Tasks
 - Assign sequence numbers
 - On ACK Arrival
 - Advance LAR
 - Slide window

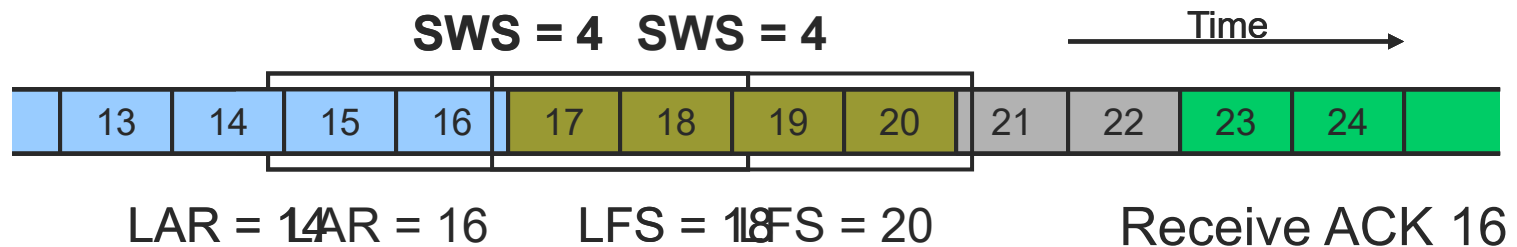

Sliding Window Details

Receiver Tasks

On Frame Arrival (N)

- Silently discard if outside of window
 - $N < \text{NFE}$ (NACK possible, too)
 - $N \geq \text{NFE} + \text{RWS}$
- Send cumulative ACK if within window

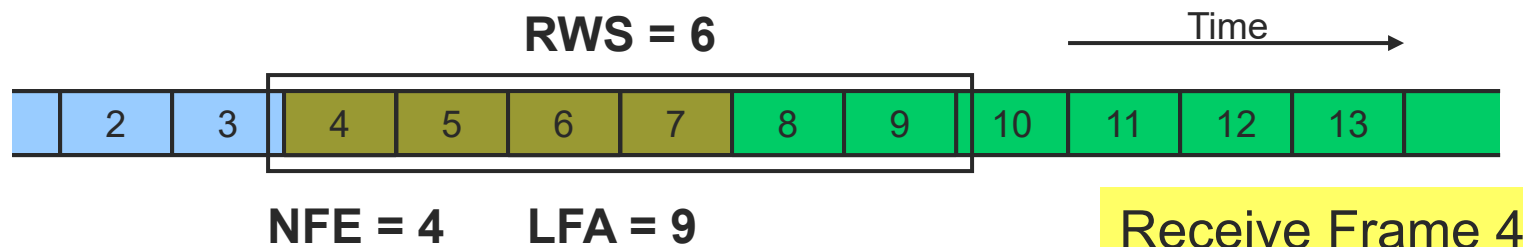

Sliding Window Details

- Receiver Tasks
 - On Frame Arrival (N)
 - Silently discard if outside of window
 - $N < NFE$ (NACK possible, too)
 - $N \geq NFE + RWS$
 - Send cumulative ACK if within window

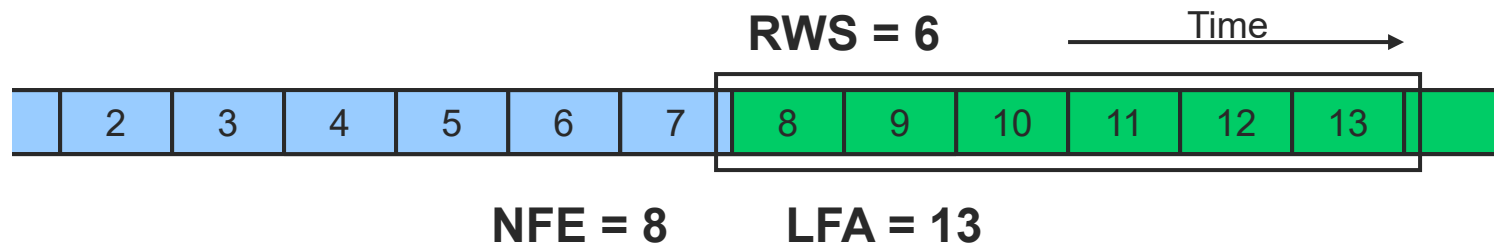

[Sliding Window Details]

- Sequence number space
 - Finite number, so wrap around
 - Need space larger than SWS (outstanding frames)
 - In fact, need twice as large
- Example
 - 3-bit sequence numbers (0-7)
 - $RWS = SWS = 7$



Sliding Window Details

- Is $\log_2(SWS+1)$ bits enough?
 - No. Example:
 - 3-bit sequence numbers (0-7)
 - $RWS = SWS = 7$
 - Why isn't 3 bits enough (can you think of an example where it doesn't work?)



Sliding Window Details

- Example of incorrect behavior
 - 3-bit sequence numbers 0-7
 - $RWS = SWS = 7$
 - Sender transmits 0-6
 - All arrive, but ACK's lost
 - Sender retransmits
 - Receiver accepts as second incarnation of 0-6

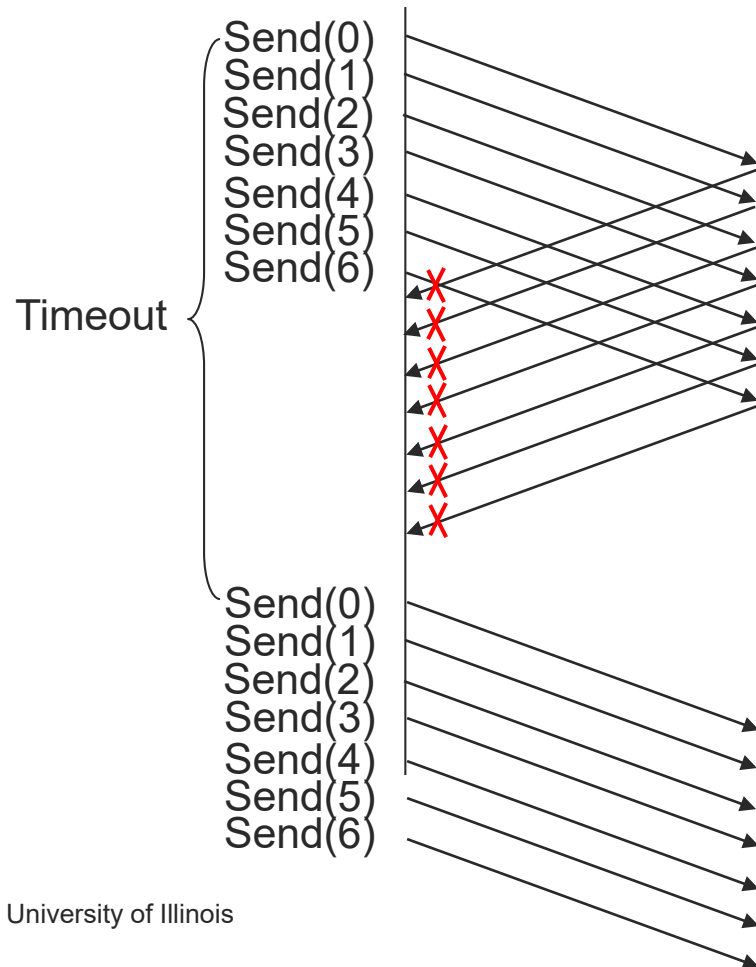

Sliding Window Sequence Numbers

- How many sequence numbers are necessary?
 - Key questions
 - Where can the send window be?
 - What frame can be received next?



Sliding Window Sequence Numbers

- Assume **SWS = RWS** (simplest, and typical)
- Sender transmits full SWS
- Two extreme cases:
 - None received (waiting for **0...SWS - 1**)
 - All received (waiting for **SWS...2 SWS - 1**)
- All possible packets must have unique sequence numbers

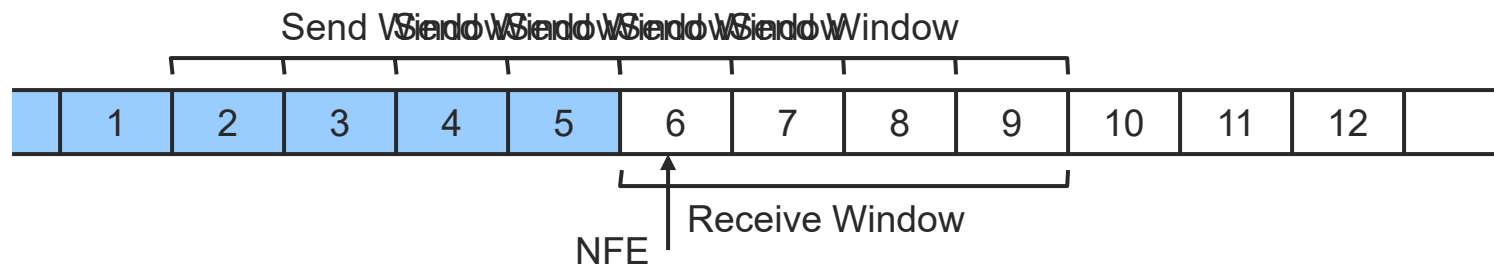

Sliding Window Sequence Numbers

- Extreme Locations for SWS
- Requirements
 - If a received packet is not in the receive window with no wrap, then it must not be in the receive window with wrap!
- Correctness condition:
 - **Number of Sequence Numbers \geq SWS + RWS**
 - Alternates between two halves of the sequence number space

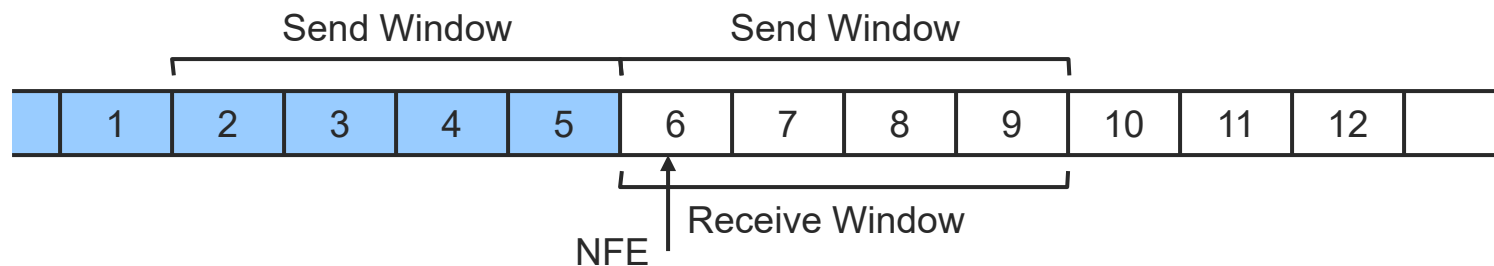

Sliding Window Sequence Numbers

■ Example

- If $SWS = RWS = 8$
- At least 16 sequence numbers are needed
- A 4-bit sequence number space is enough

■ Warning

- P&D sometimes uses the variable `Max_Seq_Num` for the number of sequence numbers and sometimes for the maximum sequence number (these differ by one!)
- Use `Num_Seq_Num` for the number of sequence numbers: $0, 1, \dots, \text{Num_Seq_Num} - 1$



[Window Sizes]

- How big should we make SWS?
 - Compute from delay x bandwidth
- How big should we make RWS?
 - Depends on buffer capacity of receiver



Delay x Bandwidth Product - Revisited

- Amount of data in “pipe”
 - channel = pipe
 - delay = length
 - bandwidth = area of a cross section
 - bandwidth x delay product = volume



Delay x Bandwidth Product

- Bandwidth x delay product
 - How many bits the sender must transmit before the first bit arrives at the receiver if the sender keeps the pipe full
 - Takes another one-way latency to receive a response from the receiver

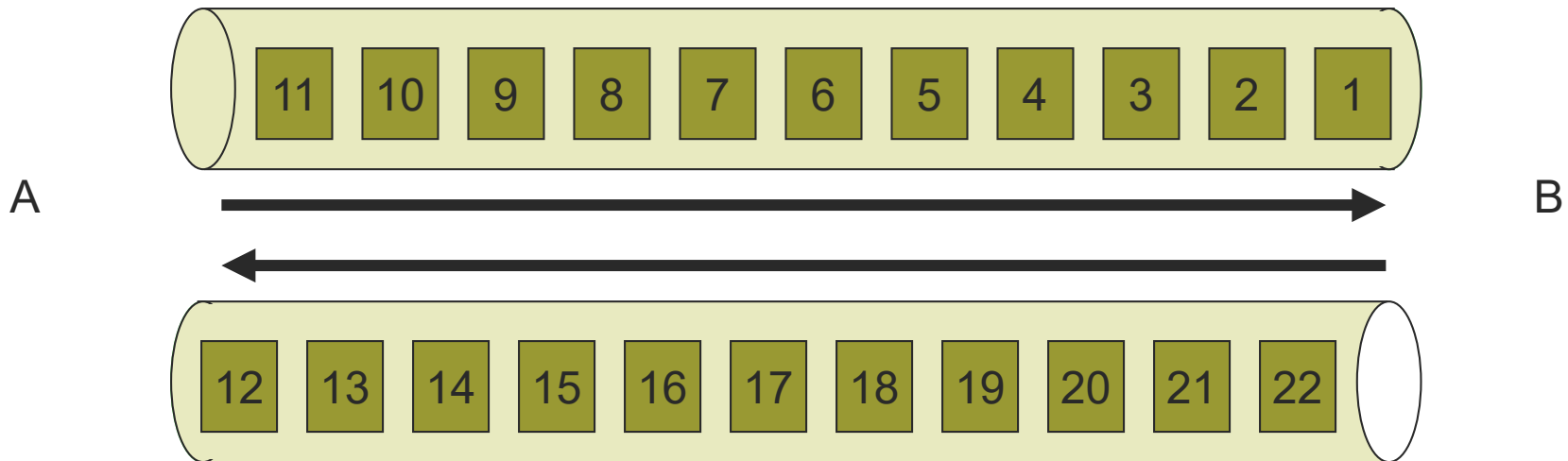

Sliding Window Protocol Code Example

■ Parameters

- last acknowledgement received (**LAR**)
- last frame sent (**LFS**)
- next frame expected (**NFE**)
- last frame acceptable (**LFA**)



Sliding Window Protocol Code Example

■ Constants

- Rend/receive window size (**SWS/RWS**)
- Maximum sequence number (**MAX_SEQ_NO**)
- Frame size (**FRAME_SIZE**, constant for simplicity)



Sliding Window Protocol Code Example

- Data structures
 - Next frame expected (an integer)
 - One frame buffer for each entry in receive window
 - One presence bit for each entry
- Receive window cycles through
 - Sequence numbers
 - Data structures (thus RWS must divide MAX_SEQ_NO)



Sliding Window Protocol Code

Example

```
#define RWS          8          /* receive window size      */
#define MAX_SEQ_NO  16          /* max. sequence number+1  */
                                /* (must be multiple of    */
                                /* RWS for this code)     */
#define FRAME_SIZE  1000       /* constant for simplicity*/

char buf[RWS][FRAME_SIZE];     /* RWS frame buffers        */
int present[RWS];              /* are frame buffers full? */
                                /* (initialized to 0's)    */
int NFE = 0;                   /* next frame expected     */
extern void send_ack (int seq_no);
extern void pass_to_app (char* data);
void recv_frame (char* data, int seq_no);
```



Sliding Window Protocol Code Example

```
void recv_frame (char* data, int seq_no)
{
    int idx;          /* index into data structures */
    int i;           /* loop index */

    /* Map sequence numbers NFE...predecessor (NFE)
       into 0...MAX_SEQ_NO - 1, then see if seq_no
       falls within the receive window. */
    if (seq_no - NFE) < RWS)

        /* Frames outside the window */
        /* are ignored. (but an ACK */
        /* is sent; why?) */
```



Sliding Window Protocol Code Example

```
/* Calculate index into data structures. */  
idx = (seq_no % RWS);  
  
if (!present[idx]) { /* frame is not dup */  
    present[idx] = 1; /* mark received      */  
    memcpy (buf[idx], data, FRAME_SIZE);  
                /* copy data into buf */
```



Sliding Window Protocol Code Example

```
/* Got a new frame; pass frames up to host? */
for (i = 0; i < RWS; i++) {
    idx = (i + NFE) % RWS;      /* Re-use idx.*/
    /* first missing frame becomes NFE */
    /* after this loop terminates */
    if (!present[idx]) break;

    /* Frame is present—send it up! */
    pass_to_app (buf[idx]);
    present[idx] = 0; /* Mark buffer empty. */
}
/* Advance NFE to first missing frame. */
NFE = NFE + i;
}
```



Sliding Window Protocol Code Example

```
        /* Frame handled (might have */  
        /* been duplicate). */  
    } /* (Send ACK for any frame received */  
  
    /* Now send acknowledgement for          */  
    /* predecessor (NFE).                    */  
    send_ack (NFE - 1);  
}
```



[Correctness]

- Claim
 - A sliding window protocol leads to in-order delivery of all frames
- Assumptions
 - All sequence numbers are different
 - Frames can be lost
 - Frames can be delayed an arbitrarily finite amount of time
 - Frames are not reordered
 - Frames can arrive with detectable errors
- Are these assumption adequate?



Sliding Window Protocol Correctness

- Need one more assumption
 - Any given frame is received without errors after a finite number of retransmissions
- Proof in two steps
 - Establish correctness assuming infinite sequence number space
 - Show that finite sequence number space does not affect result as long as it has $\geq 2 \max(\text{SWS}, \text{RWS})$ possible numbers



Sliding Window Protocol Correctness

- Step 1: establish correctness assuming infinite sequence number space
 - Use induction on k with invariant “the k^{th} frame is eventually received”
- Step 2: show that finite sequence number space does not affect result as long as it has $\geq 2 \max(\text{SWS}, \text{RWS})$ possible numbers

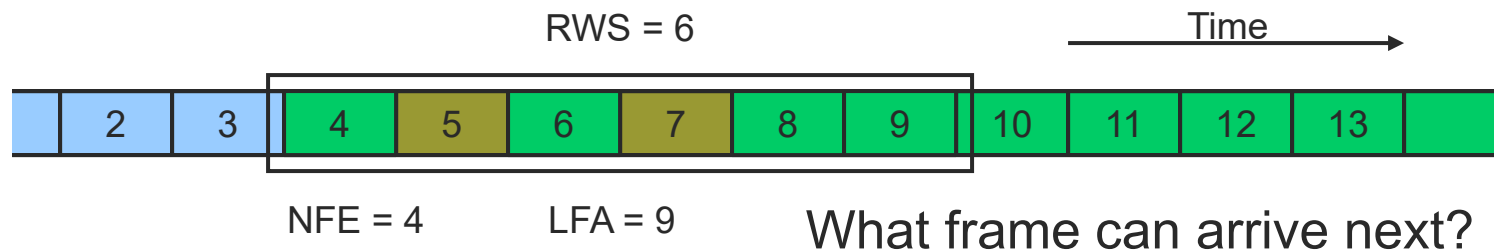

[ARQ Algorithm Classification]

- Three Types:

- Stop-and-Wait: $SWS = 1$ $RWS = 1$
- Go-Back-N: $SWS = N$ $RWS = 1$
- Selective Repeat: $SWS = N$ $RWS = M$
 - Usually $M = N$

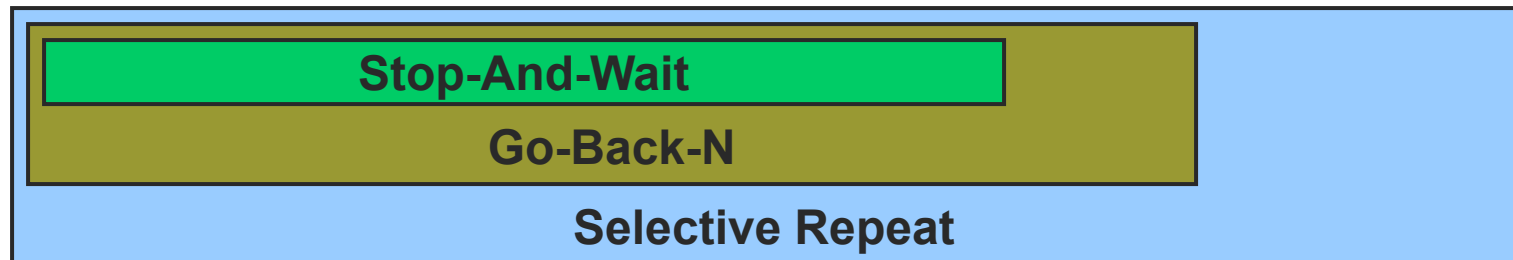

Sliding Window Variations: Go-Back-N

- $SWS = N, RWS = 1$
- Receiver only buffers one frame
- If a frame is lost, the sender may need to retransmit up to N frames
 - i.e., sender “goes back” N frames
- Variations
 - How long is the frame timeout?
 - Does receiver send NACK for out-of-sequence frame?



Go-Back-N: Cumulative ACKs

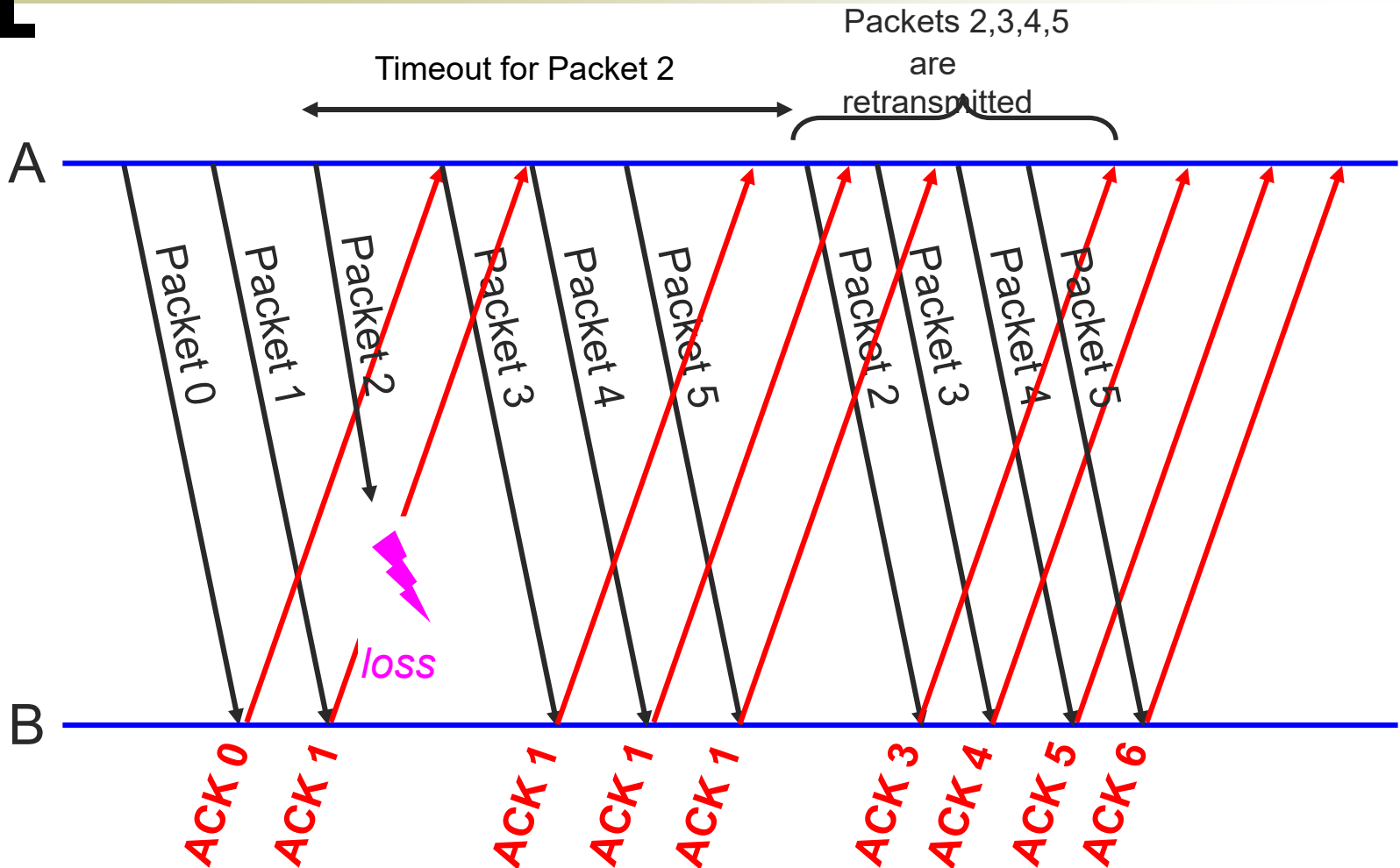

Sliding Window Variations: Selective Repeat

- $SWS = N, RWS = M$
- Receiver buffer M frames
- If a frame is lost, sender must only resend
 - Frames lost within the receive window
- Variations
 - How long is the frame timeout?
 - Use cumulative or per-frame ACK?
 - Does protocol adapt timeouts?
 - Does protocol adapt SWS and/or RWS ?



Selective Repeat

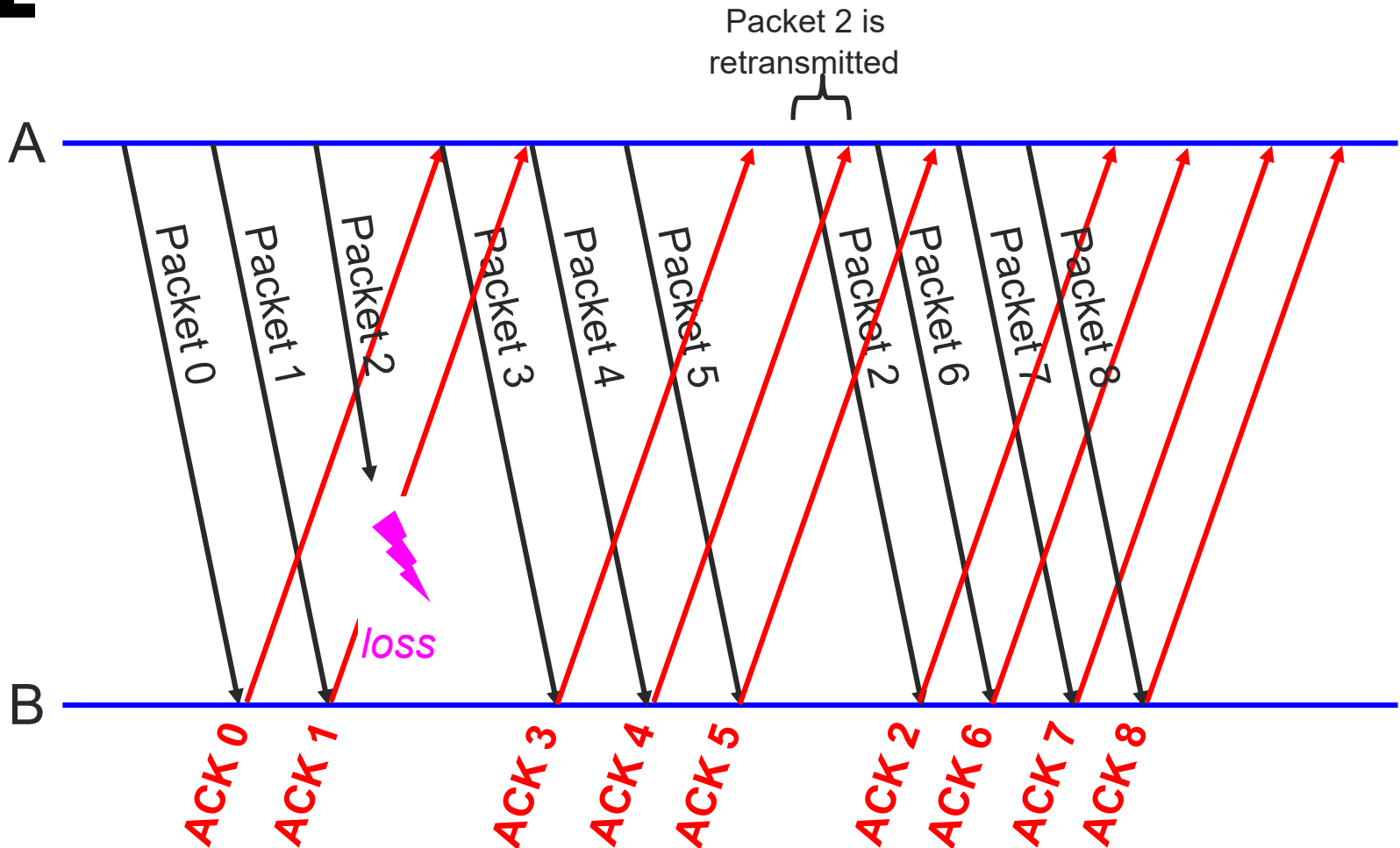

Roles of a Sliding Window Protocol

- Reliable delivery on an unreliable link
 - Core function
- Preserve delivery order
 - Controlled by the receiver
- Flow control
 - Allow receiver to throttle sender
- Separation of Concerns
 - Must be able to distinguish between different functions that are sometimes rolled into one mechanism



Forward Error Correction (FEC)

- Alternative to ARQ algorithms
- Idea
 - Error correction instead of error detection
 - Send extra information to avoid retransmission (i.e., fix errors first/forward rather than afterward/backward)
- Why
 - Very high latency connections
 - Difficult for retransmission

