

Static Structures and Finite Element Analysis

Brian Mercer
Mechanical Science and Engineering



I ILLINOIS
Mechanical Science & Engineering
GRAINGER COLLEGE OF ENGINEERING

What is the finite element method?

- The **F**inite **E**lement **M**ethod (FEM) is a mathematical framework that can be used to find approximate solutions to **p**artial **d**ifferential **e**quations (PDEs)
- PDEs describe lots of important physics, including
 - Solid mechanics (e.g. linear elasticity)
 - Fluid mechanics
 - Heat transfer
 - Electromagnetism
- **F**inite **E**lement **A**nalysis (FEA) involves the practical application of the finite element method to solve a real-world problem.

Why is FEA helpful?

- Most real-world problems are too complex to analyze by hand
- But, we'd like a way to estimate stresses and deformations in engineering components and structures. FEA, when used correctly, can help!

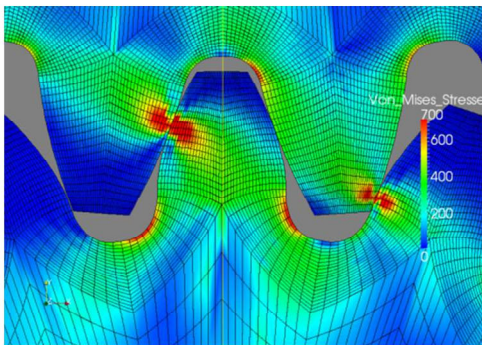

Gears in contact: what is the stress field in each of the gear teeth?

<https://www.thetruthaboutcars.com/2014/07/saturation-dive-manual-transmission-gear-design/>

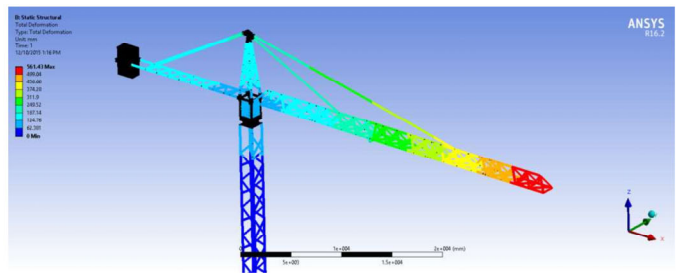

Large crane structure: how much deformation and stress does this structure experience under a given load?

<https://www.finiteelementanalysis.com.au/featured/analysing-large-fabricated-structures/>

Why is FEA helpful?

- Benefits of FEA:
 - Analyze complex geometries based on CAD models of parts to be designed/manufactured
 - Efficient for planning and prototyping
 - Quicker to test more variables under more situations
 - Is your test destructive? Destroy it in a simulation instead! It's cheaper
 - Bottom line: saves time/money when done well
- Limitations include:
 - Models are always an **approximation** of reality
 - Complexity and learning curve of FEA software
 - Cost: very large models take time (days, or longer!) for the computer to solve

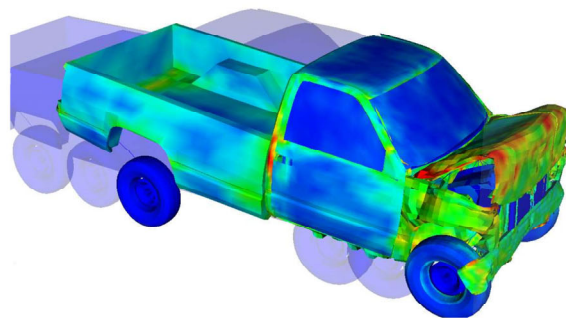

<https://enteknorate.com/>

FEM for Structural Analysis

Step 1: Define the problem: geometry, boundary conditions, material properties

Step 2: Mesh (discretize) the domain into **nodes** and **elements**

Step 3: Solve the model to obtain nodal **displacements**

Step 4: Post-process the model to obtain element **stresses**

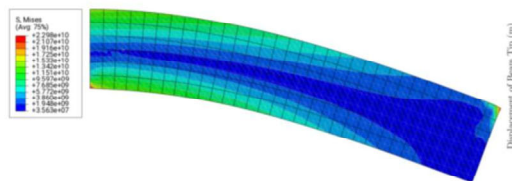
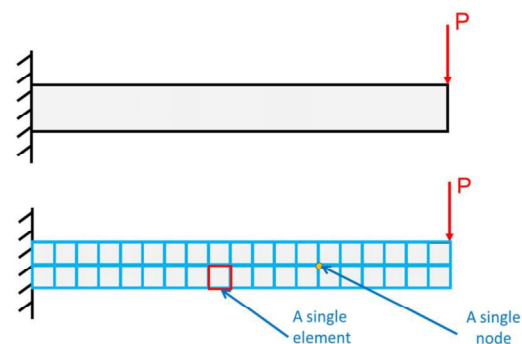

<https://www.simscale.com/blog/2017/01/convergence-finite-element-analysis/>

Step 1: Define the Problem

Defining the Problem requires

1. **Defining geometry** (e.g. from a CAD model of the part/structure)
2. **Defining material properties** (e.g. Young's modulus and Poisson's ratio for an isotropic linear elastic material; more complex materials need additional parameters)
3. **Boundary conditions:** These come in two general types
 1. **Displacement:** Portions of the boundary have defined deformation (often, fixed due to a structural support)
 2. **Force/Traction:** Portions of the boundary experience external loading (concentrated load, distributed load, pressure load, etc)

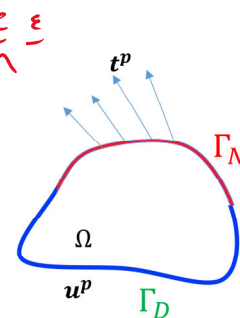

A large challenge in FEA modeling stems from transforming a real-life problem into a mathematical representation of the problem with realistic loads and constraints.

Step 2: Meshing

In FEA, a continuous structure is transformed into a collection of inter-connected elements. Elements come in a variety of shapes. Below is an example of a 4-node quadrilateral element that can be used to model a 2D structural problem.

Each quadrilateral element has 4 nodes, and two **degrees of freedom** per node (u_x^i and u_y^i , the horizontal and vertical displacement of node i)

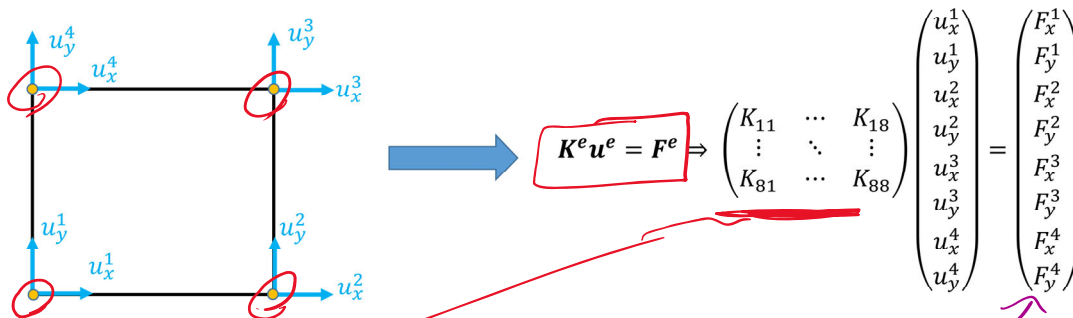

The element **stiffness matrix** and **load vector** relate the nodal **displacements** to **forces** applied on the nodes. This relationship can be derived from equilibrium/energy minimization principles in structural mechanics.

Steps 3 and 4: Solving and Post-Processing

Step 3: Solving the model:

- Once boundary conditions have been specified and the model has been meshed, FEA software gathers **(Assembles)** all of the equations relating nodal displacements to one another and assembles them into a linear system $Ku = F$.
- $u = K^{-1}F$ Solving the system of equations gives the displacement of every node in the model. The computing cost to complete this solve increases with the number of degrees of freedom in the model.

Step 4: Post-processing: Once all nodal displacements are known, FEA software can generate useful outputs such as:

- The deformed shape of the structure
- A contour plot of the stress distribution in the structure

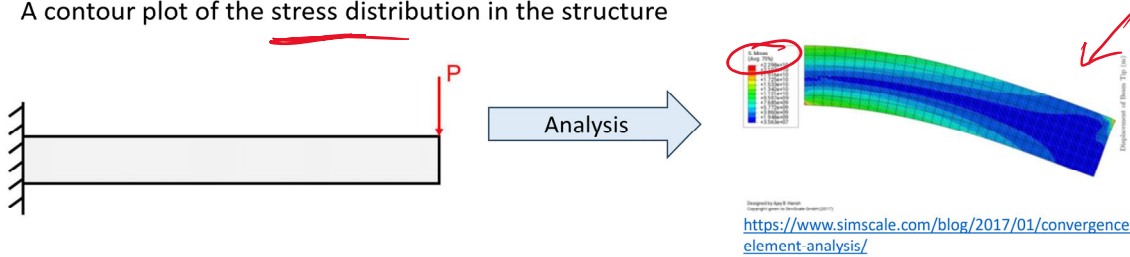

I Mechanical Science & Engineering



FEA Boundary Conditions: Example

Consider a wrench applying torque to a bolt head. Suppose we wish to use FEA to calculate the stresses in the wrench in this situation.

Sketch a model of the boundary conditions you could use to model this problem. Assume the user applies load along the handle, but the torque is low enough that the bolt doesn't begin to turn.

Hint: How could you represent the presence of the bolt with boundary conditions? ?

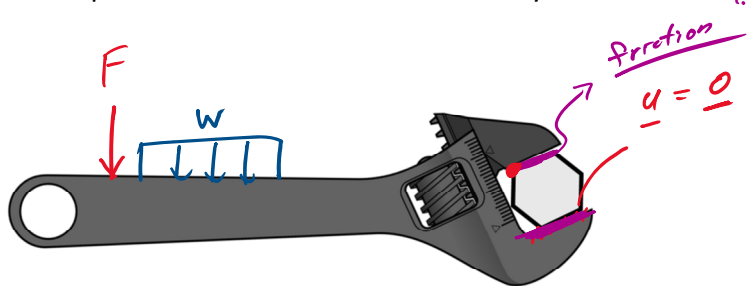

Types of Elements

The most common types of finite elements are summarized in the figure below.

- Elements interpolate the displacement field between nodes.
- The displacement field is typically either modeled with a linear or quadratic polynomial.

What type of element should you use? Several factors

- **Cost:** linear elements are computationally cheaper/simpler to work with
- **Geometry:** Triangular elements easily mesh a domain; quadratic elements can have curved edges
- **Type of problem being solved:** E.g., linear triangles/tetrahedra don't capture bending deformation very accurately

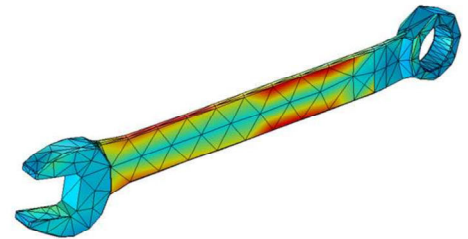
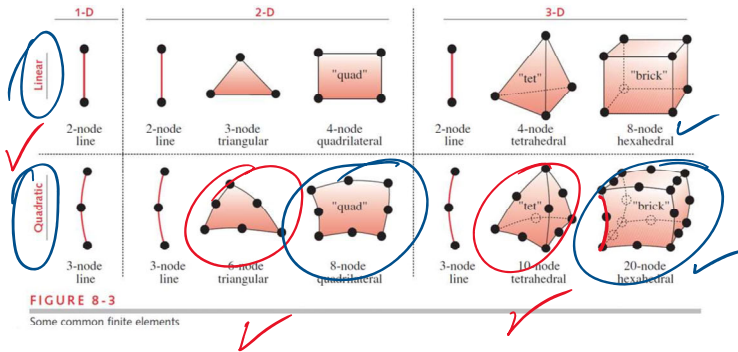

FEA Solution Convergence

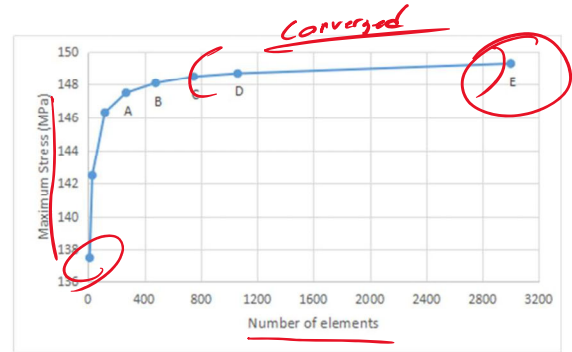
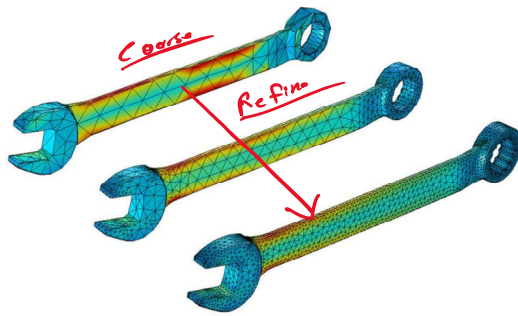

An example of mesh refinement of an FEA model of a wrench.
<https://www.comsol.com/multiphysics/mesh-refinement>

Example of a plot to detect solution convergence
<https://caeuniversity.com/mesh-convergence-modern/>

- When two successive refinements result in only a small difference in the FEA solution, we say the solution has **converged**
- Mesh refinement can be done manually by the user or by using automatic routines in the software
- It's best to use only as many elements/nodes as you need for convergence in a given model
- You should always ensure your FEA model has converged!

Model Validation

Model **validation** involves checking the results of your model against reality, e.g. documented experiments, performing your own tests or experiments, etc.

In our wrench example, if we observed the failure mode below, but the FEA model predicted the highest stresses to be in another part of the structure, it would warrant double-checking problem inputs like material properties, revisiting the boundary conditions to determine if they are adequate for the true loading scenario, etc.



Download from
Dreamstime.com
This watermarked comp image is for previewing purposes only.



ID 13976698
Sever180 | Dreamstime.com

FEA with Linear Rod Elements

The linear rod element is one of the simplest possible structural elements.

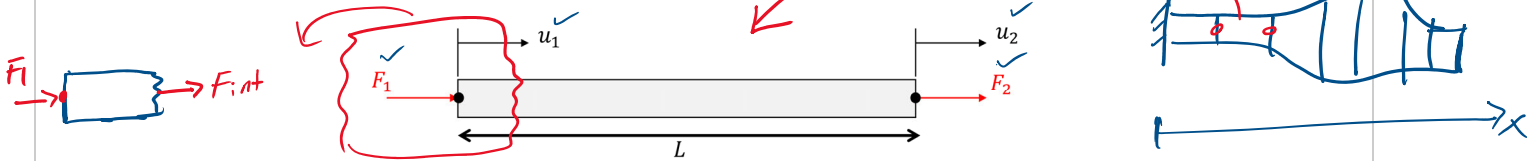

- A linear rod has 2 nodes with nodal displacements u_1 and u_2 and nodal forces F_1 and F_2 .
- The rod has constant cross-sectional area A and elastic modulus E , and the length of the rod is L .
- It can only take axial loads (no bending, twisting, etc).

From equilibrium analysis, we know that $F_{int} = -F_1 = F_2 = \frac{EA}{L}(u_2 - u_1)$. Therefore, we can write two equations:

$$F_1 = \frac{EA}{L}(u_1 - u_2), \quad F_2 = \frac{EA}{L}(-u_1 + u_2)$$

Or in matrix form:

$$\frac{EA}{L} \begin{bmatrix} 1 & -1 \\ -1 & 1 \end{bmatrix} \begin{bmatrix} u_1 \\ u_2 \end{bmatrix} = \begin{bmatrix} F_1 \\ F_2 \end{bmatrix}$$

This gives us the **stiffness matrix** and **load vector** for a 1D rod element: $\mathbf{K}^e = \frac{EA}{L} \begin{bmatrix} 1 & -1 \\ -1 & 1 \end{bmatrix}$, and $\mathbf{F}^e = \begin{bmatrix} F_1 \\ F_2 \end{bmatrix}$ (applied loads at the nodes)

FEA with Linear Rod Elements

Suppose we wish to find the total **elongation** of the structure below, which consists of **two rod elements** of the same length L , modulus E , and cross-sectional area A , connected in series. There are two elements and a total of 3 nodes

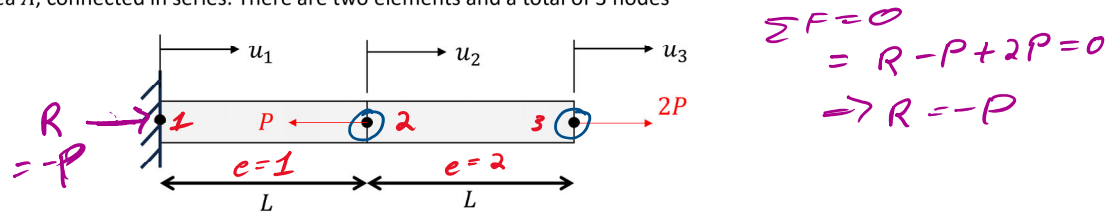

To find the stiffness matrix and load vector for this system, we can use assembly, which is a key feature of FEA solution strategies.

To assemble the global stiffness matrix, we compute each element stiffness and note its contribution to the global stiffness matrix, which is 3x3 in size due to the 3 total displacement DOF in the system:

$$\begin{aligned}
 & K^e = \frac{EA}{L} \begin{bmatrix} 1 & -1 \\ -1 & 1 \end{bmatrix} \\
 & K_1^e = \frac{EA}{L} \begin{bmatrix} 1 & -1 & 0 \\ -1 & 1 & 0 \\ 0 & 0 & 0 \end{bmatrix} \begin{matrix} 1 \\ 2 \\ 3 \end{matrix} \quad K_2^e = \frac{EA}{L} \begin{bmatrix} 0 & 0 & 0 \\ 0 & 1 & -1 \\ 0 & -1 & 1 \end{bmatrix} \begin{matrix} 1 \\ 2 \\ 3 \end{matrix} \rightarrow K = K_1^e + K_2^e = \frac{EA}{L} \begin{bmatrix} 1 & -1 & 0 \\ -1 & 2 & -1 \\ 0 & -1 & 1 \end{bmatrix}
 \end{aligned}$$

F contains the loads applied to each node: (R is an unknown placeholder for the wall reaction force)

$$F = \begin{bmatrix} R \\ -P \\ 2P \end{bmatrix} \begin{matrix} 1 \\ 2 \\ 3 \end{matrix}$$

↳ Global stiffness

FEA with Linear Rod Elements

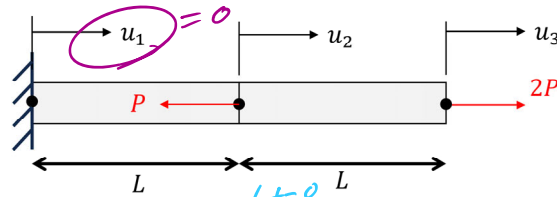

Hence the global assembled system of equations is $Ku = F$:

$$\frac{EA}{L} \begin{bmatrix} 1 & -1 & 0 \\ -1 & 2 & -1 \\ 0 & -1 & 1 \end{bmatrix} \begin{bmatrix} u_1 \\ u_2 \\ u_3 \end{bmatrix} = \begin{bmatrix} R \\ -P \\ 2P \end{bmatrix}$$

Handwritten notes: circled '1' in the first row, 'det=0' above the matrix, and 'u1=0' next to the displacement vector.

Because the rod is fixed at the wall, $u_1 = 0$, which allows us to modify the system of equations to read:

$$\frac{EA}{L} \begin{bmatrix} 2 & -1 \\ -1 & 1 \end{bmatrix} \begin{bmatrix} u_2 \\ u_3 \end{bmatrix} = \begin{bmatrix} -P \\ 2P \end{bmatrix} \Rightarrow u = K^{-1} F \text{ to find } u_2, u_3$$

We can solve this to obtain $u_2 = \frac{PL}{EA}$, $u_3 = 3\frac{PL}{EA}$

We can revisit the first row of the original equation if we want to compute the wall reaction: $R = \frac{EA}{L}(u_1 - u_2) = -P$

$$\frac{EA}{L} [\underbrace{1 \cdot u_1}_{=0} - \underbrace{1 \cdot u_2}_{\frac{PL}{EA}} + \underbrace{0 \cdot u_3}_{\frac{3PL}{EA}}] = R$$

$\Rightarrow R = -P$

FEA with Linear Rod Elements

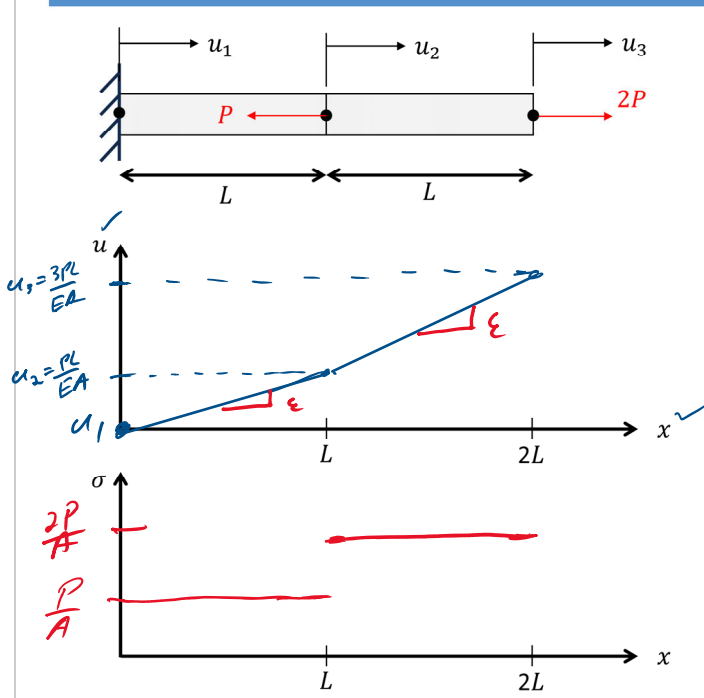

$$\epsilon = \frac{du}{dx}$$

In the linear rod element, the strain in each element is **constant**, and since $\sigma = E\epsilon$ for linear elasticity, so is the stress

Displacement is the integral of strain ($\epsilon = \frac{du}{dx} = \frac{\Delta u}{\Delta x}$), so the displacement field is **linear** in each element.

Let's make plots of the FEA displacement field and stress field on the axes below.

Recall the solution $(u_1, u_2, u_3) = (0, \frac{PL}{EA}, 3\frac{PL}{EA})$ for this problem:

element 1

$$\epsilon_1 = \frac{u_2 - u_1}{L} = \frac{P}{EA}$$

$$\sigma_1 = E\epsilon_1 = \frac{P}{A}$$

Element 2

$$\epsilon_2 = \frac{u_3 - u_2}{L} = \frac{2P}{EA}$$

$$\sigma_2 = E\epsilon_2 = \frac{2P}{A}$$

Appendix

The following slides give some more background and key equations from the theory of linear elasticity, which may be helpful in setting up FEA simulations and interpreting results.

This information can also be found in most introductory texts on solid mechanics or the finite element method.

MEL 1001

Kinematics of a deforming body

Undeformed body

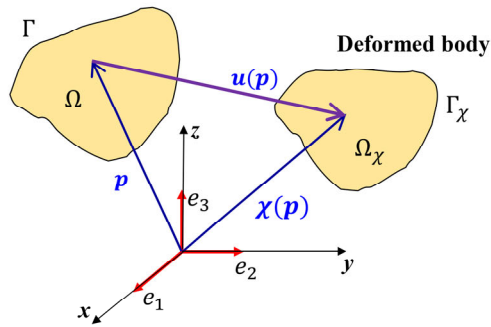

Undeformed (or initial) configuration:

- Volume Ω
- Boundary $\Gamma = \Gamma_D \cup \Gamma_N$
- Γ_D : boundary where displacement is prescribed (essential BC)
- Γ_N : boundary where traction is prescribed (natural BC)
- Points in the body are defined by the **position vector \mathbf{p}**

Deformed configuration:

After forces are applied, the body assumes a new configuration defined by the **deformation $\chi(\mathbf{p})$**

The **displacement $\mathbf{u}(\mathbf{p})$** is defined such that $\mathbf{u}(\mathbf{p}) = \chi(\mathbf{p}) - \mathbf{p}$

Note that so far no assumptions were made regarding the magnitude of the deformation

Kinematics for linear elasticity

Undeformed body

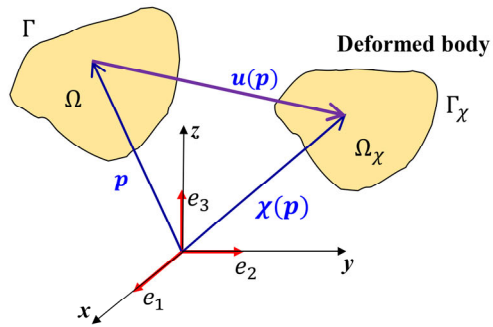

In linear elasticity, we assume the deformed configuration involves only small deformations (strains)

Therefore, **we do not differentiate between the deformed and undeformed configuration**. This simplifies many things:

- Strains and stresses are measured relative to the original geometry (i.e. engineering stress/strain is applicable)
- Applied loads don't change direction as a body deforms
- **Linear** constitutive law linking stress and strain

The displacement field $\mathbf{u}(\mathbf{p}) = \chi(\mathbf{p}) - \mathbf{p}$ might have large magnitudes, but its gradient $\nabla \mathbf{u}$ is "small" in this treatment.

Kinematics for linear elasticity

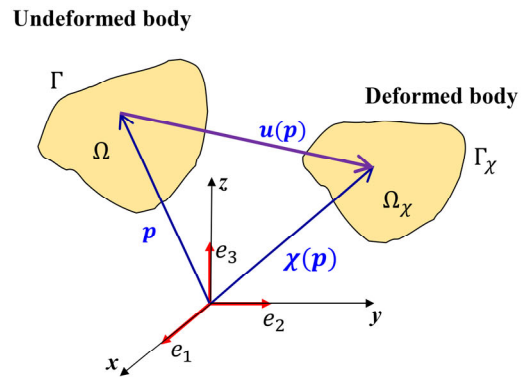

These lectures notes will use (x, y, z) interchangeably with (x_1, x_2, x_3) to express the Cartesian coordinate variables

x_i is the coordinate associated with the unit vector e_i

Using numbers allows for some more convenient notation, for example

$$(\nabla \mathbf{u})_{ij} = \frac{\partial u_i}{\partial x_j}$$

Clearly communicates the components of the gradient of the vector \mathbf{u}

Small-strain (linear) elasticity

Engineering **normal** strain: **length** change

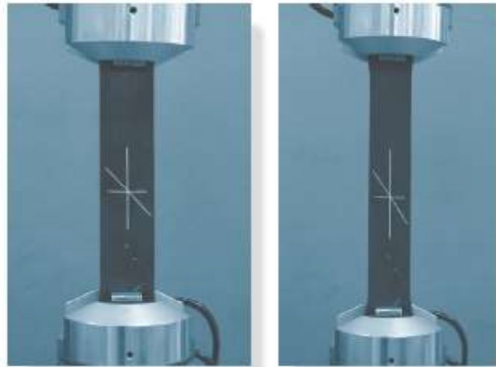

Rubber membrane subject to tension

Normal strains characterize length change along a specific direction. There are 3 normal strain components:

$$\epsilon_{11} = \frac{\partial u_1}{\partial x_1}, \quad \epsilon_{22} = \frac{\partial u_2}{\partial x_2}, \quad \epsilon_{33} = \frac{\partial u_3}{\partial x_3}$$

For uniaxial stretching of a body with constant cross-sectional area (constant stress), we can write

$$\epsilon = \frac{\Delta L}{L_0}$$

ΔL = change in length

L_0 = original length

Normal strains are positive when the material length is increased, and negative when the material length is decreased

Small-strain (linear) elasticity

Engineering **shear** strain: **angle** change

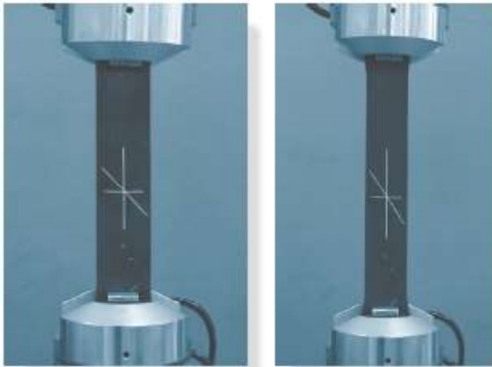

Rubber membrane subject to tension

Shear strain measures the angle change between two material line segments that were originally at 90 degrees to one another.

For example, the angle change between two material line segments originally aligned with the $x_1 - x_2$ axes can be shown to be

$$\gamma_{12} = \frac{\partial u_1}{\partial x_2} + \frac{\partial u_2}{\partial x_1}$$

Shear strains are symmetric in their indices, i.e. $\gamma_{12} = \gamma_{21}$. Therefore there are only 3 unique shear strains we need to be concerned with: $\gamma_{12}, \gamma_{23}, \gamma_{31}$

Shear strains are positive if the angle decreases (closes) and negative if the angle increases (opens)

State of stress in a body

The state of stress at a point in a solid is fully described by the three normal stresses $\sigma_x, \sigma_y,$ and σ_z and three shear stresses $\tau_{xy}, \tau_{yz},$ and τ_{xz} ; We only need three shear stress components because they are symmetric in their components as a requirement for moment equilibrium in the stress element.

- $\tau_{xy} = \tau_{yx}$
- $\tau_{yz} = \tau_{zy}$
- $\tau_{xz} = \tau_{zx}$

Using index notation, we instead write shear stresses using σ_{ij} , for example, $\tau_{xy} = \sigma_{12}$ in this notation

In index, notation, we write the stress tensor as

$$\boldsymbol{\sigma} = \begin{bmatrix} \sigma_{11} & \sigma_{12} & \sigma_{13} \\ \sigma_{21} & \sigma_{22} & \sigma_{23} \\ \sigma_{31} & \sigma_{32} & \sigma_{33} \end{bmatrix}$$

This is equivalent to writing, for a typical x-y-z system:

$$\boldsymbol{\sigma} = \begin{bmatrix} \sigma_x & \tau_{xy} & \tau_{xz} \\ \tau_{yx} & \sigma_y & \tau_{yz} \\ \tau_{zx} & \tau_{zy} & \sigma_z \end{bmatrix}$$

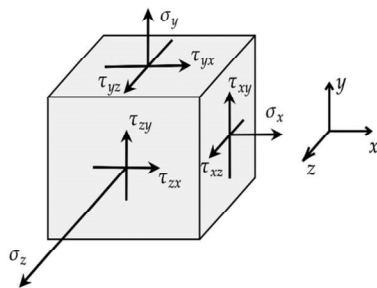

Stress-strain Relations

For **linear elastic isotropic** materials, there are 3 material properties to be aware of:

1. E = elastic modulus (Young's modulus)
2. ν = Poisson's ratio
3. G = Shear modulus

Need **only 2 constants** to describe an isotropic material because $E = 2G(1 + \nu)$

Axial loading:

Longitudinal stress-strain relation: $\sigma = E\epsilon$

Transverse strain: $\epsilon_{trans} = -\nu\epsilon_{long}$

If there are shear stresses:

$$\tau_{ij} = G\gamma_{ij} = 2G\epsilon_{ij}$$

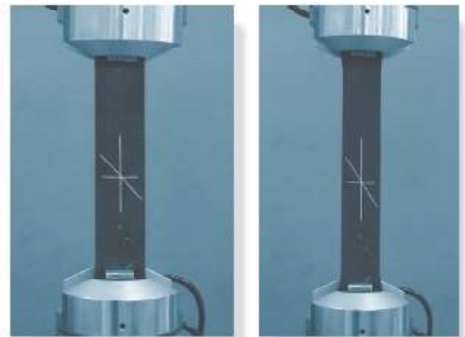

Stress-strain relations (3D Hooke's law)

In general, all six stress and strain components may be non-zero due to a complex loading of a fully 3D structure. For **any** linearly elastic material, the relationship can be written as $\{\boldsymbol{\sigma}\} = [\mathbf{C}]\{\boldsymbol{\epsilon}\}$. The formulae below are for **isotropic** materials.

$$\begin{Bmatrix} \sigma_{11} \\ \sigma_{22} \\ \sigma_{33} \\ \sigma_{12} \\ \sigma_{13} \\ \sigma_{23} \end{Bmatrix} = \frac{E}{(1+\nu)(1-2\nu)} \begin{bmatrix} 1-\nu & \nu & \nu & 0 & 0 & 0 \\ \nu & 1-\nu & \nu & 0 & 0 & 0 \\ \nu & \nu & 1-\nu & 0 & 0 & 0 \\ 0 & 0 & 0 & \frac{1-2\nu}{2} & 0 & 0 \\ 0 & 0 & 0 & 0 & \frac{1-2\nu}{2} & 0 \\ 0 & 0 & 0 & 0 & 0 & \frac{1-2\nu}{2} \end{bmatrix} \begin{Bmatrix} \epsilon_{11} \\ \epsilon_{22} \\ \epsilon_{33} \\ 2\epsilon_{12} \\ 2\epsilon_{13} \\ 2\epsilon_{23} \end{Bmatrix}$$

We can also invert the relationship to write $\{\boldsymbol{\epsilon}\} = [\mathbf{C}]^{-1}\{\boldsymbol{\sigma}\}$

$$\begin{Bmatrix} \epsilon_{11} \\ \epsilon_{22} \\ \epsilon_{33} \\ 2\epsilon_{12} \\ 2\epsilon_{13} \\ 2\epsilon_{23} \end{Bmatrix} = \frac{1}{E} \begin{bmatrix} 1 & -\nu & -\nu & 0 & 0 & 0 \\ -\nu & 1 & -\nu & 0 & 0 & 0 \\ -\nu & -\nu & 1 & 0 & 0 & 0 \\ 0 & 0 & 0 & 2+2\nu & 0 & 0 \\ 0 & 0 & 0 & 0 & 2+2\nu & 0 \\ 0 & 0 & 0 & 0 & 0 & 2+2\nu \end{bmatrix} \begin{Bmatrix} \sigma_{11} \\ \sigma_{22} \\ \sigma_{33} \\ \sigma_{12} \\ \sigma_{13} \\ \sigma_{23} \end{Bmatrix}$$

Plane Strain

- In the plane strain case, only in-plane strain components are non-zero:

$$\boldsymbol{\epsilon} = \begin{bmatrix} \epsilon_{11} & \epsilon_{12} & 0 \\ \epsilon_{12} & \epsilon_{22} & 0 \\ 0 & 0 & 0 \end{bmatrix} \quad \boldsymbol{\sigma} = \begin{bmatrix} \sigma_{11} & \sigma_{12} & 0 \\ \sigma_{21} & \sigma_{22} & 0 \\ 0 & 0 & \sigma_{33} \end{bmatrix}$$

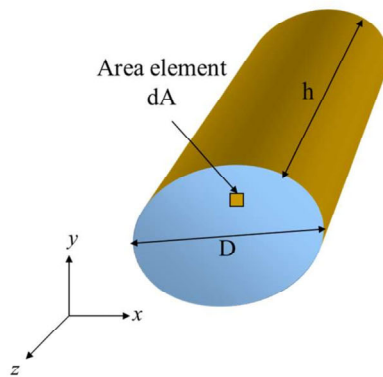

Assumptions:

- $h \gg D$
- No body forces or tractions in the out-of-plane (z) direction
- Applied tractions do not vary in the out-of-plane (z) direction

Plane Strain

Examples of plane strain problems

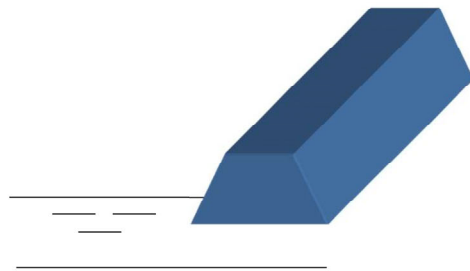

Dam

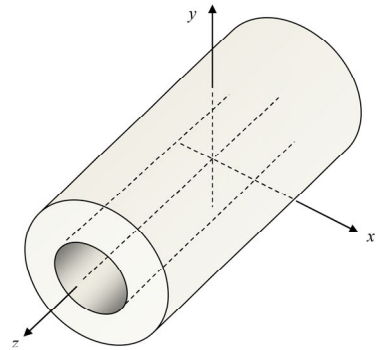

**Long cylinders
under uniform loading**

Plane Stress

- In the plane stress case, only in-plane stress components are non-zero:

$$\boldsymbol{\sigma} = \begin{bmatrix} \sigma_{11} & \sigma_{12} & 0 \\ \sigma_{21} & \sigma_{22} & 0 \\ 0 & 0 & 0 \end{bmatrix}$$

$$\boldsymbol{\epsilon} = \begin{bmatrix} \epsilon_{11} & \epsilon_{12} & 0 \\ \epsilon_{21} & \epsilon_{22} & 0 \\ 0 & 0 & \epsilon_{33} \end{bmatrix}$$

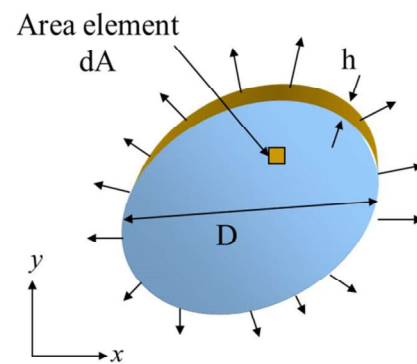

Assumptions:

- $h \ll D$
- Out-of-plane (z) surfaces are traction-free
- No loads applied in the z direction

Plane Stress

Examples of plane stress problems

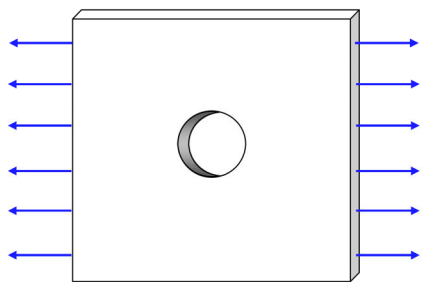

Thin plate with central hole

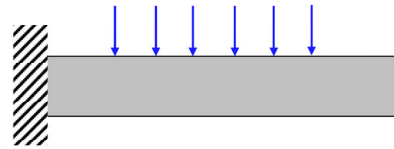

Thin cantilever plate

Post-processing

- **Principal stresses:** max/min normal stresses on any plane
- **Von Mises stress:** Useful for evaluating safety factor on ductile materials; plastic yield is predicted when the von Mises stress exceeds the yield strength of the material

In two dimensions:

$$\sigma_{p1,p2} = \frac{\sigma_{11} + \sigma_{22}}{2} \pm \sqrt{\left(\frac{\sigma_{11} - \sigma_{22}}{2}\right)^2 + (\sigma_{12})^2}$$

Plane Stress: $\sigma_{p3} = 0$

Plane Strain: $\sigma_{p3} = \sigma_{33} = \frac{E \nu}{(1 + \nu)(1 - 2\nu)} (\epsilon_{11} + \epsilon_{22})$

Von Mises Stress

$$\sigma_{VM} = \sqrt{\frac{1}{2} [(\sigma_{p1} - \sigma_{p2})^2 + (\sigma_{p1} - \sigma_{p3})^2 + (\sigma_{p3} - \sigma_{p2})^2]}$$