

# Physics 524 Week 9 Homework Exercises

Due: Tuesday 10/29/2024 at noon

## Due date reminder, etc.

Please email your completed assignment to the course TA by Tuesday of next week before class.

Your homework submissions—code, cell phone photos, etc. must include enough identifying information for us to tell who you are!

## Section 2: Problem (1)

A core processor chip in a PC dissipates 100W of heat. The user has attached a liquid-channel cooling block directly to it, through which coolant liquid can flow.

The user has a choice between water or a non-conductive modern liquid coolant with GWP=0 (3M NOVEC®649). What is the mass flow  $\dot{m}$  of (1) water and (2) 3M NOVEC®649 needed to ensure that the coolant liquid temperature rise  $\Delta T$  is limited to 10°C?

In practice of course, heat must be channelled into the cooling fluid. To do this it must flow through the thickness of the core processor chip silicon package, through the adhesive or thermal grease that bonds it to the cooling block and through the wall of the cooling block into the fluid. All these materials have thermal resistances which add up, resulting in the silicon chip operating at a higher temperature than the cooling fluid circulating through the block. We will revisit this later.

## Section 2: Problem (2)

A core processor chip in a PC dissipates 100W of heat. The chip has a (4 cm x 4 cm) square profile. The user has attached a (4 cm x 4 cm) square channelled copper block on top of it, through which coolant liquid can flow to cool the processor. The cooling block makes contact with a thin metal jacket on top of the chip through a 100 micron layer of Dow Corning 340 thermally-conducting grease .

The processor chip package itself is 3 mm thick in total (as illustrated in the figure), made from a 1 mm-thick active silicon layer that is centrally-sandwiched with 1 mm of ceramic encapsulant above and below it. The ceramic fill has a thermal conductivity of  $200 \text{ Wm}^{-1}\cdot\text{K}^{-1}$ .

**Note:** In this simplified thermal model the heat is dissipated in the doped semiconductor implanted into the surface of the active silicon layer *facing down* towards the connector to the mother board, and must pass through 1 mm of active silicon substrate in the opposite (up) direction on its way to the cooling block. Any heat loss by conduction through the connector pins to the mother board can be ignored. The

very small thermal resistance of the thin topside metal jacket can also be neglected in the calculation; you can pretend that it isn't there.

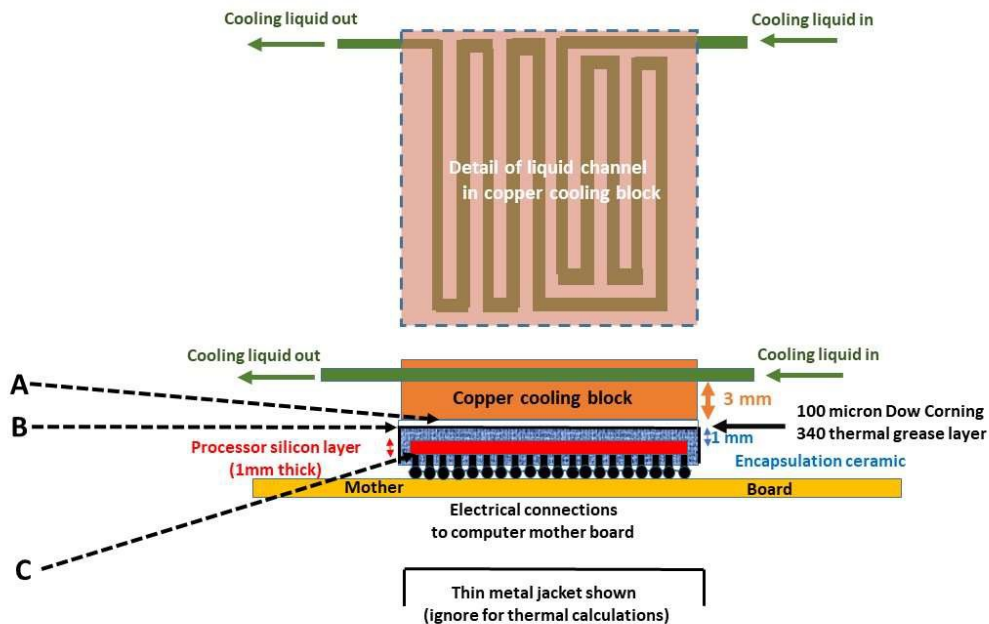

*Thermal paths in the cooling of a silicon processor chip (local channel)*

The heat from the chip can therefore be thought of as passing through 1 mm of active silicon and a further 1 mm of ceramic before passing through a 100 micron (0.1mm) thick layer of Dow Corning 340 thermal paste, and finally through the copper cooling block with an effective thickness of 3 mm before reaching the cooling liquid channel, as shown in the figure.

Coolant enters the cooling block and follows a tortious path to try to extract heat as uniformly as possible. The high transverse thermal conductivity of the copper block helps spread the heat transversely over the whole (4 cm x 4 cm) between the wiggles of the coolant channel.

**Problem (2) questions:**

For the first 4 questions you can consider that the coolant to enters the block 20°C and leaves at 30°C. The average temperature in the copper block cooling channel can be taken as 25°C.

What are the (progressively-increasing) temperatures on the following surfaces.

- The surface of the copper block in contact with the top face of the Dow Corning 340 thermal grease film (**A**)? (This is 3mm from the plane of the coolant channel)
  - The surface of the ceramic in contact with the bottom face of the 100 micron Dow Corning 340 thermal grease film (**B**)?
  - The hot (down facing) side of the 1 mm thick processor chip itself (**C**)?
- Note:** you have to consider the thermal resistance of two materials in series to get to this figure.
- Which material contributes the biggest temperature difference (temperature difference

- across itself)?
- What method would you use to reduce the contribution of this layer (mechanical solutions acceptable)?

Building on this knowledge...

The user has a choice between water or a non-conductive modern liquid coolant with GWP = 0 (3M NOVEC® 649), but the pump available can only circulate a maximum of 3 grams per second (a mass flow of 0.003 kg/s) of any liquid. What is the input temperature of NOVEC 649 to the copper cooling block to maintain an average temperature in the block cooling channel of 25°C? (Hint: this calculation uses the concept of coolant heat capacity and mass flow from the previous problem.

### Section 3 problem (1)

## ATLAS Si tracker thermosiphon $C_3F_8$ condenser

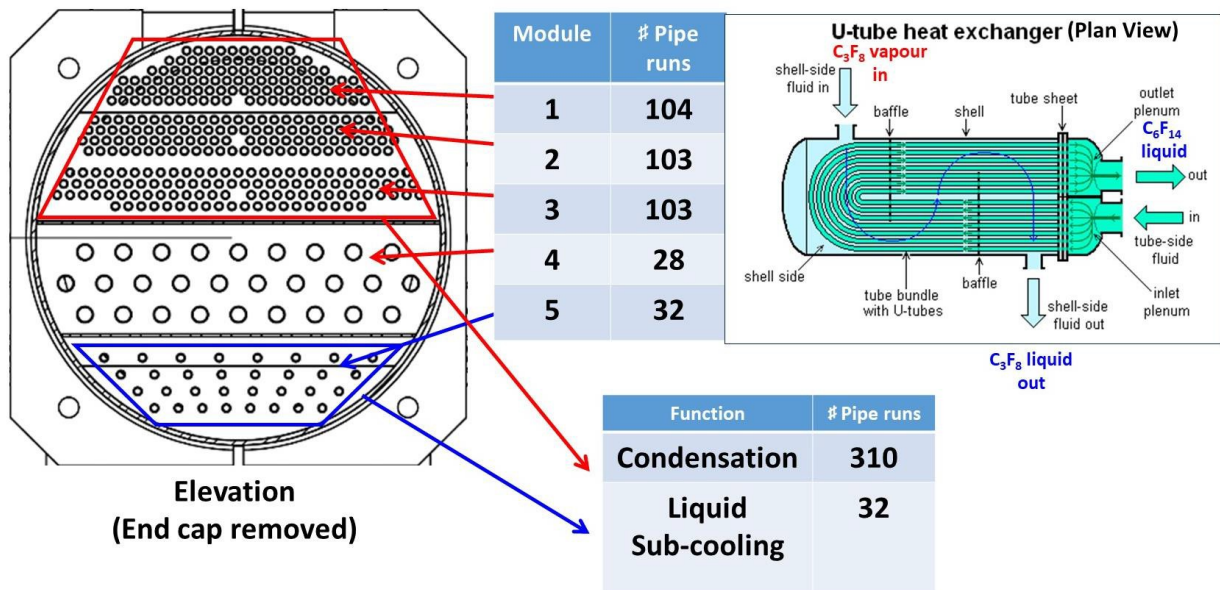

\* Liquid  $C_6F_{14}$  is used to condense  $C_3F_8$  vapor at around  $-60^\circ C$

From the figure above it was clear that a large number of tubes are needed to condense approximately 1.2 kg/s of  $C_3F_8$  to cool the ATLAS silicon tracker. This implies that a high mass flow of  $C_6F_{14}$  liquid is needed, but what is this mass flow (kg/s)?

Hints to solve this problem:

- Looking at the figure below we see that considerable thermal energy has to be extracted from the  $C_3F_8$  vapor (in the condenser) to reduce its temperature from around  $20^\circ C$  (the temperature acquired in traveling through more than 92 meters of pipes to the condenser) to  $-60^\circ C$ , where phase change can occur under the “dome”.
- Some of this heat is extracted from the vapor at a  $C_3F_8$  pressure of 320 mbar within the condenser itself (using a counter-flow of cold  $C_6F_{14}$ ), cooling the vapor from  $-25^\circ C$  (point C) to  $-60^\circ C$  before the vapor begins to condense at the saturated vapour boundary of the dome.
- Moving left from the saturated vapour boundary of the dome all energy goes into condensing the  $C_3F_8$ .
- You should therefore use the entire CD enthalpy difference in your calculation, and only this
- The specific heat capacity of  $C_6F_{14}$  in the range ( $-60^\circ C$ ,  $-65^\circ C$ ) is around  $925 J/kg$ .
- $C_6F_{14}$  remains a liquid and does not change phase during this process, but heats up by  $5^\circ C$ .

