

Measuring of small AC signals using lock-in amplifiers.



- ✓ Narrow band selective amplifiers + amplitude detector.
- ✓ Lock-in amplifiers

Lock-in amplifier technique

Simplified block diagram of a lock-in amplifier

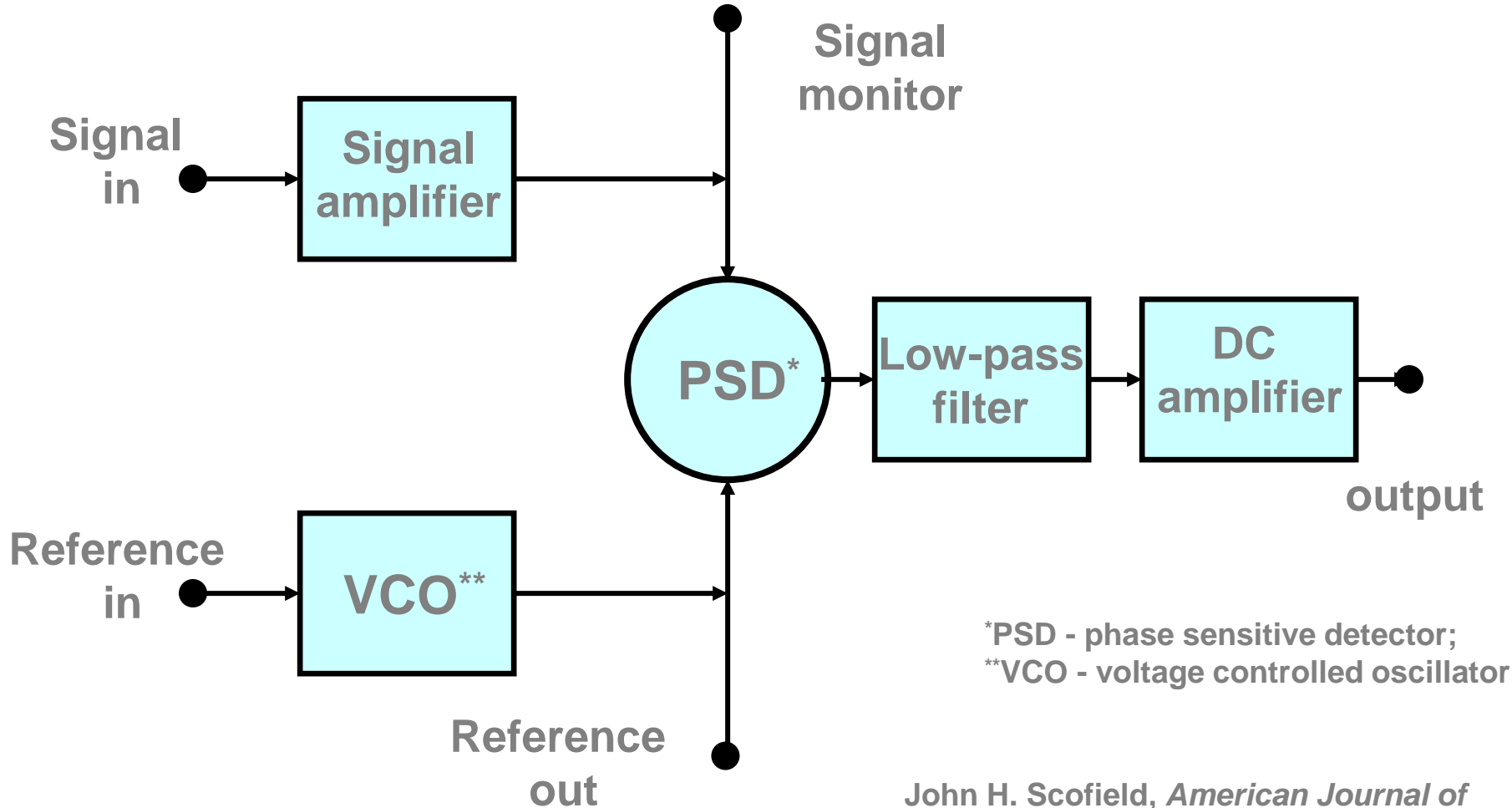

*PSD - phase sensitive detector;
**VCO - voltage controlled oscillator

John H. Scofield, *American Journal of Physics* 62 (2) 129-133 (Feb. 1994).

Lock-in amplifier. How it works.

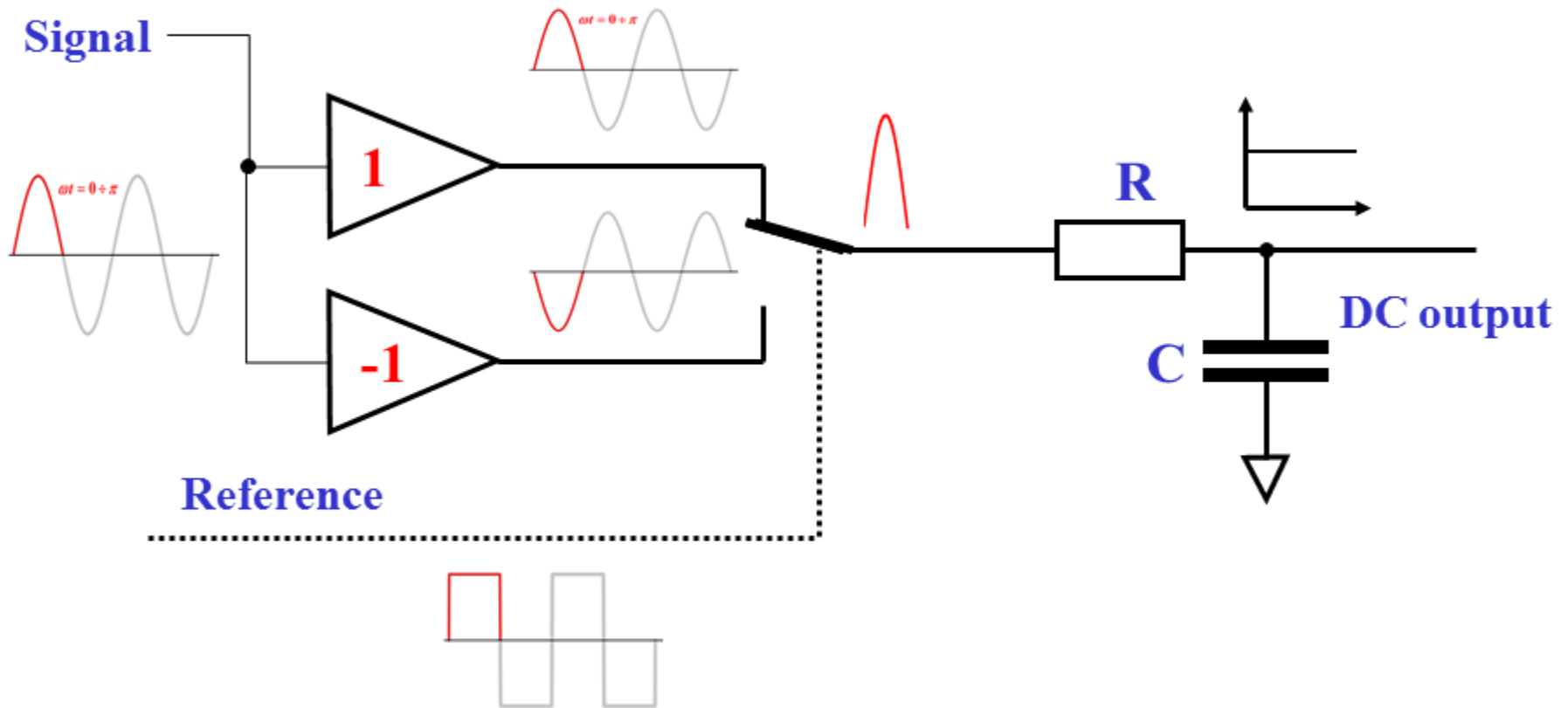

Lock-in amplifier technique

Phase shift

$$\phi = \pi/4, V_{\text{out}} = 0.72V_{\text{in}}$$

$$V_{\text{in}} = \sin(\omega t + \pi/4)$$

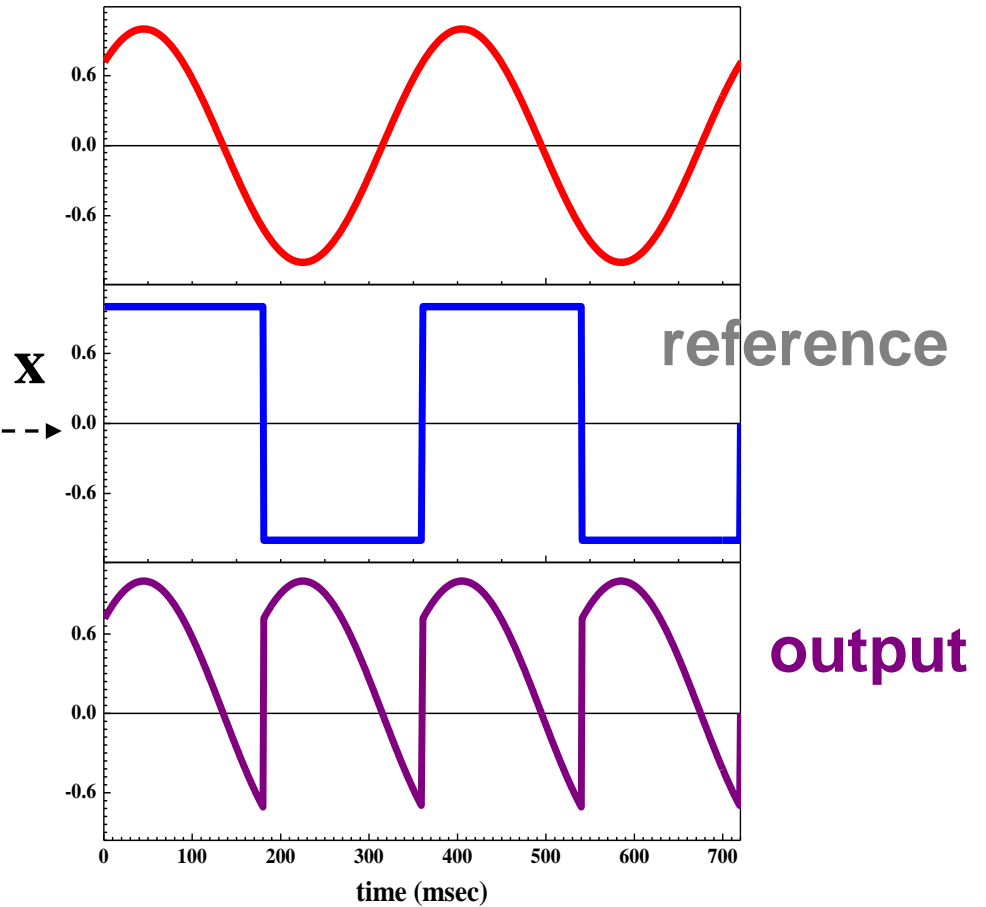
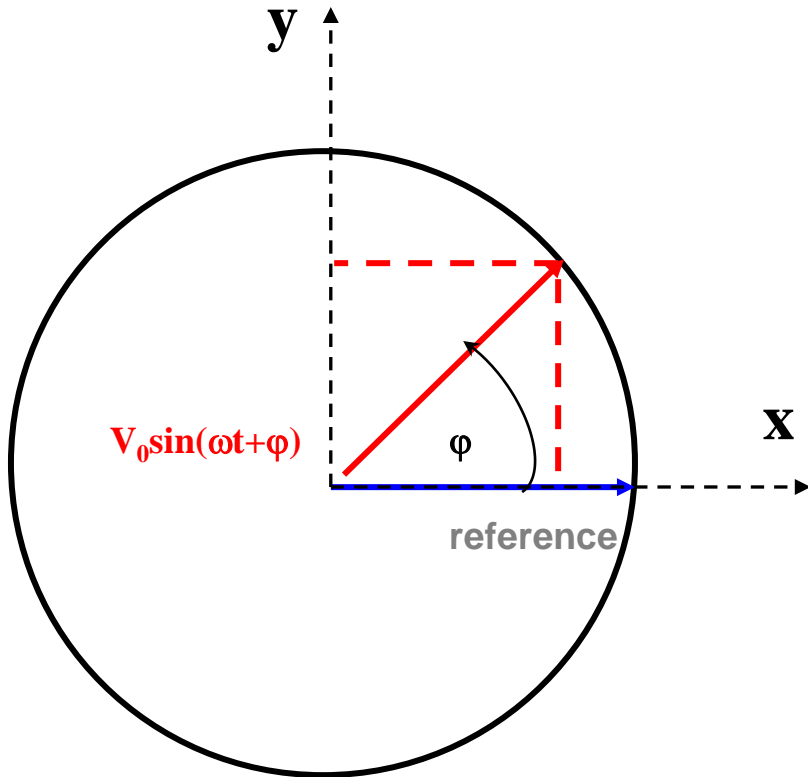

Lock-in amplifier technique

Phase shift

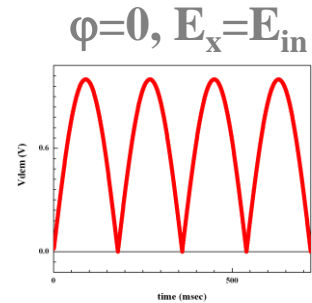
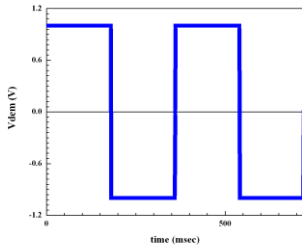
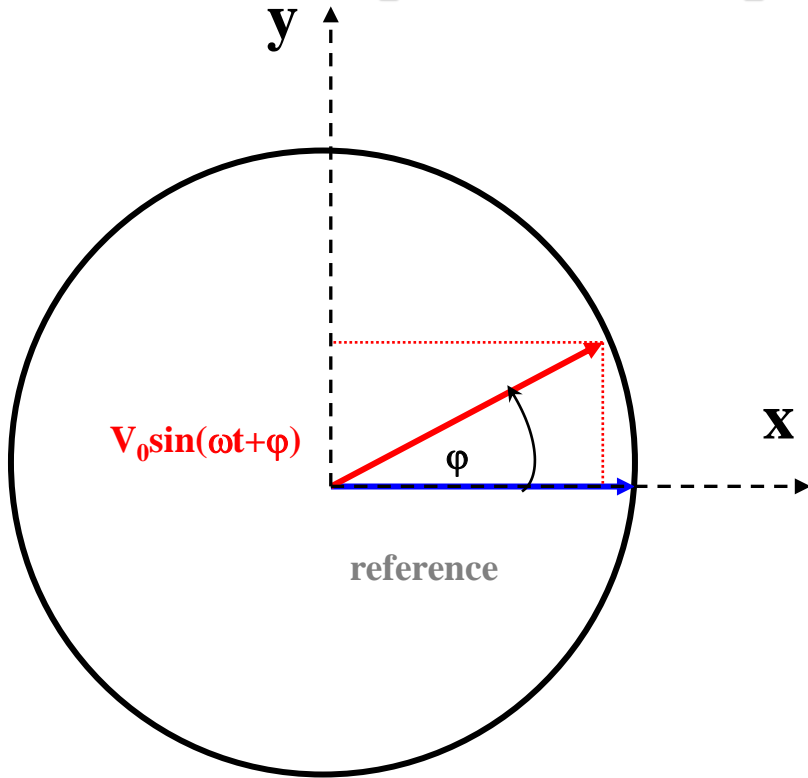

The dependence of pattern of the output signal after demodulator on phase shift between input and reference signals

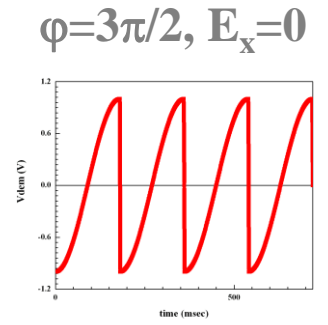
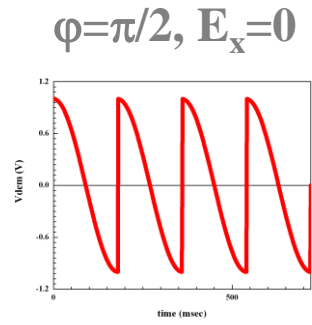
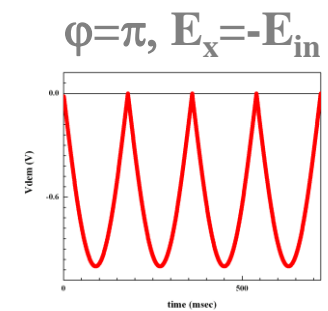
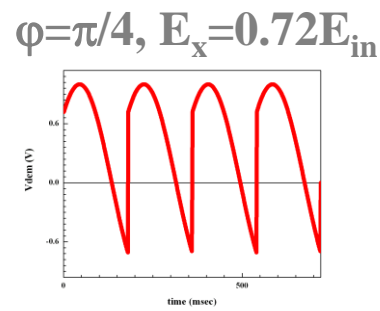

Lock-in amplifier technique. Simple math.

$$U_x = U_{x0} \sin(\omega_1 t + \theta_1) \quad \text{- input signal}$$

$$U_r = \sin(\omega_2 t + \theta_2) \quad \text{- reference signal}$$

$$U_{de\ mod} = U_x \cdot U_r = U_{x0} \sin(\omega_1 t + \theta_1) \cdot \sin(\omega_2 t + \theta_2) =$$

$$\frac{U_{x0}}{2} [\cos((\omega_1 + \omega_2)t + \theta_1 + \theta_2) + \cos((\omega_1 - \omega_2)t + \theta_1 - \theta_2)]$$

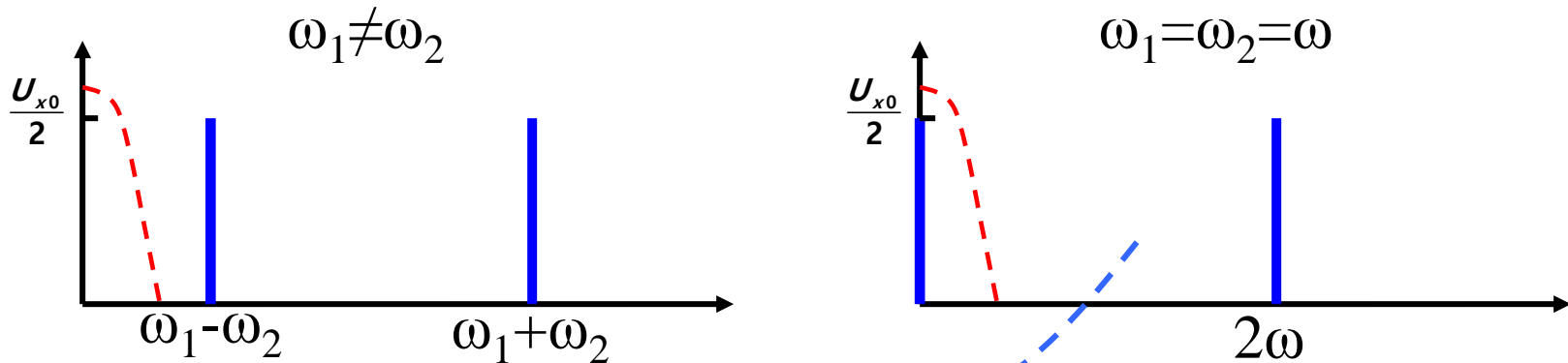

$$U_{de\ mod} = \frac{U_{x0}}{2} [\cos(2\omega t + \theta_1 + \theta_2) + \cos(\theta_1 - \theta_2)]$$

and after low-pass filtering \longrightarrow $U_{de\ mod} = \frac{U_{x0}}{2} \cos(\theta_1 - \theta_2)$

Lock-in amplifier technique

Two channels demodulation

In many technical applications we need to measure both components (E_x , E_y) of the input signal. To do this most of the modern lock-in amplifiers are equipped by two demodulators.

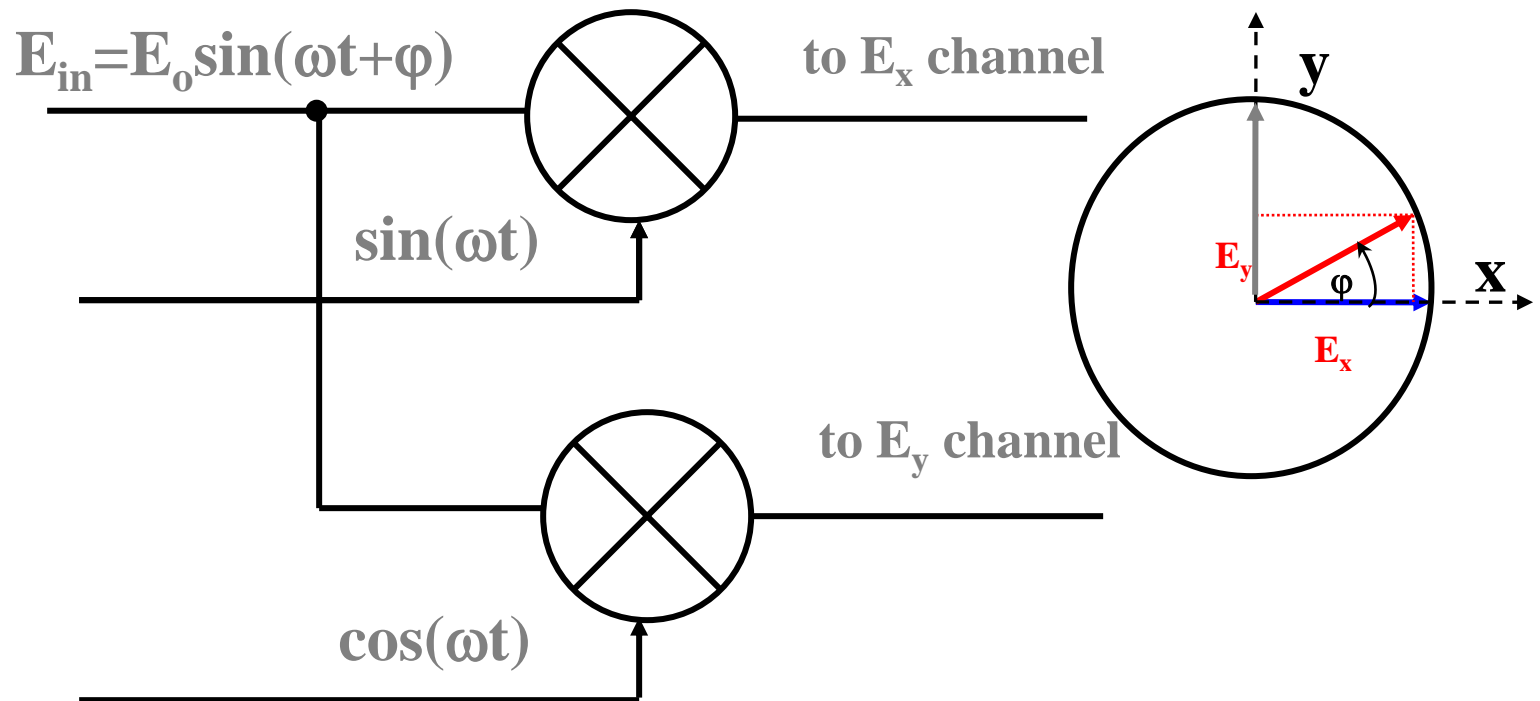

Invention of the Lock-in amplifier

In 1961, Princeton Applied Research was founded by a group of scientists from Princeton University and the Plasma Physics Laboratory. With a desire to establish significant improvements to research instrumentation the team developed the first commercial lock-in amplifier in 1962.



Robert Henry Dicke
1916-1997



Model HR-8

f range: = 5Hz÷150kHz

Lock-in amplifier technique

Analog and digital lock-ins



SR510 & SR530 Lock-In Amplifiers

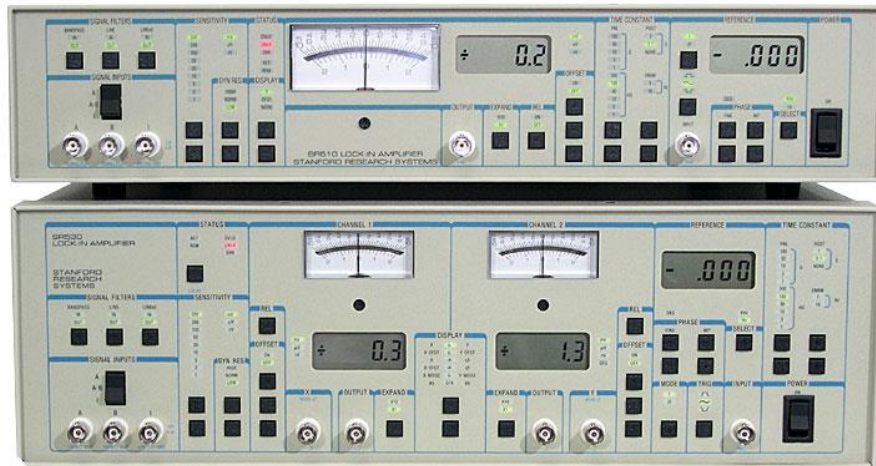

- 0.5 Hz to 100 kHz frequency range
- Current and voltage inputs
- Up to 80 dB dynamic reserve
- Tracking band-pass and line filters
- Internal reference oscillator
- Four ADC inputs, two DAC outputs
- GPIB and RS-232 interfaces

Analog lock-ins from Stanford Research Systems

Lock-in amplifier technique

Analog lock-ins

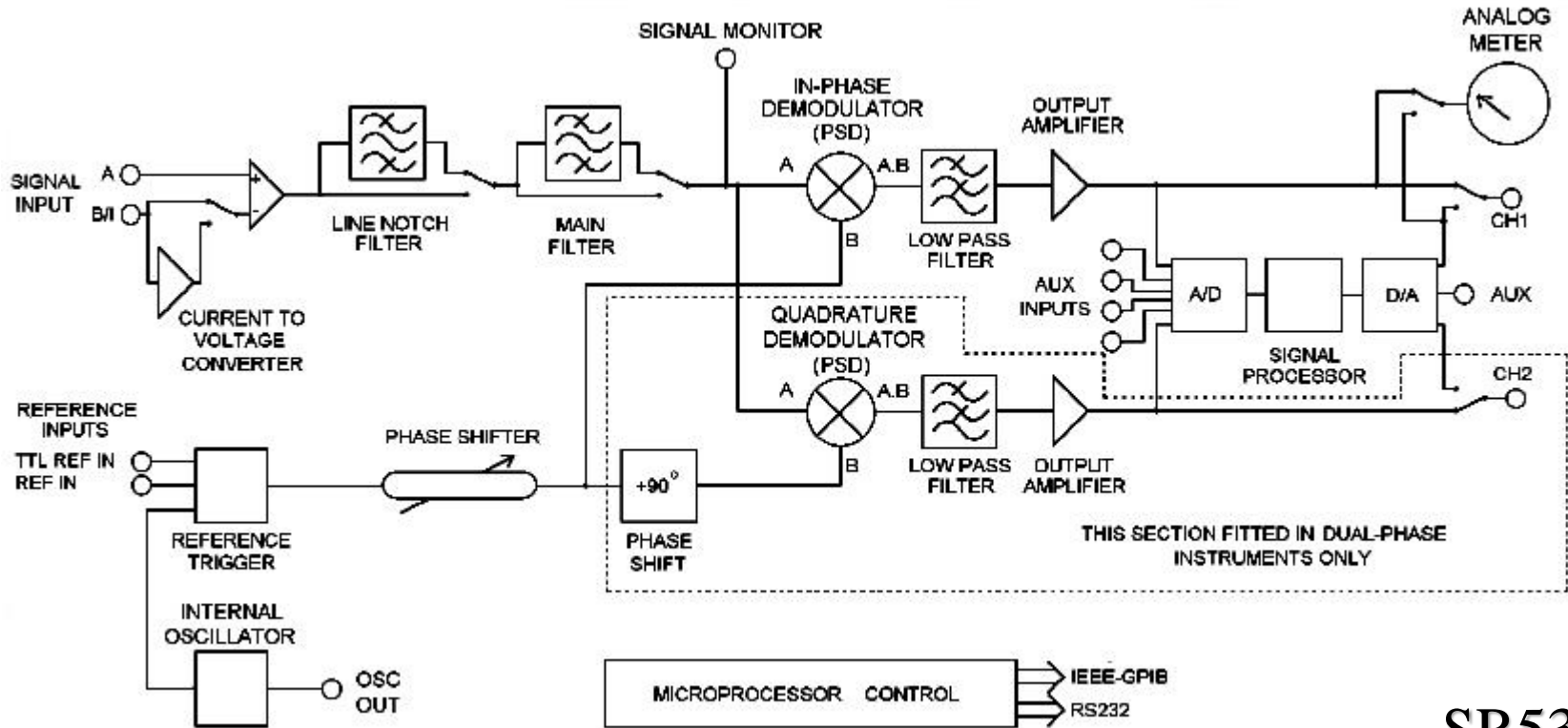

SR530

Block-diagram of analog lock-in

Lock-in amplifier technique

Analog lock-ins



SR124

- Low noise, all analog design**
- No digital interference**
- 0.2 Hz to 200 kHz measurement range**
- Low noise current and voltage inputs**
- Harmonic detection (f, 2f, or 3f)**
- Selectable input filtering**

Lock-in amplifier technique

Digital lock-ins



Two DSP lock-in amplifiers: SR830 from Stanford Research Systems and 7265 from Signal Recovery.



The main advantages of digital lock-ins:

- * high phase stability;
- * broad frequency range;
- * ideal for low and ultra low frequencies (up to 0.001Hz)
- * harmonics up to 65,536 (7265), 19,999 (SR830).

Lock-in amplifier technique

Analog and digital lock-ins

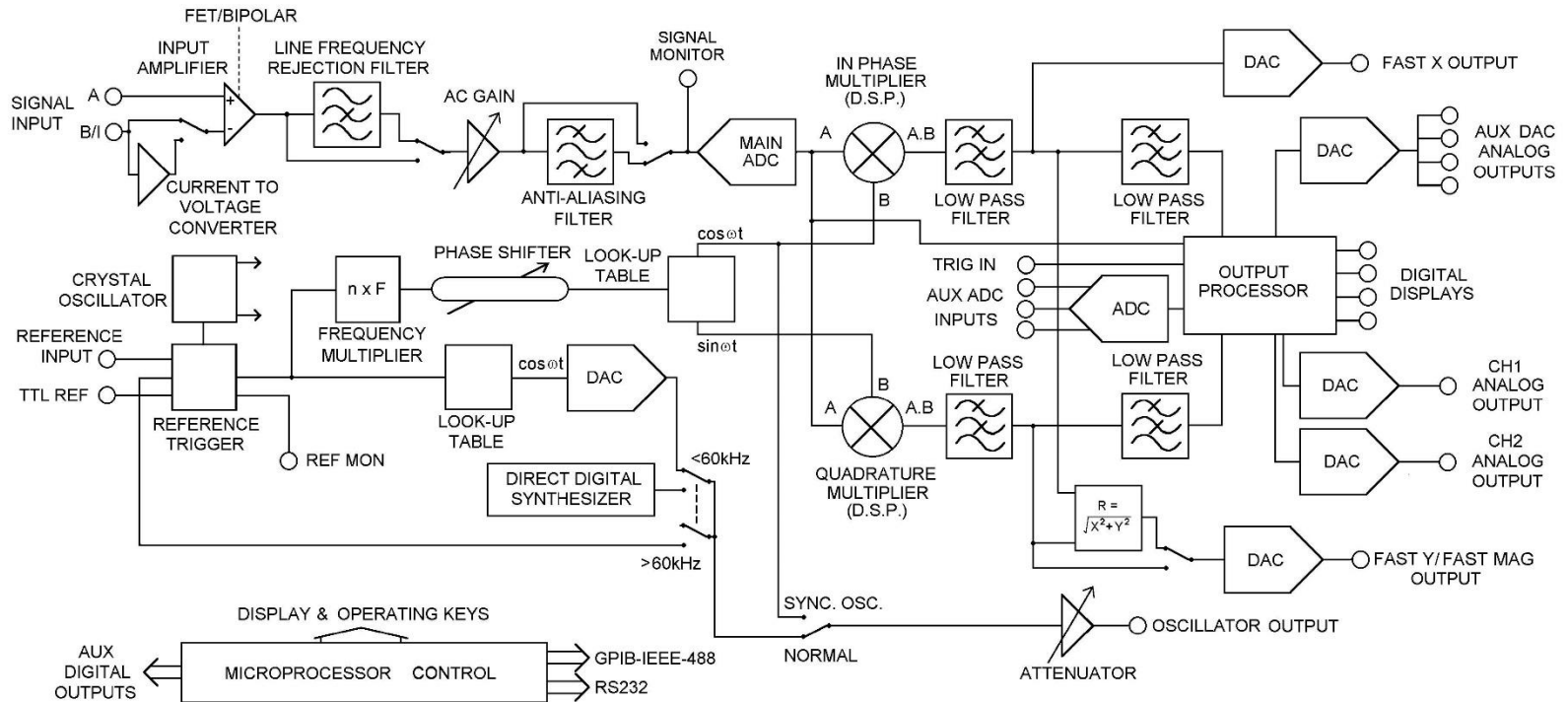

SR830

Block-diagram of digital lock-in

Lock-in amplifier technique

SR830 digital lock-ins

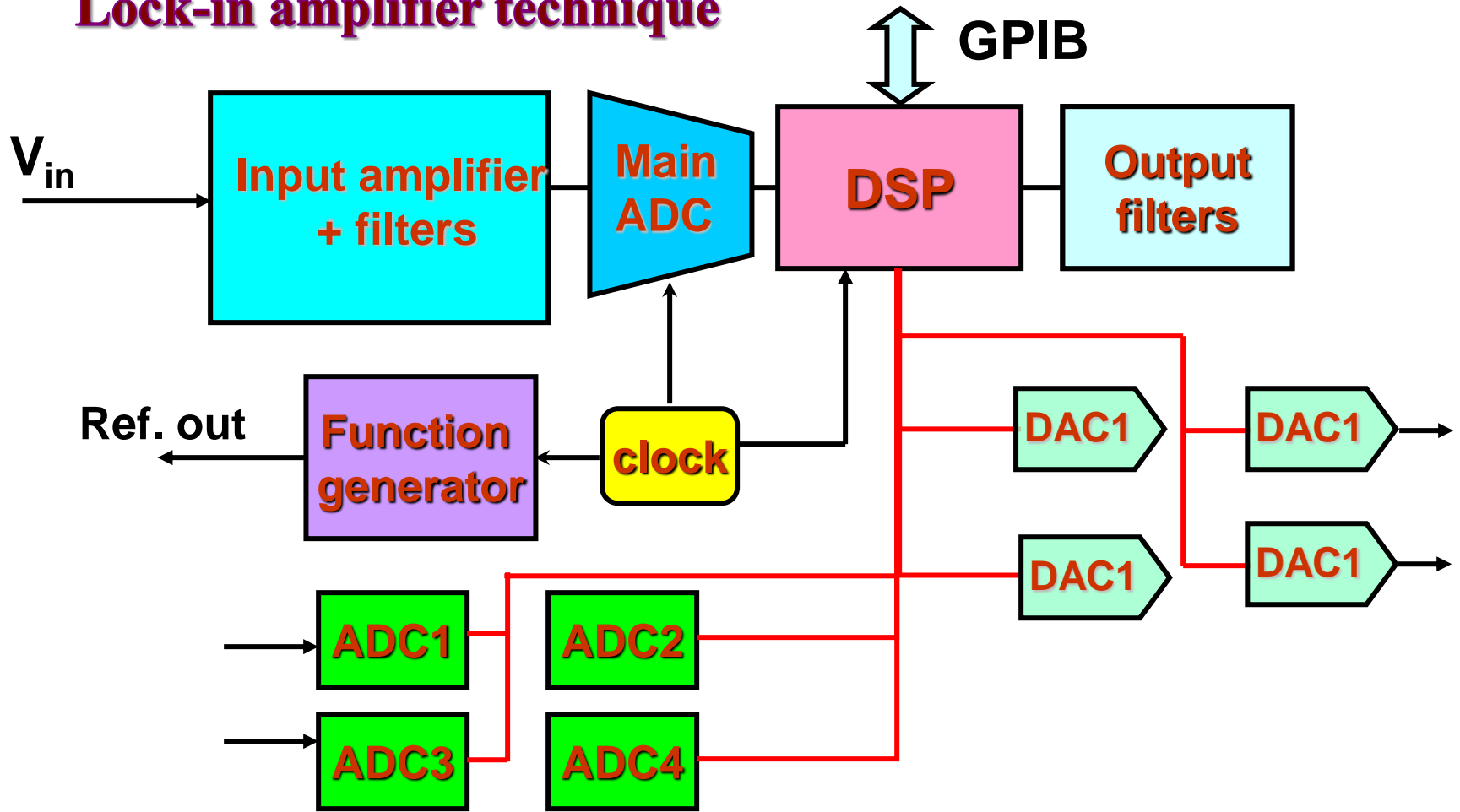

Block-diagram of digital lock-in

Lock-in amplifier technique: some applications

(i) Applying a small test signal (locked to the reference signal) to the studied object

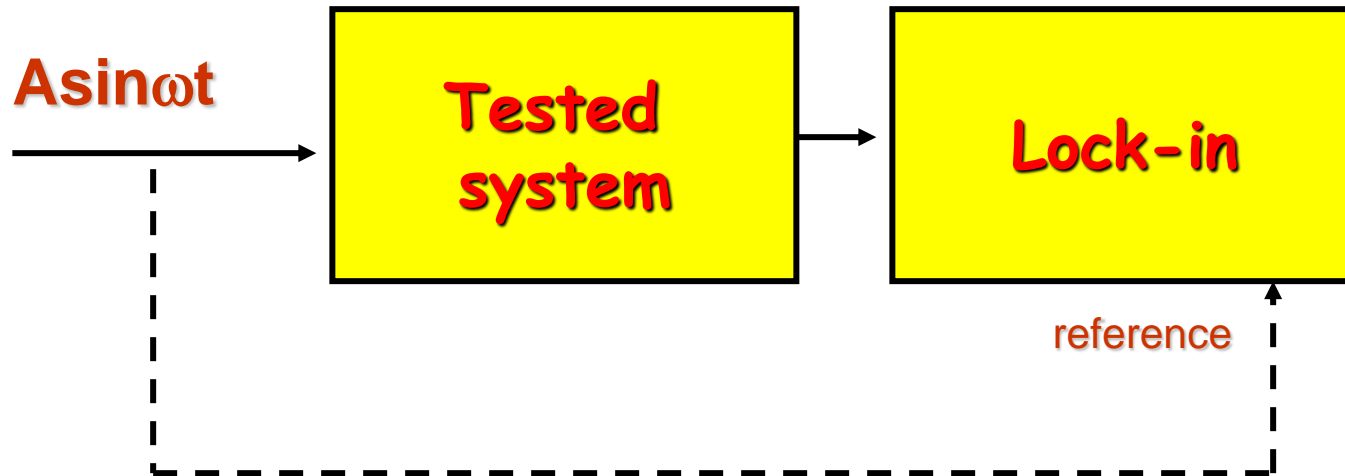

Examples: frequency domain spectroscopy (second sound), tunneling spectroscopy (analysis of the I-V curves), dielectric spectroscopy etc.

Lock-in amplifier technique: some applications

(ii) Modulating of the studied signal by the signal locked to the reference signal

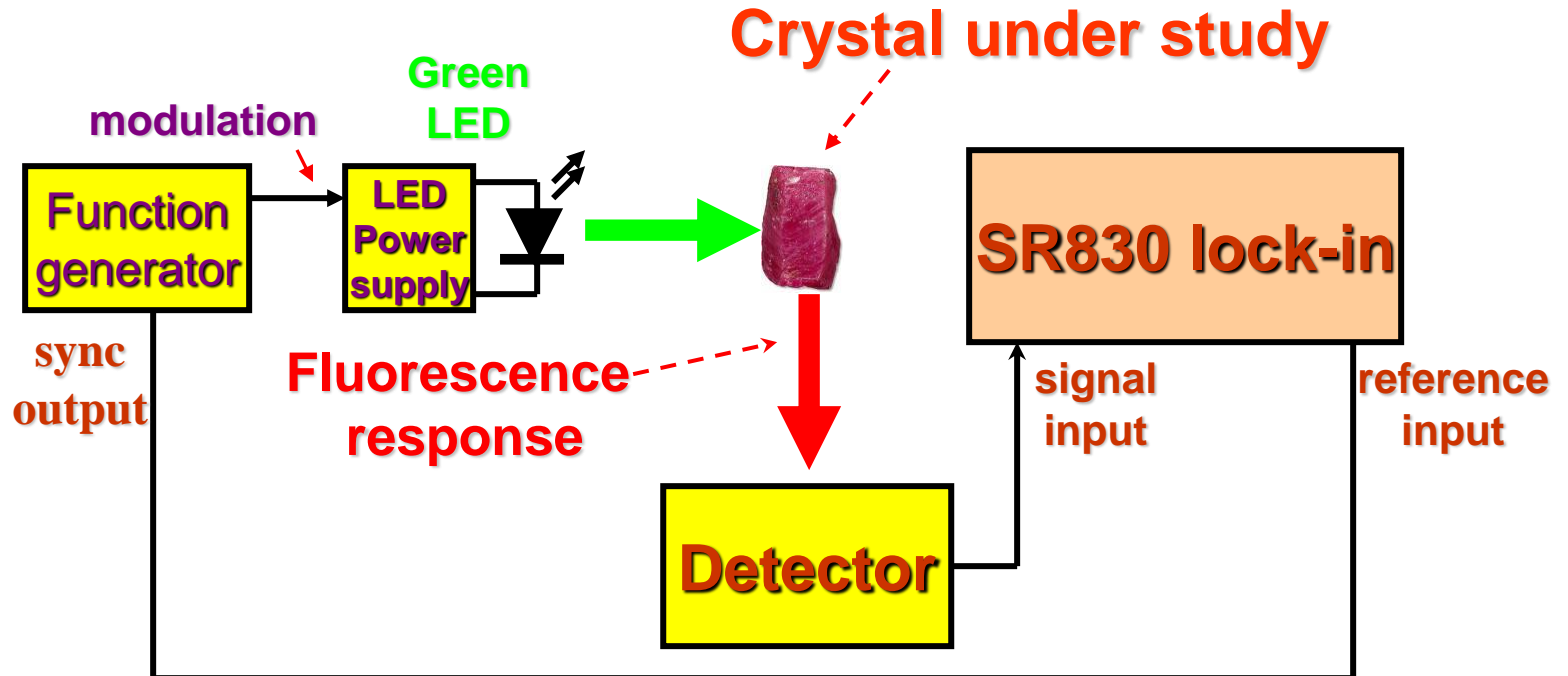

Examples: fluorescence experiment

Lock-in amplifier technique: some applications

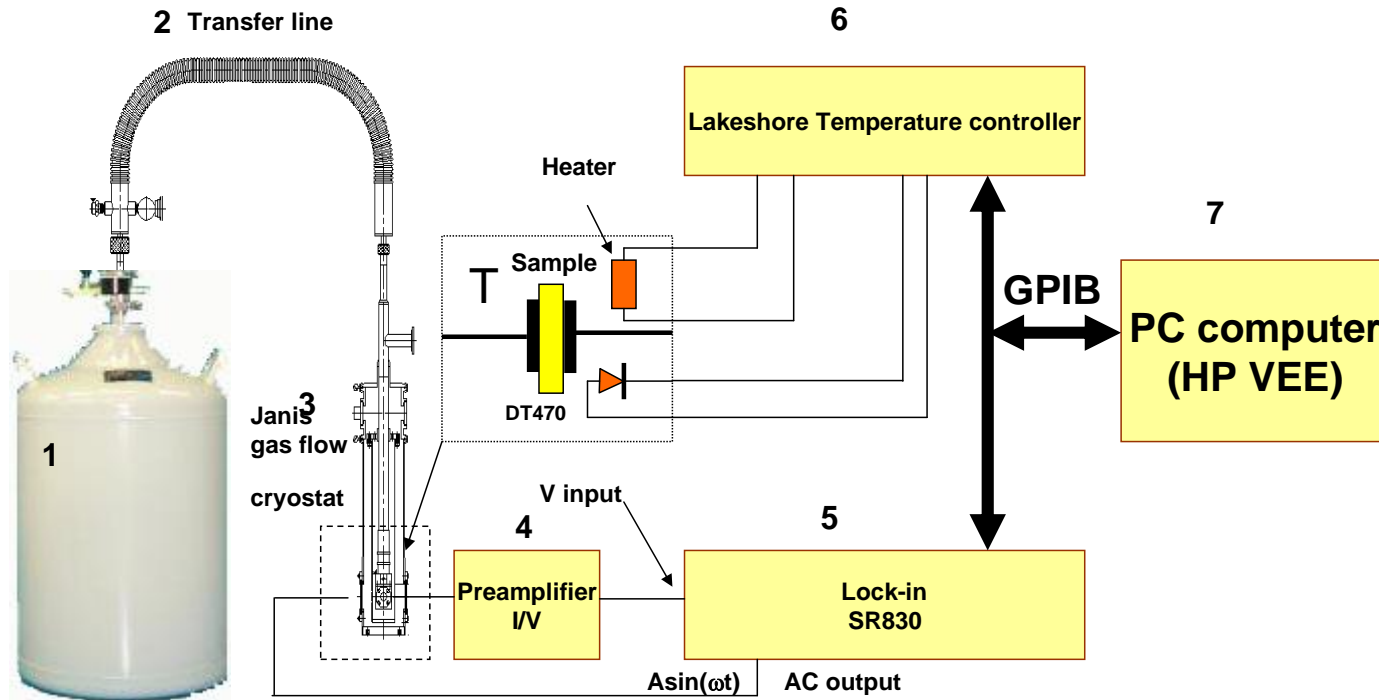

Experimental setup for measurement of the dielectric susceptibility (electrical conductivity) in the temperature range 15-450K

Lock-in amplifier technique: some applications

Scanning of the frequency of the AC signal applied to transmitter we can find the frequencies of the acoustical resonance.

Second sound experiment



Receiver

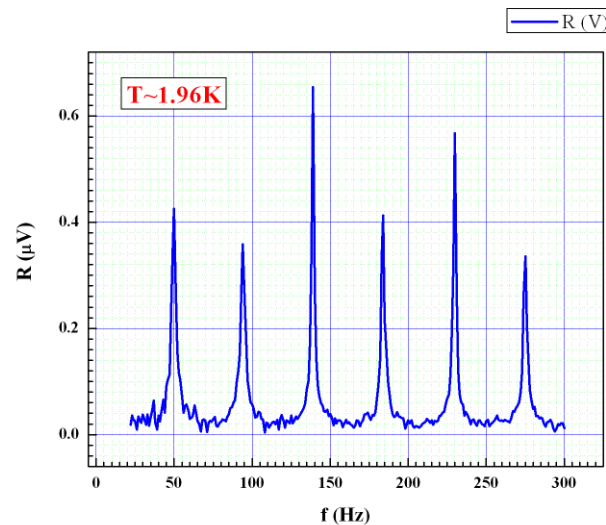
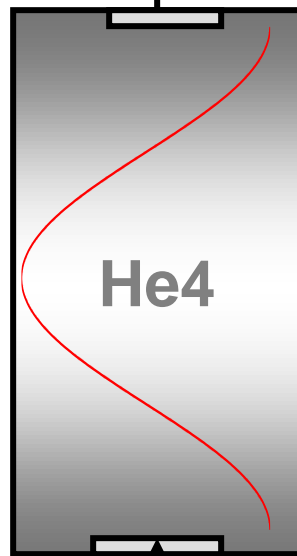

AC drive signal

Transmitter (heater)

Lock-in amplifier technique: some applications

Optical pumping

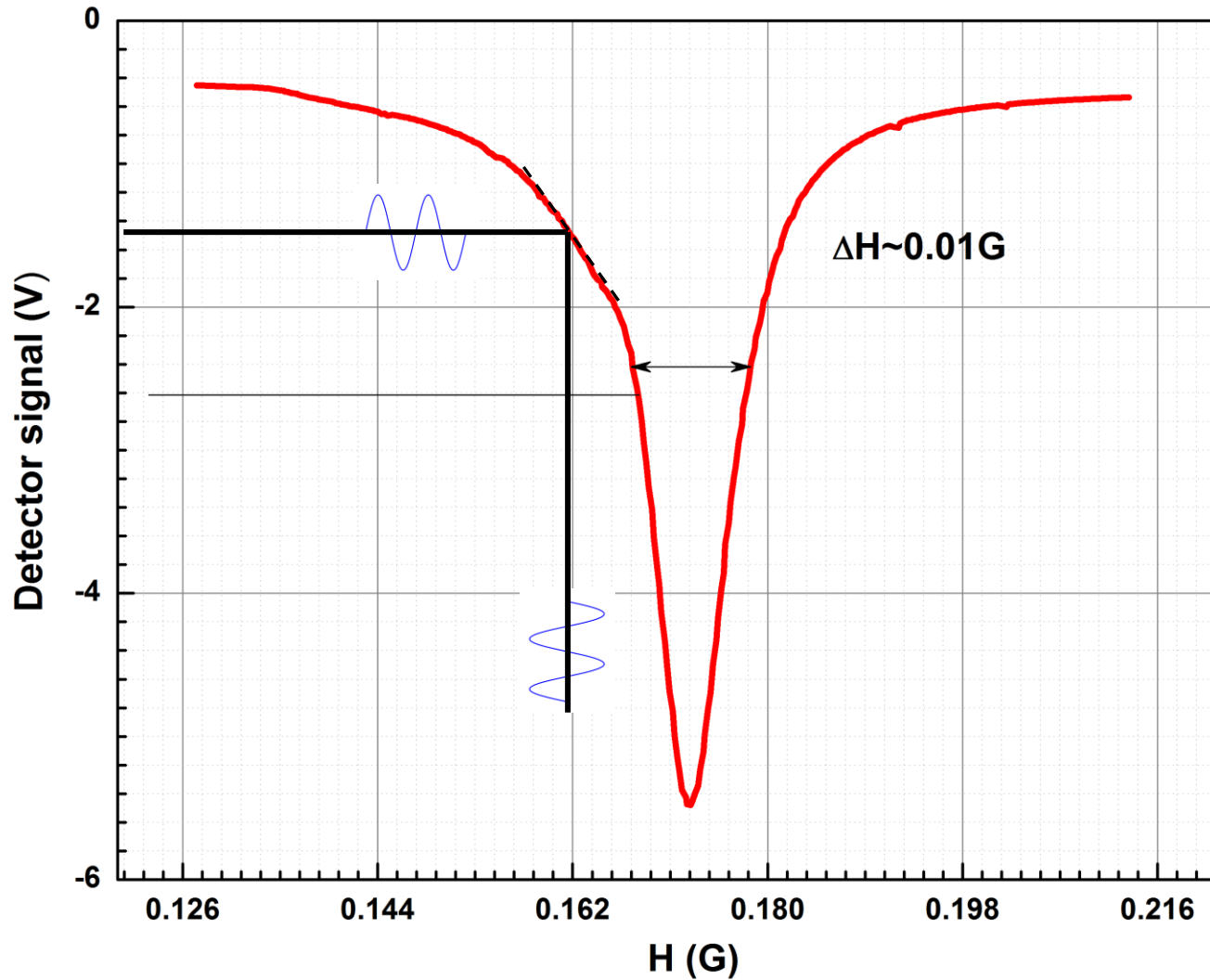

Lock-in amplifier technique: some applications

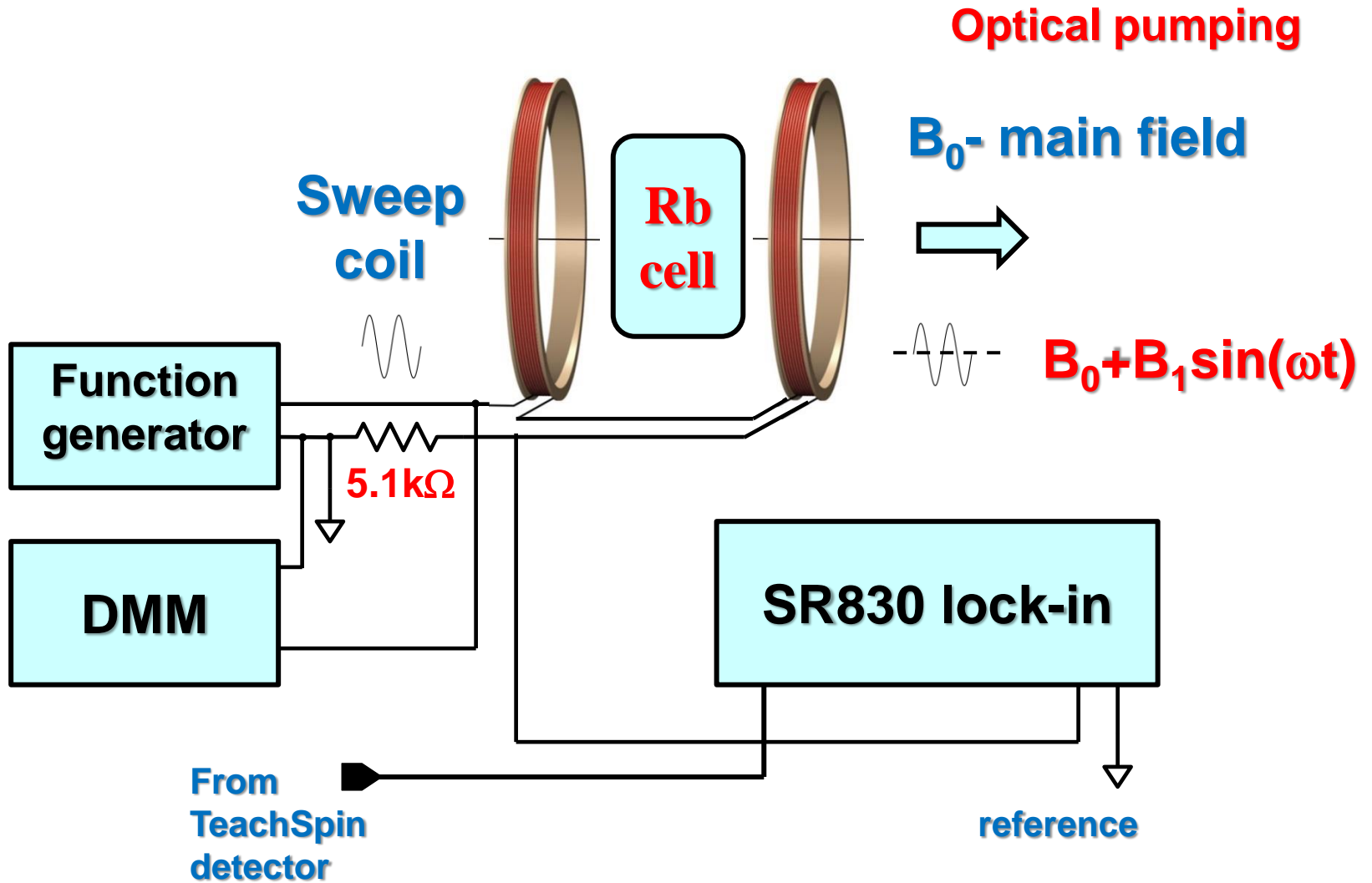

Lock-in amplifier technique: some applications

Optical pumping

The choice of
amplitude modulation

$$I_{sweep} = \frac{V_{FG}}{5.1k\Omega}$$

$$B_1 = k_{sweep} \cdot I_{sweep}$$

$$K_{sweep} \cong 0.6G/A$$

If $V_{FG} = 1V$
 $B_1 \sim 0.12mG$

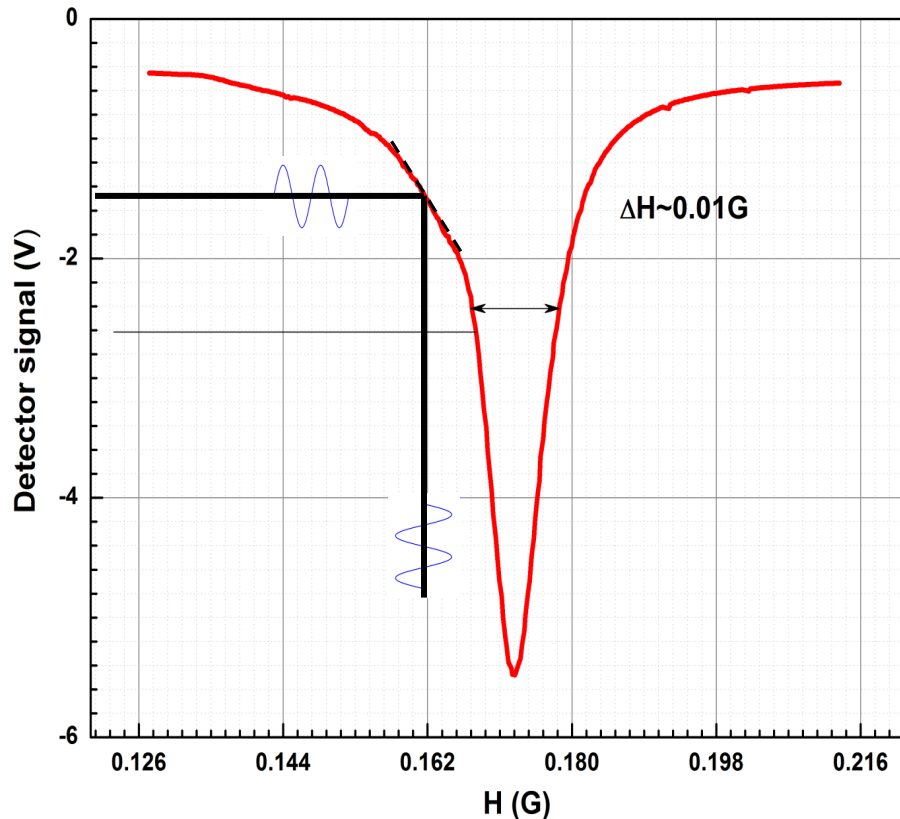

Lock-in amplifier technique: some applications

Optical pumping

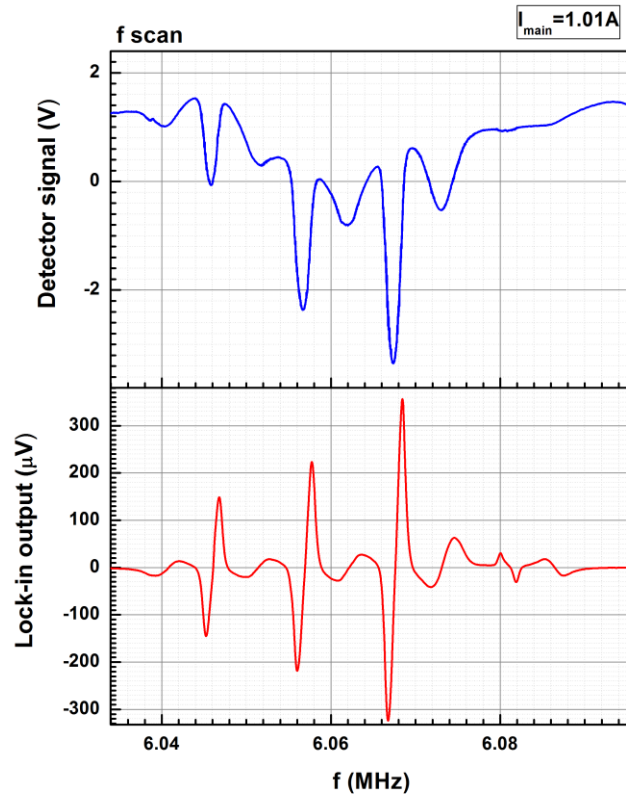

Analog detector record $I(f)$

Lock-in detector record $\frac{\partial I}{\partial H}(f)$

Mapping 0.5-2.5A from March 1st 2012: Graph6

Lock-in amplifier technique: some applications

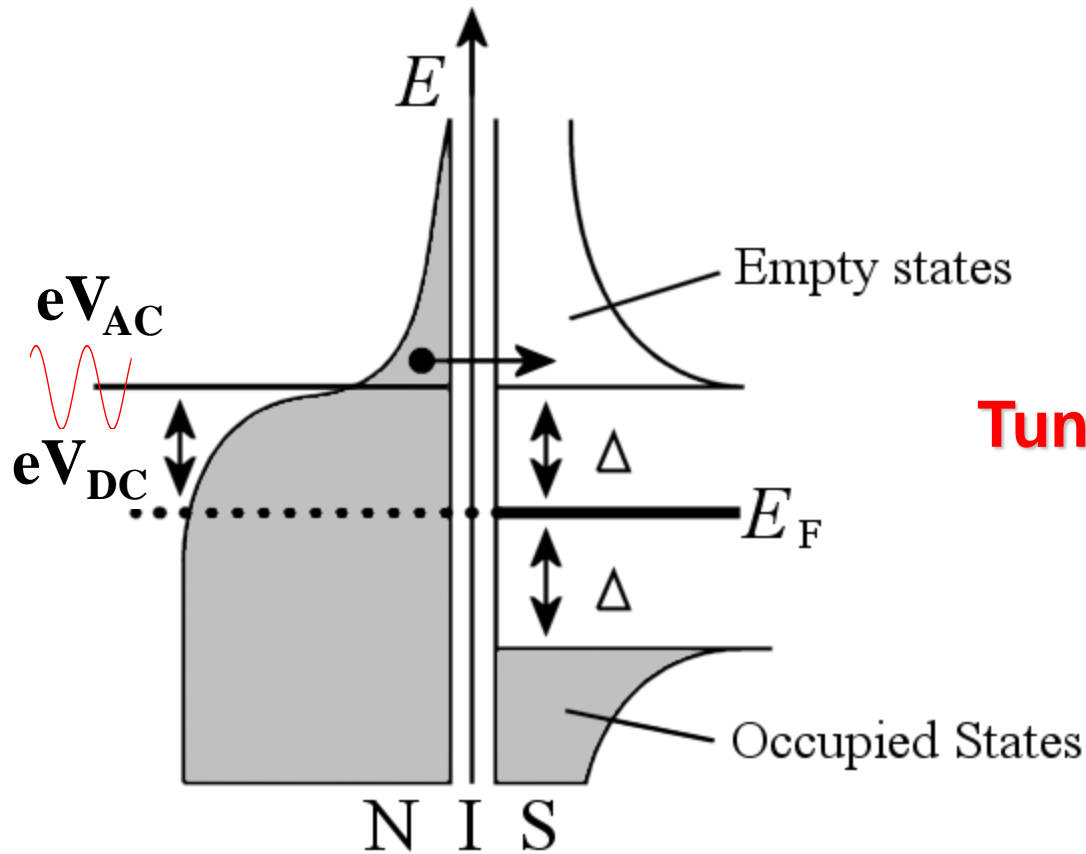

Tunneling spectroscopy

Lock-in amplifier technique: some applications

Tunneling spectroscopy

eV_{DC} only

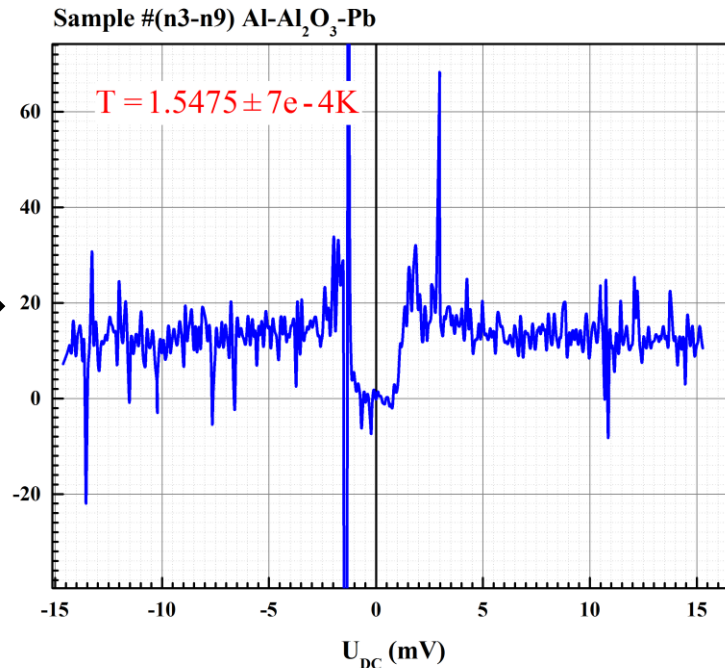
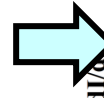
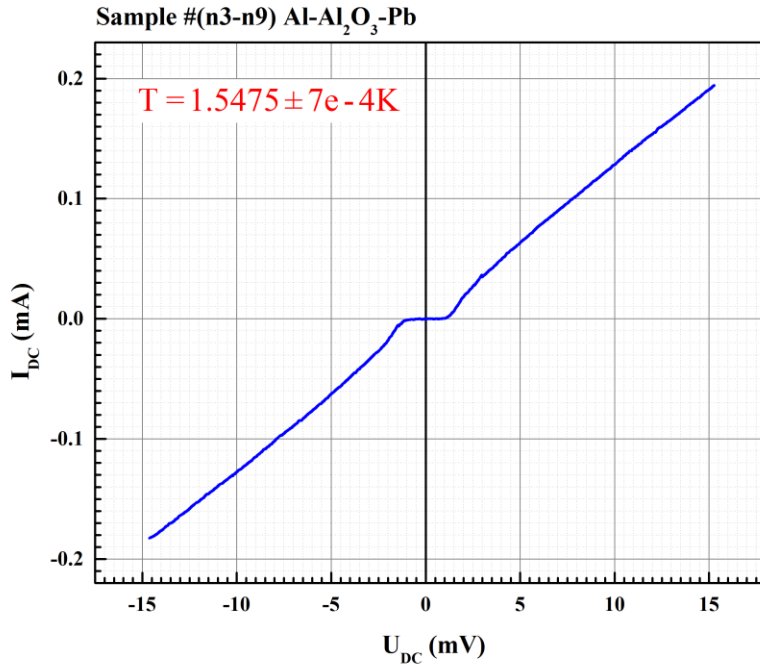

Courtesy of Anna Miller and Everett Vacek

Lock-in amplifier technique: some applications

Tunneling spectroscopy

$$eV_{DC} + eV_{AC}$$

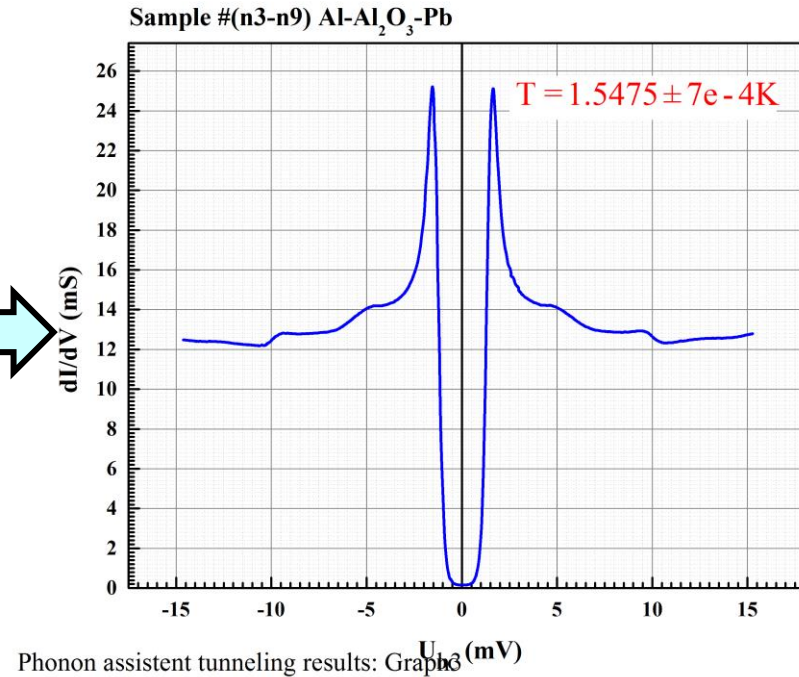
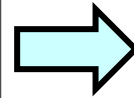
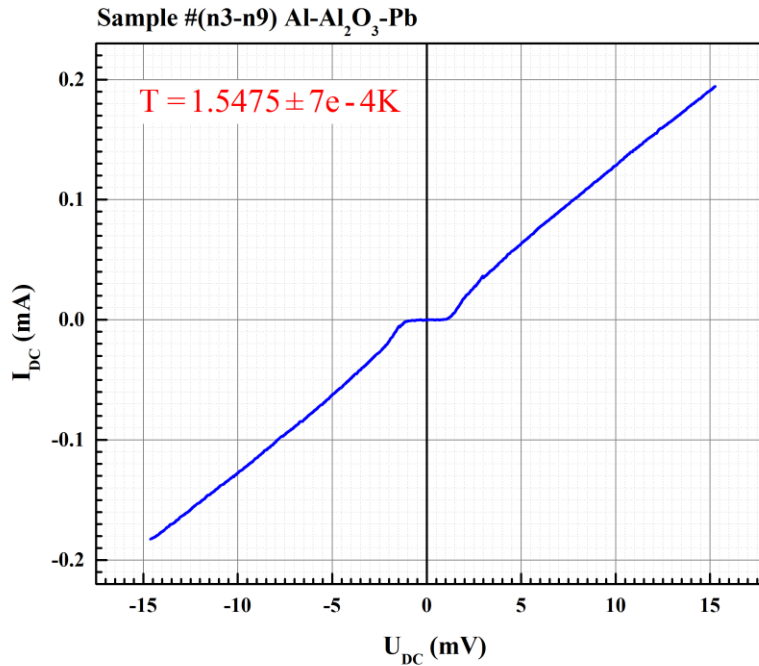

Courtesy of Anna Miller and Everett Vacek

Lock-in amplifier technique: demo

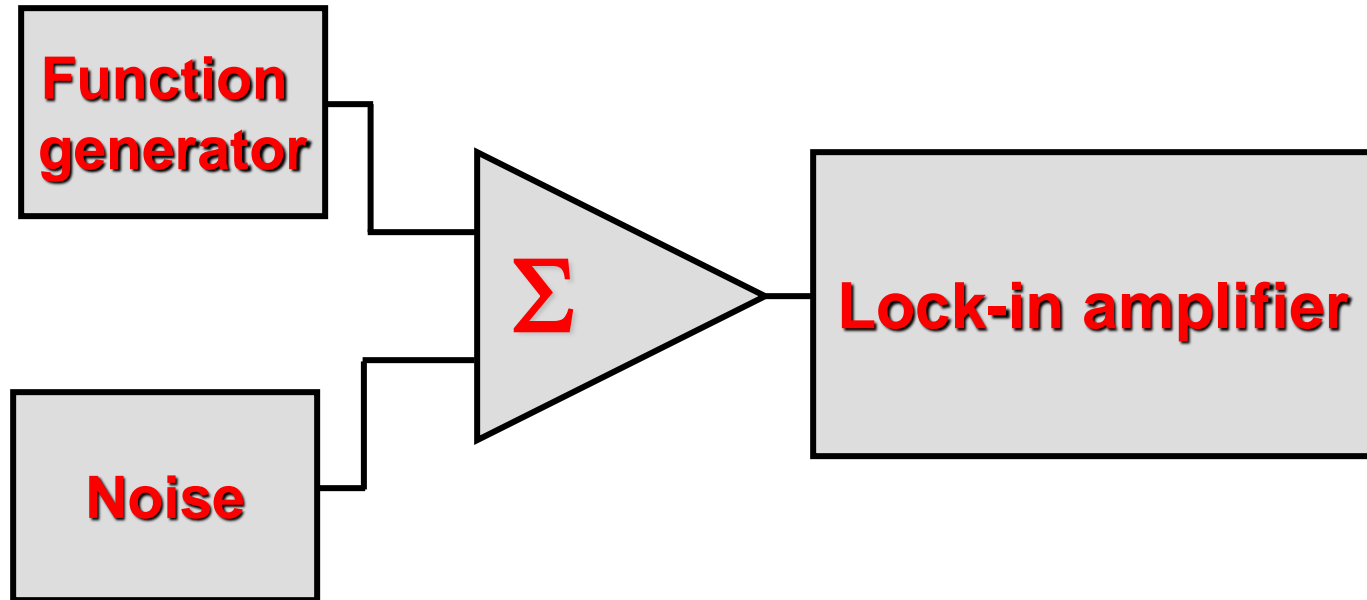

demo lock-in