

Shielding for Isotopic Beta Sources

Shielding for Beta Radiation

- ☞ Radiation associated with beta emitters
 - ☞ Electrons or positrons
 - ☞ Bremsstrahlung x-rays
 - ☞ In the case of a positron source, annihilation photons

- ☞ Beta shield consists of a low Z substance that is thick enough to stop the beta rays, followed by an outer layer of high Z material to attenuate the bremsstrahlung x-rays.

Beta Ray Shielding – An Example

Example 10.10

Fifty milliliters of aqueous solution containing 37×10^4 MBq (10 Ci) carrier free ^{90}Sr in equilibrium with ^{90}Y is to be stored in a laboratory. The health physicist requires the dose-equivalent rate at a distance of 50 cm from the center of the solution to be no greater than 0.1 mSv (10 mrem) per hour. Design the necessary shielding to meet this requirement.

The maximum and mean beta-ray energies of ^{90}Sr and ^{90}Y are as follows:

	$E_{\text{max}}, \text{MeV}$	$E_{\text{mean}}, \text{MeV}$
^{90}Sr	0.54	0.19
^{90}Y	2.27	0.93
Sum		1.12

Serial Transformation

In many situations, the parent nuclides produce one or more radioactive offsprings in a chain. In such cases, it is important to consider the radioactivity from both the parent and the daughter nuclides as a function of time.

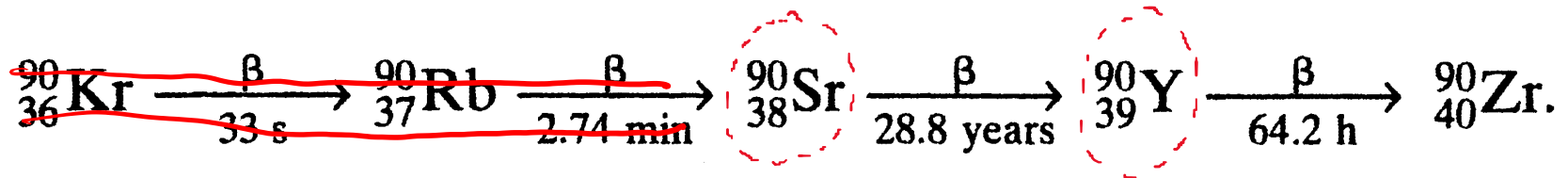

Due to their short half lives, ^{90}Kr and ^{90}Rb will be completely transformed, results in a rapid building up of ^{90}Sr .

^{90}Y has a much shorter half-life compared to ^{90}Sr . After a certain period of time, the instantaneous amount of ^{90}Sr transformed per unit time will be equal to that of ^{90}Y .

In this case, ^{90}Y is said to be in a secular equilibrium.

Secular Equilibrium: $T_A \gg T_B$ ($\lambda_A \ll \lambda_B$)

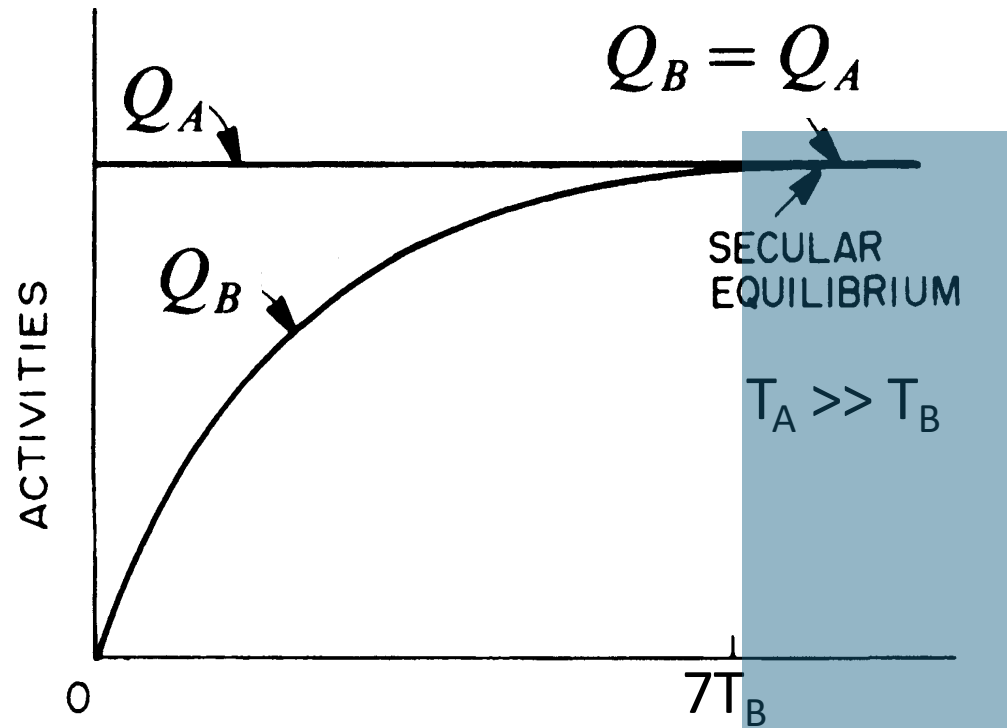

$$\lambda_A N_A = \lambda_B N_B$$

Part 1: Shielding for the Beta Particles

The range of the beta particles with the maximum energy of 2.27 MeV is 1.19g/cm² in polyethylene (density: 0.959 g/cm³). If polyethylene is used as the shielding material, the wall thickness of the shielding is chosen to be equal to the range,

$$t_{\text{wall}} = \frac{1.19 \text{ g/cm}^2}{0.959 \text{ g/cm}^3} = 1.26 \text{ cm}$$

Part 2: Extra Shielding for the Bremsstrahlung X-rays

The rate of beta energy emitted by the source of activity A is

$$\dot{E}_\beta = A \cdot \bar{E}_\beta = 3.7 \times 10^{11} \text{ Bq} \times 1.12 \text{ MeV/t}$$

The fraction of beta energy being converted to bremsstrahlung is

$$f = 3.5 \times 10^{-4} \cdot Z_{\text{eff}} \cdot E_{\text{max}}(\text{MeV})$$

where Z_{eff} is the effective Z of the absorbing material

$$Z_{\text{eff}} = \frac{\sum_i N_i Z_i^2}{\sum_i N_i Z_i} = 6.6 \text{ for polyethylene}$$

N_i : number fraction of the i 'th element

Z_i : atomic mass number of the i 'th element.

So

$$f = 3.5 \times 10^{-4} \cdot 6.6 \cdot 2.27 = 5.24 \times 10^{-3}$$

Maximum energy of the beta particles

Part 2: Extra Shielding for Bremsstrahlung X-rays

Assuming all X-rays are emitted from a point, the dose rate at a distance d is

Linear energy absorption coefficient for 2.27 MeV photons in air

$$\dot{D} = \frac{f \cdot \dot{E}_\beta \left(\frac{\text{MeV}}{\text{s}}\right) \cdot 1.6 \times 10^{-13} \left(\frac{\text{J}}{\text{MeV}}\right) \cdot \mu_{en} \left(\frac{1}{\text{m}}\right) \cdot 3.6 \times 10^3 \left(\frac{\text{s}}{\text{h}}\right)}{\rho_{air} (\text{kg}/\text{m}^3) \cdot 4\pi \cdot d^2 (\text{m}^2) \cdot 10^{-3} (\text{Gy}/\text{mSv})} = 1.14 \text{ mSv/h}$$

Suppose all bremsstrahlung photons have the maximum beta particle energy, 2.27 MeV.

The linear attenuation coefficient for 2.27 MeV photons in lead is 0.51 cm^{-1} . The thickness of lead needed to bring the dose at 0.5 m away to 0.1 mSv is given by

$$0.1 = 1.14 \cdot e^{-0.51(\text{cm}^{-1}) \cdot t(\text{cm})}$$

$$t = -\frac{1}{0.51} \ln \frac{0.1}{1.14} = 4.8 \text{ cm}$$

Scattered Gamma Rays and Characteristic X-rays

- ☞ The linear attenuation equation only accounts for how many photons passing through the shielding without interaction ...

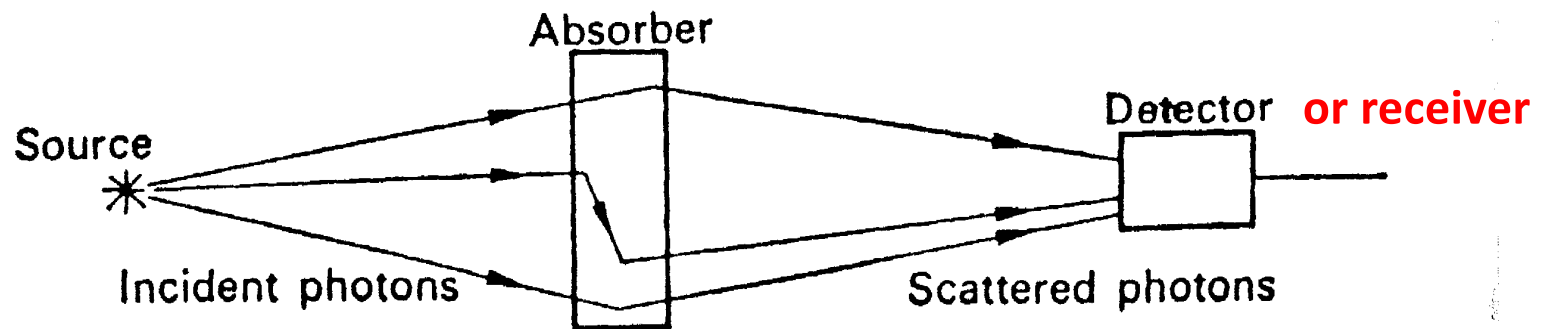

FIGURE 10.5. Gamma-ray absorption under conditions of *broad beam* geometry, showing the effect of photons scattered into the detector.

The Buildup Factor

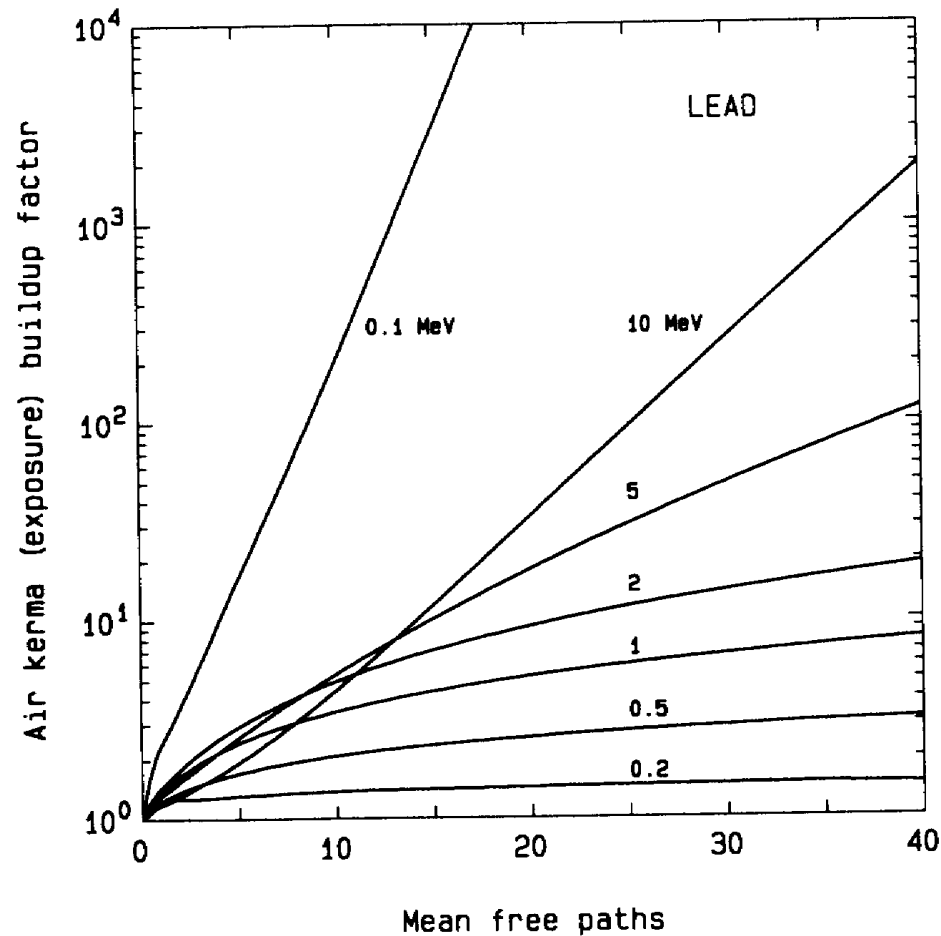

Figure 6.16 Air kerma (exposure) buildup factors for gamma-ray attenuation in lead. [Data are from Simmons and Eisenhauer, as reported in Chilton, Shultis, and Faw (1984).]

Part 2: Extra Shielding for Bremsstrahlung X-rays

Assuming all X-rays are emitted from a point, the dose rate at a distance d is

Linear energy absorption coefficient for 2.27 MeV photons in air

$$\dot{D} = \frac{f \cdot \dot{E}_\beta \left(\frac{\text{MeV}}{\text{s}} \right) \cdot 1.6 \times 10^{-13} \left(\frac{\text{J}}{\text{MeV}} \right) \cdot \mu_{en} \left(\frac{1}{\text{m}} \right) \cdot 3.6 \times 10^3 \left(\frac{\text{S}}{\text{h}} \right)}{\rho_{air} \cdot (k \text{ g/m}^3) \cdot 4\pi \cdot d^2 (\text{m}^2) \cdot 10^{-3} (\text{G}_y/\text{mS}_v)} = 1.14 \text{ mSv/h}$$

Suppose all bremsstrahlung photons having the maximum beta particle energy, 2.27 MeV. The linear attenuation coefficient for 2.27 MeV photons in lead is 0.51 cm^{-1} . The thickness of lead needed to bring the dose at 0.5 m away to 0.1 mSv is given by

$$0.1 = 1.14 \cdot e^{-0.51(\text{cm}^{-1}) \cdot t(\text{cm})} \cdot B(t)$$

Building-up Factor

$$t = ?$$