

Introduction to Monte Carlo methods and GEANT4

NPRES 441

04/20/2026

Yifei Jin, PhD, Research Scientist, NPRES

yifeij5@illinois.edu

Outline

- Lecture 1: Introduction to Monte Carlo and Geant4
 - What is Monte Carlo Technique?
 - Why Do We Learn Monte Carlo?
 - What is Geant4?
 - Project Assignment
- Lecture 2: Geant4 Basics
 - UI Commands
 - Run/Event/Step Actions
 - “Detector” Construction
- Lecture 3: Students Presentations

Example of an integral

How to calculate the integral of this function?

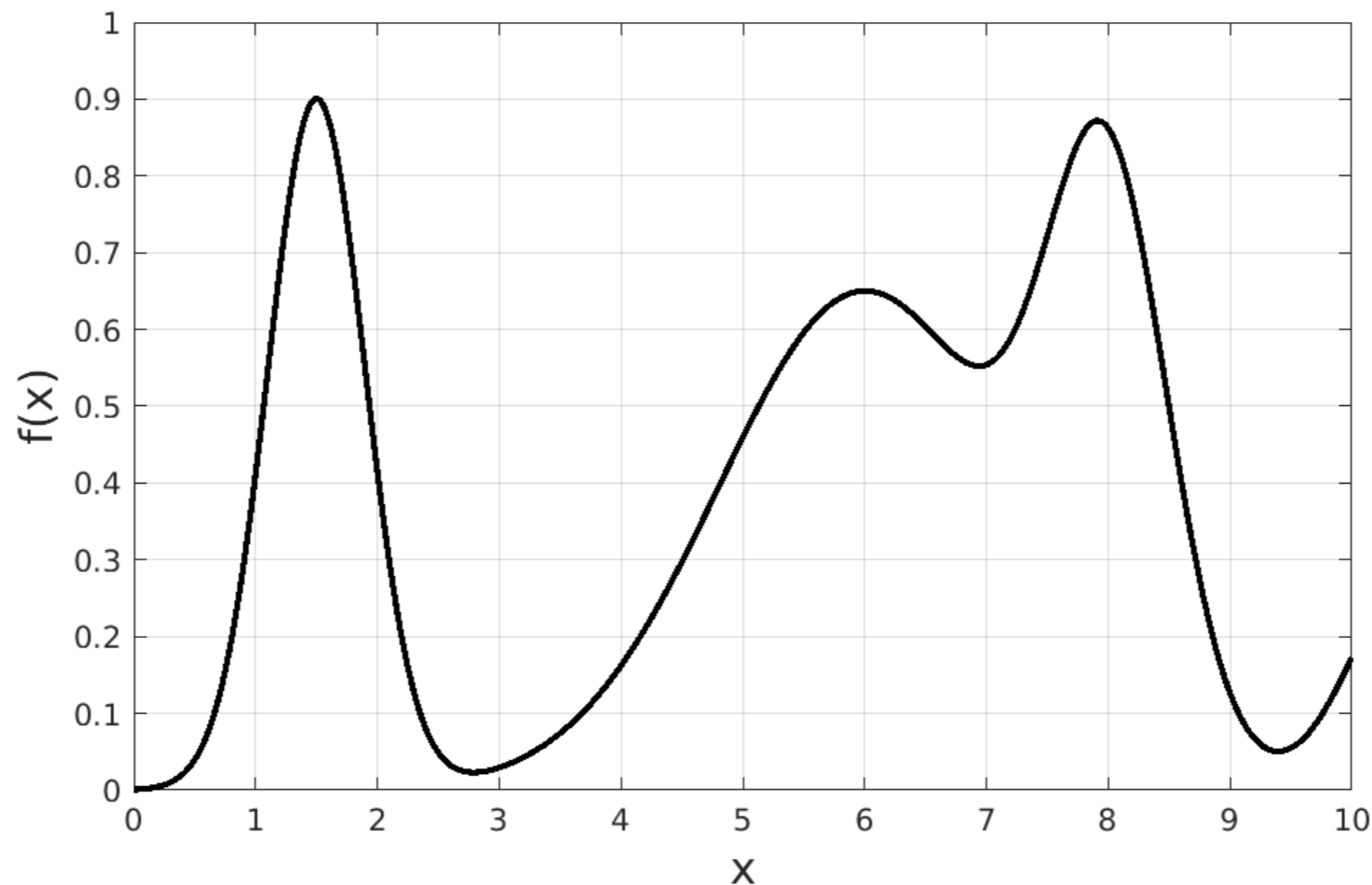

Analytical?

Numerical Integration?

Hey GPT! Calculate the integral for me?

Example of an integral

A fun method:

- The **orange points** are the accepted (n)
- The **blue** are the rejected ($N = \text{accepted} + \text{rejected}$)

$$p = \frac{I}{A} = \frac{n}{N}$$

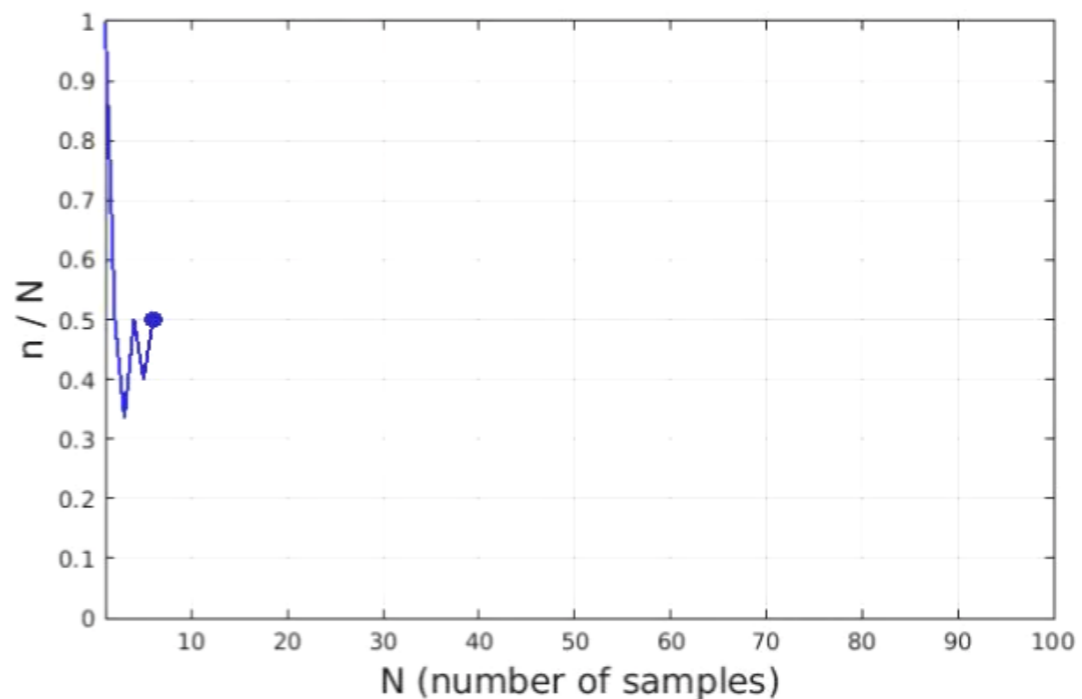
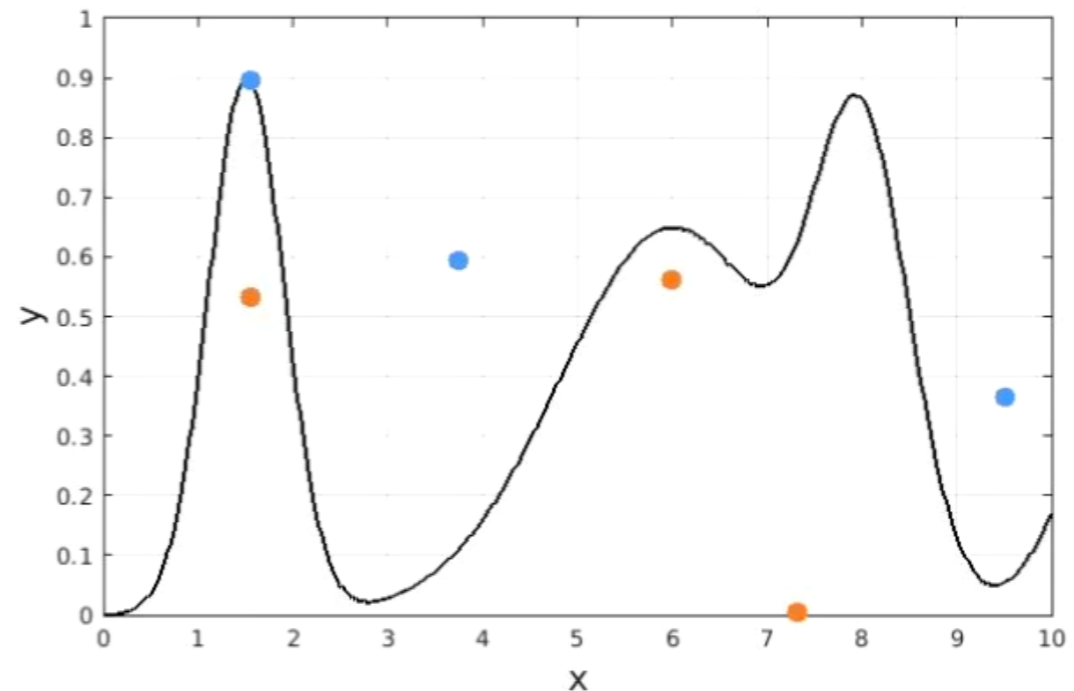

Example of an integral

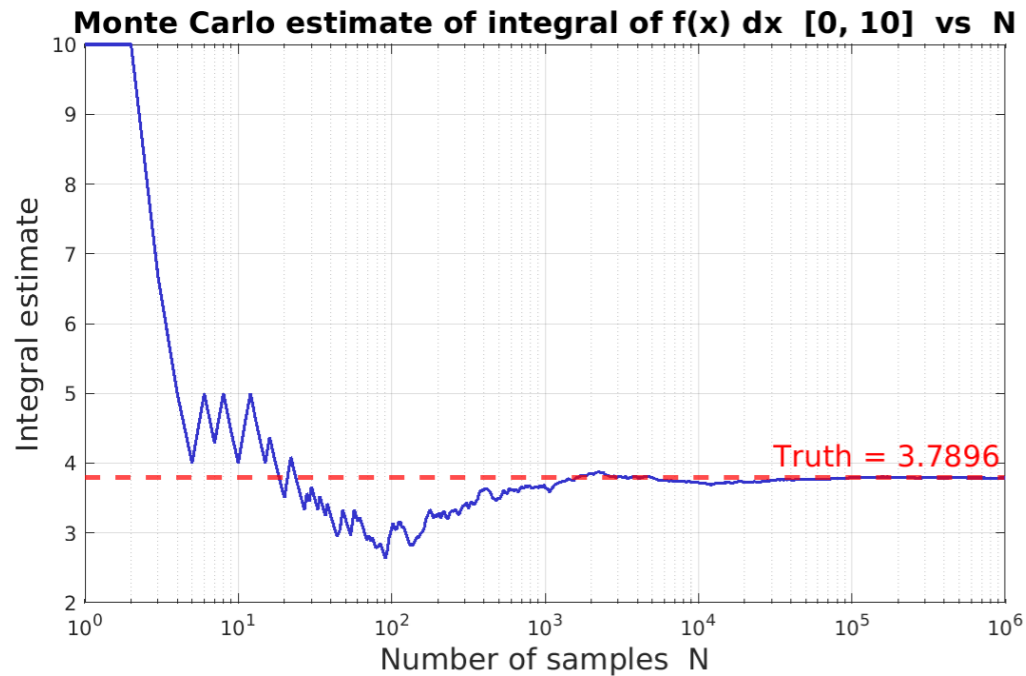

$$I = \frac{n}{N} A$$

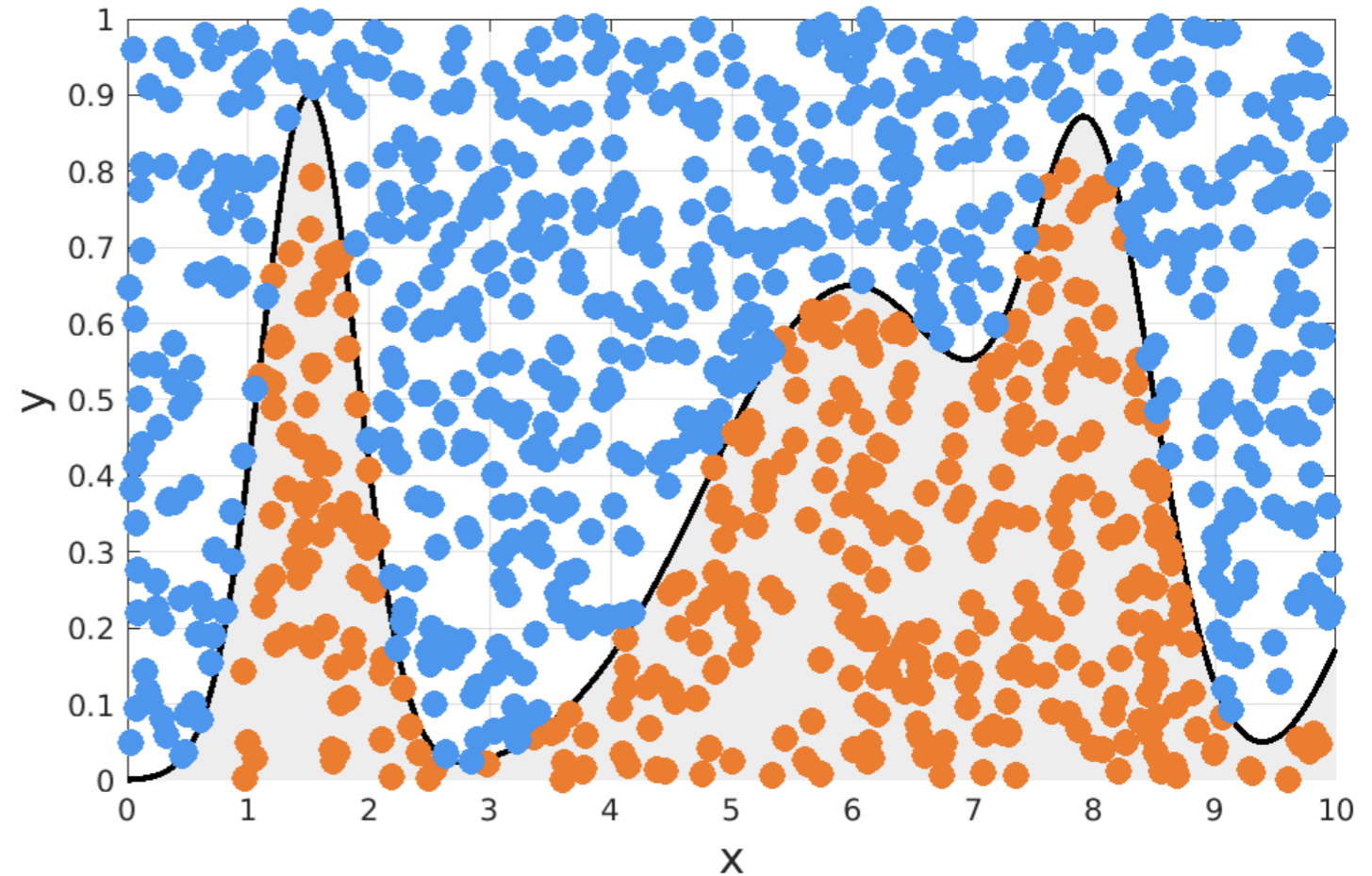

**Congratulations! You just invented
Monte Carlo method**

Monte Carlo Technique

- **Numerical solution** of a (complex) macroscopic problem, by simulating the **microscopic interactions** among the components
- Uses **random sampling**, until statistical **convergence** is achieved (name after **Monte Carlo's casino**)

**Key takeaway:
Use Random Number to
solve Deterministic problem**

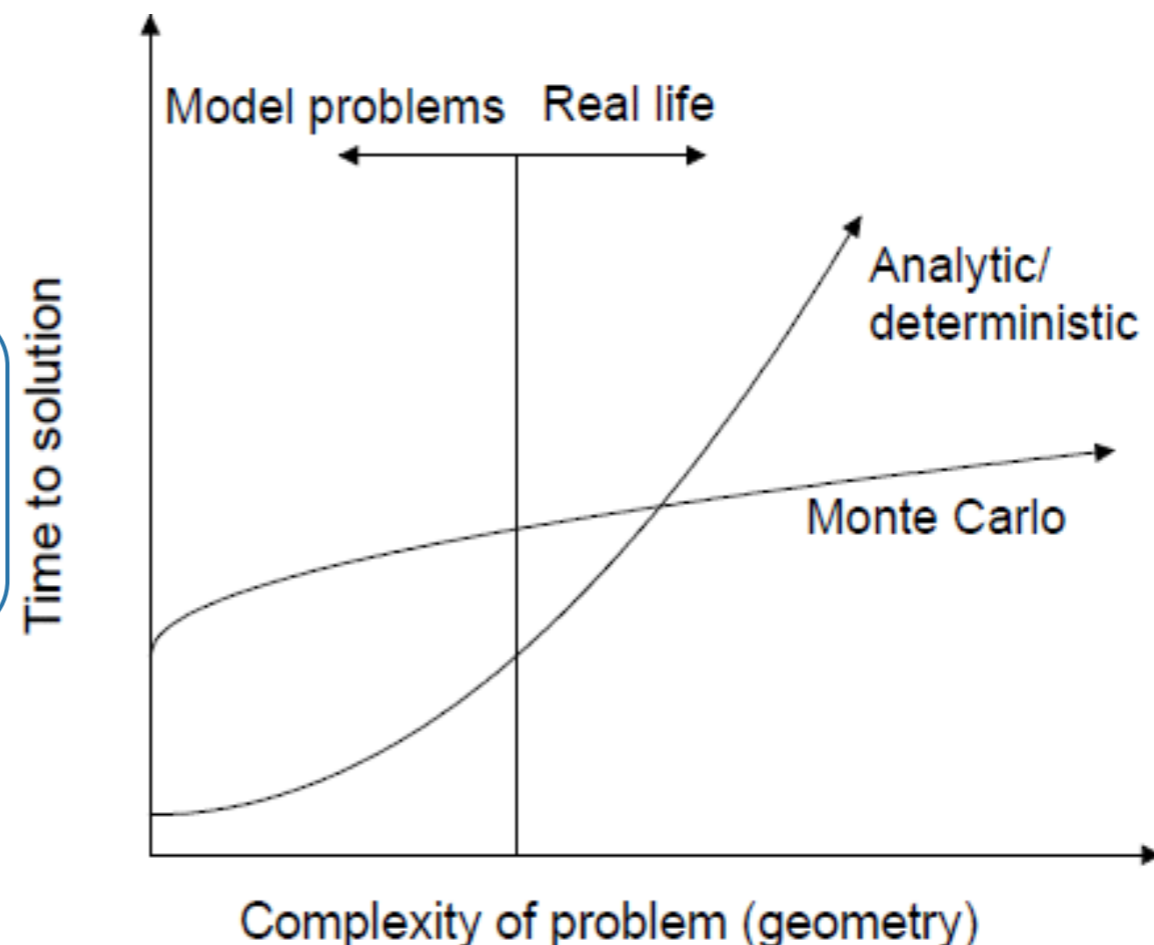

Why Do We Learn MC as a NPRE Student?

Nuclear Reactor

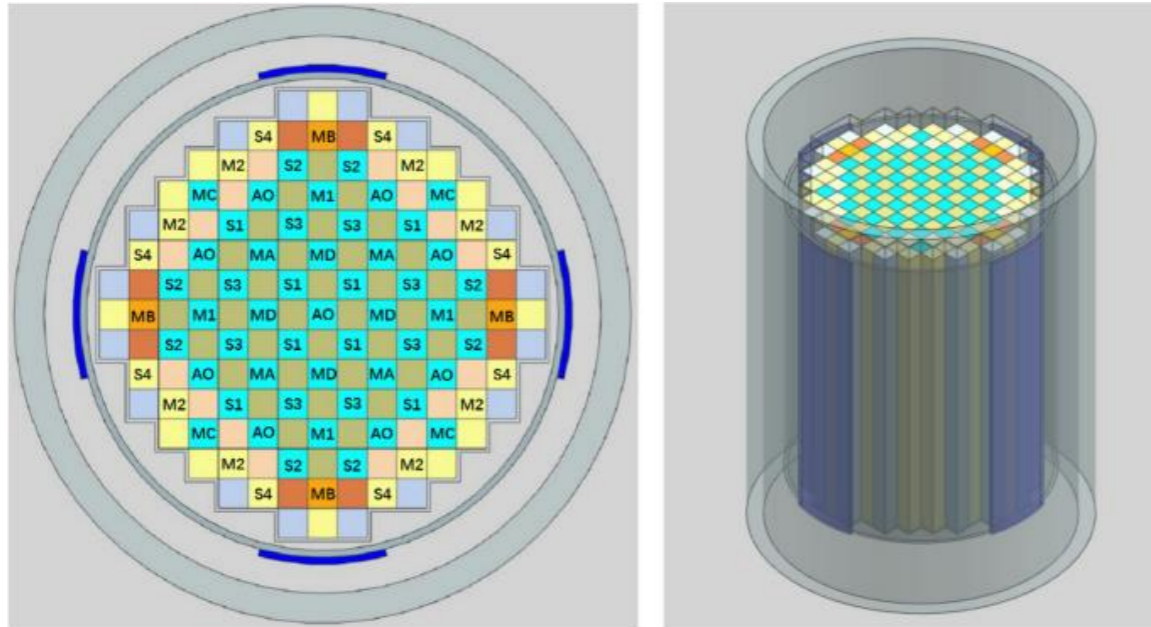

- Power distribution in the core
- Chain reaction (k -effective)
- Safety margins (avoid hot spots, meltdown)
- Fuel design and burnup

What particle transport determines the interaction characteristics?

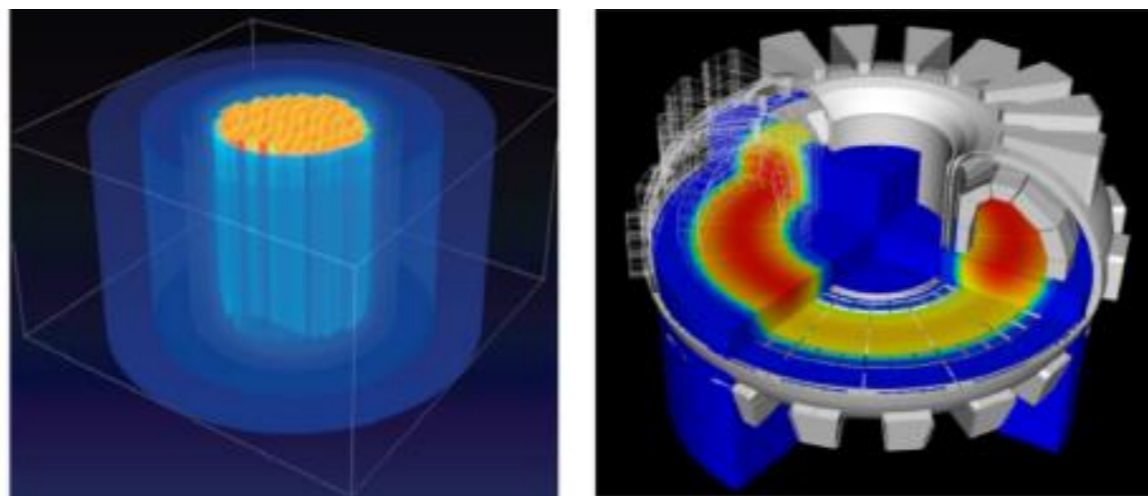

Neutron transport:

- Heterogeneous materials (fuel, moderator, control rods)
- Scattering, absorption, and fission
- Complex geometry
- Continuous neutron energy spectrum

Can deterministic methods solve neutron transport precisely when geometry, energy, and angle are all highly coupled?

Why Do We Learn MC in this class?

Dosimetry planning



radiotherapy

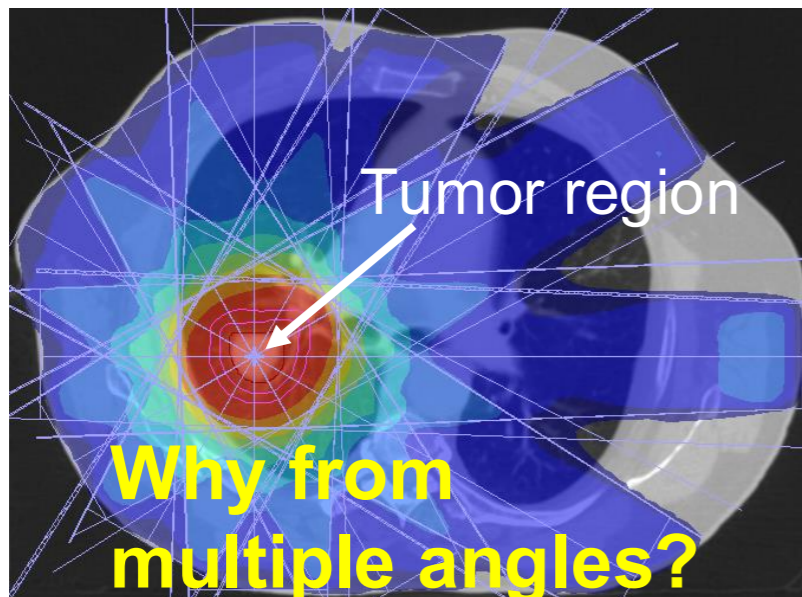

Radiotherapy (radiation therapy) is a **precise cancer treatment** that uses **high-energy radiation**—such as **X-rays**, **gamma rays**, or **protons**—to damage the **DNA** within **cancer cells**, **killing them** or preventing them from dividing.

How to model radiation transport and interaction with complex human tissue precisely?

Objectives:

1. maximize the radiation dose to a target tumor
2. minimizing exposure to surrounding healthy tissues

Why Do We Learn MC in this class?

Nuclear Reactor

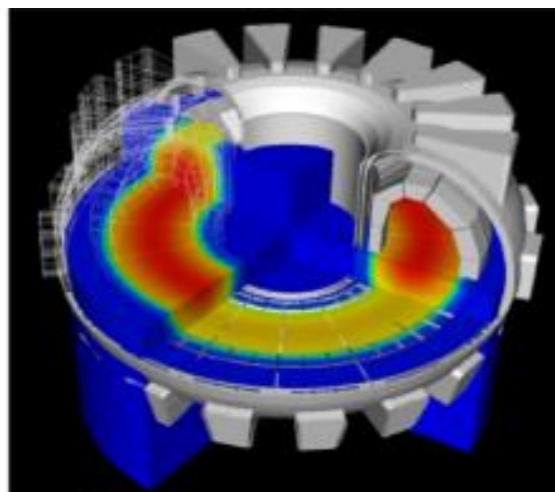
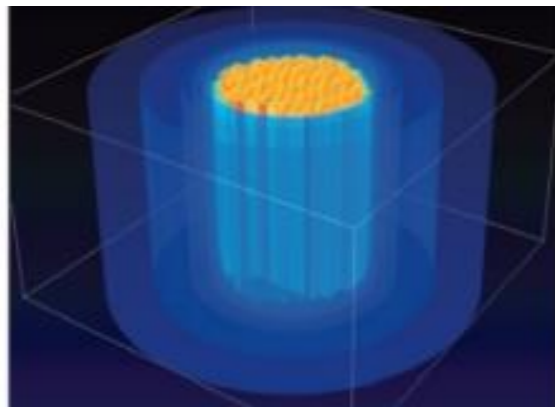

How do neutrons move and interact in a reactor?

Dosimetry planning

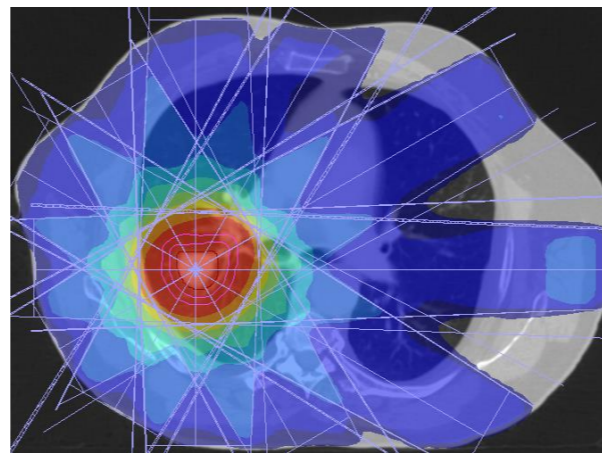

How to model radiation transport and interaction in human?

Radiation Protection

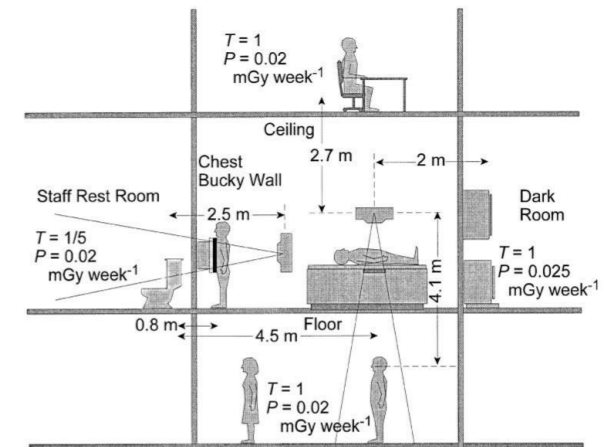

How to design the protection with so many elements?

Monte Carlo method

A bit of history

Concept of MC is much older than real computers
one can implement the algorithms manually, i.e., dice



Needle Problem Monte Carlo estimate of π
Buffon-Laplace proposed this in the 18th century

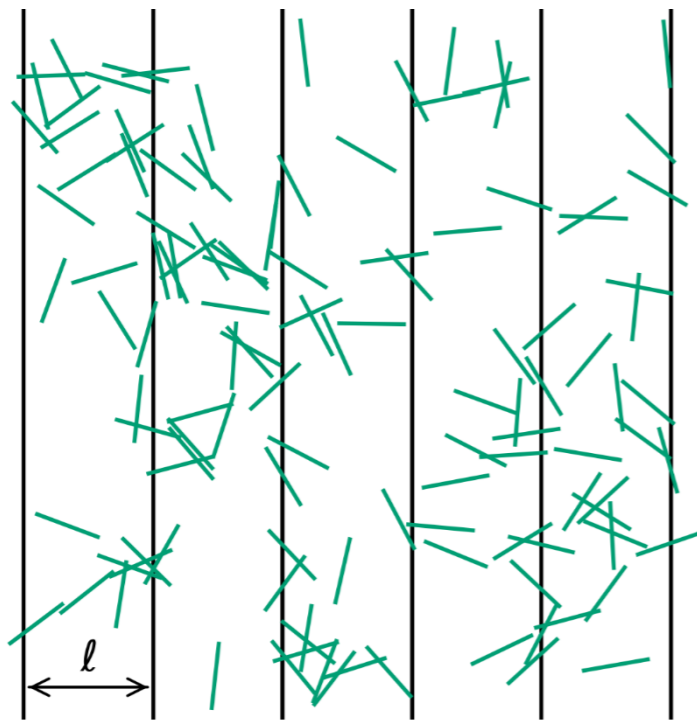

- l : distance between lines
- d : length of needles
- n : # of needles intersecting with lines
- N : Total # of needles

If $d \leq l$:

$$\pi = \frac{2l}{Pd} = \frac{2lN}{nd}$$

Monte Carlo is not just a numerical trick.
“It’s a way of solving problems by turning them
into **random experiments**”

A bit of history

- Boost in the **1940s** (Ulam and Von Neumann) for the development of **thermonuclear weapons**
- **Von Neumann** invented the name "**Monte Carlo**" and settled a number of **basic theorems**
- **First (proto)computers** available at that time
- MC mainly **CPU load**, minimal I/O

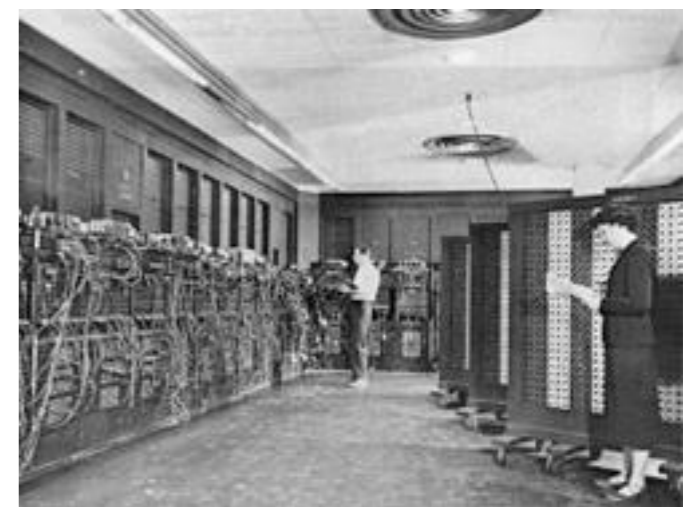

Monte Carlo Technique

Necessary Conditions (Mathematical Validity)

- **Expectation Mapping**: The **target value** must be **expressible** as an **expected value**.
- **Finite Mean**: Required by the **LLN (Law of Large Numbers)** to ensure the **sample average converges** to a single value.
- **Finite Variance**: Required by the **CLT (Central Limit Theorem)** to ensure a stable **convergence** rate and a **valid** error bound.
- **Measurability**: The problem must be defined in a **measurable** space

**Monte Carlo is not heuristic—
it's mathematically rigorous.**

Counter-example: Cauchy Distribution

The Cauchy distribution has **heavy tails**. These tails generate extreme outliers

Since it lacks a **finite mean and variance**, the MC average will randomly **"jump"** forever, **failing to converge** to any value.

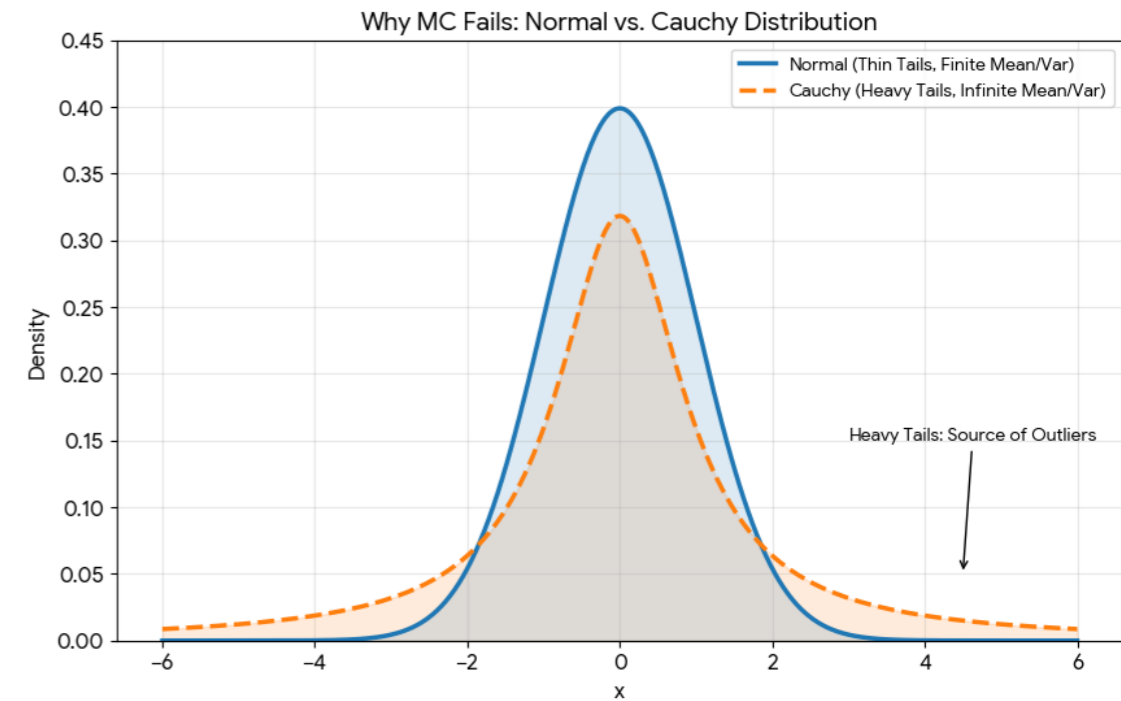

Run a MC simulation to estimate mean: Normal vs Cauchy

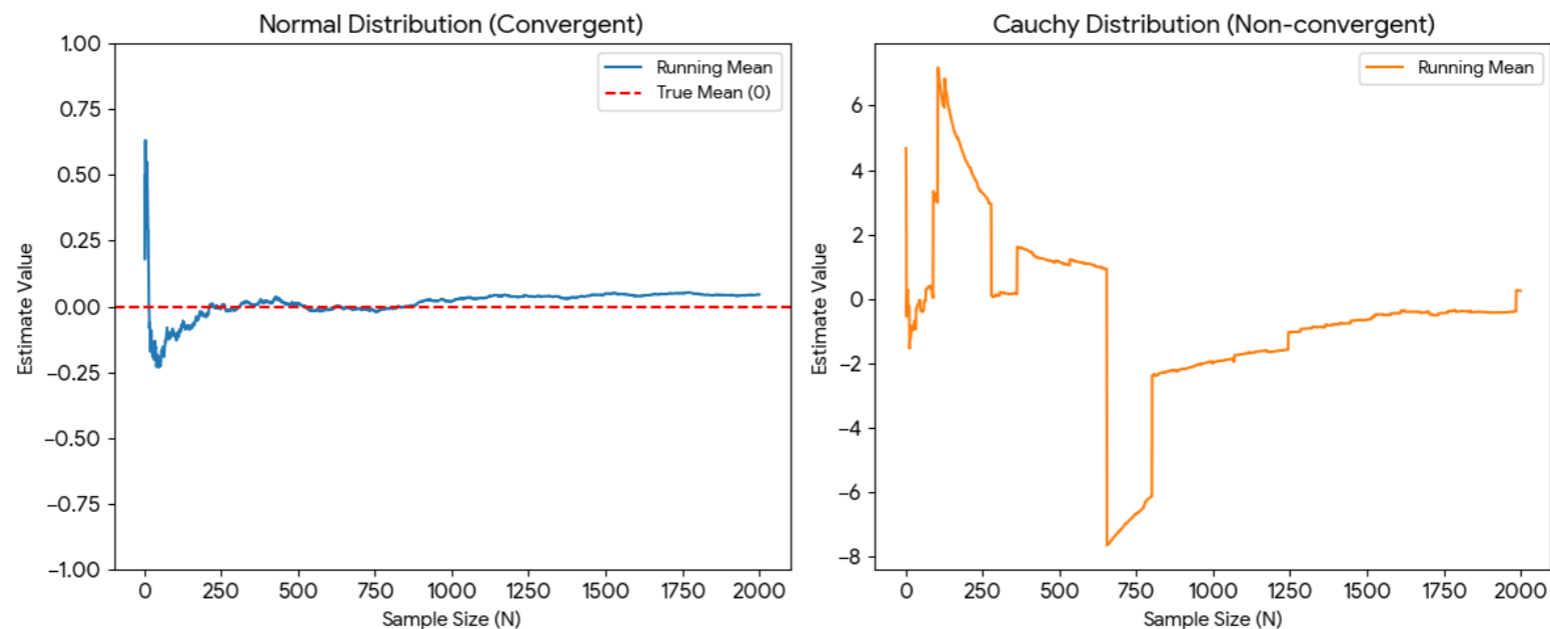

MC in Science

- **Elementary laws** are (typically) **known** => MC is used to **predict** the outcome of a (complex) experiment
 - **Optimize** an experimental **setup**, support **data analysis**
 - Can be used to **validate/disprove** a theory, and/or to provide small **corrections** to the **theory**

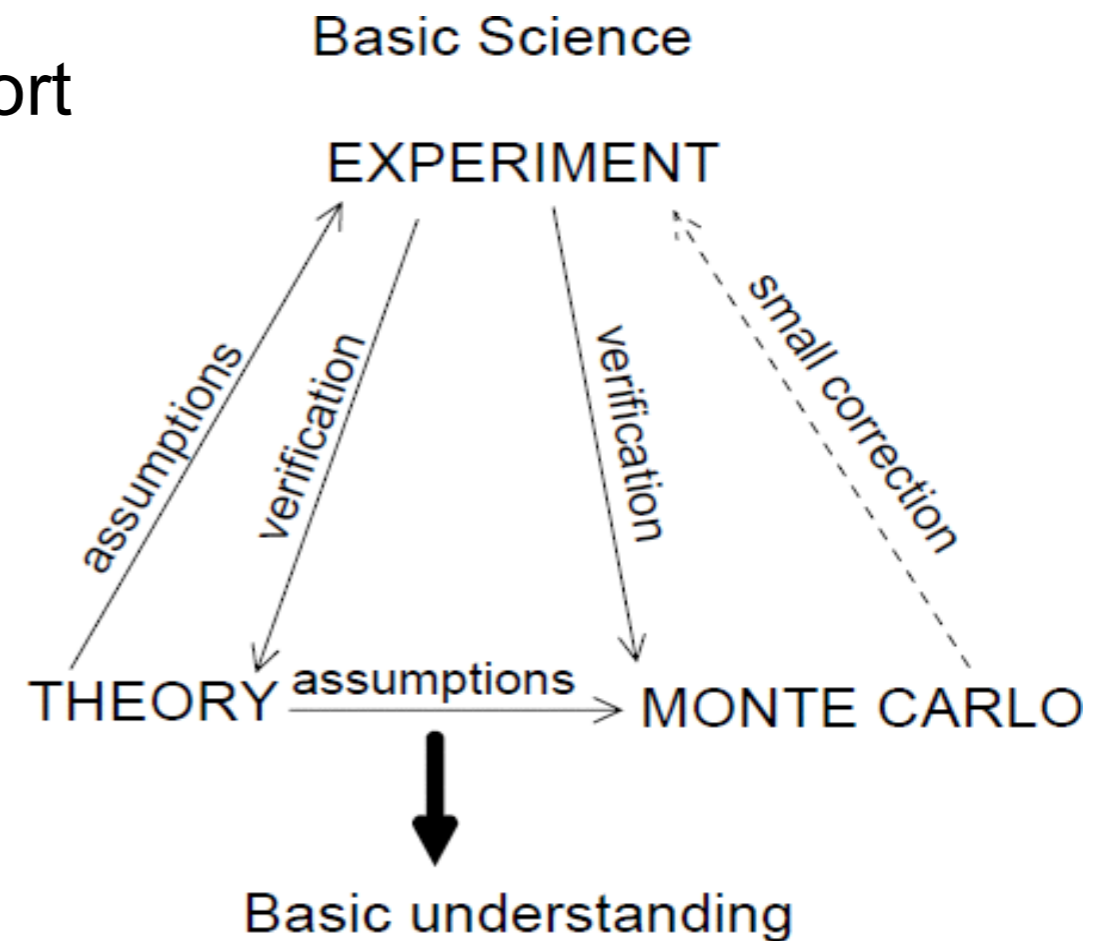

In this course: Monte Carlo for particle transport

Particle Transport with MC for

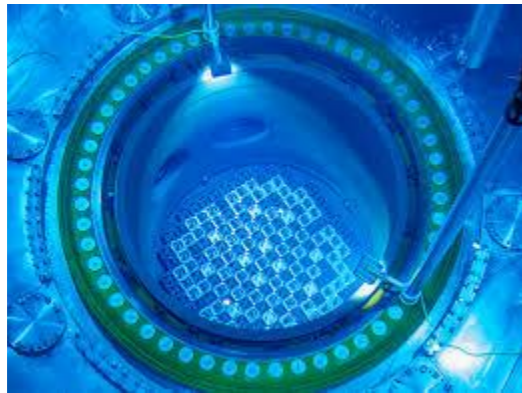

Nuclear Reactor Physics

Simulating **neutron transport** to calculate **criticality**, **flux distribution**, and **fuel burnup**.



Medical Physics & Radiotherapy

Dosimetry planning: Predicting exactly how **radiation** deposits **energy** in **human tissue** to destroy **tumors** while sparing **healthy organs**



Radiation Shielding & Protection

Designing **shielding** for **nuclear facilities** or **spacecraft** by calculating the **leakage** and **attenuation** of high-energy **particles** through **complex geometries**.

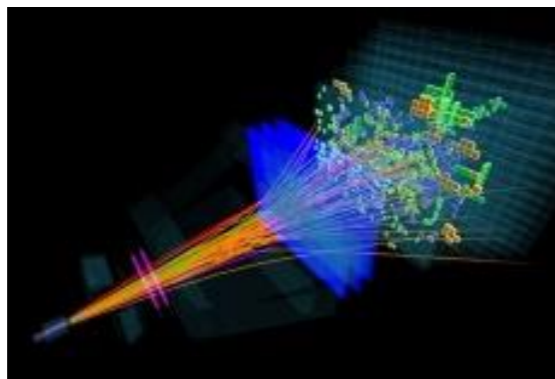

High Energy Physics (HEP)

Simulating **detector** responses in particle **accelerators** (like the **LHC**).

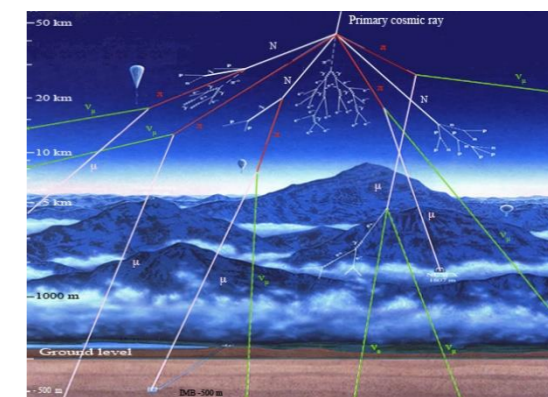

Atmospheric & Astrophysics

Modeling the **path** of **cosmic rays** through the **atmosphere** or the **diffusion** of light (photons) through **interstellar clouds** and stellar **atmospheres**.

Particle Transport with MC

- **Macroscopic problem** \Rightarrow **Microscopic interactions**
- **Random sampling**

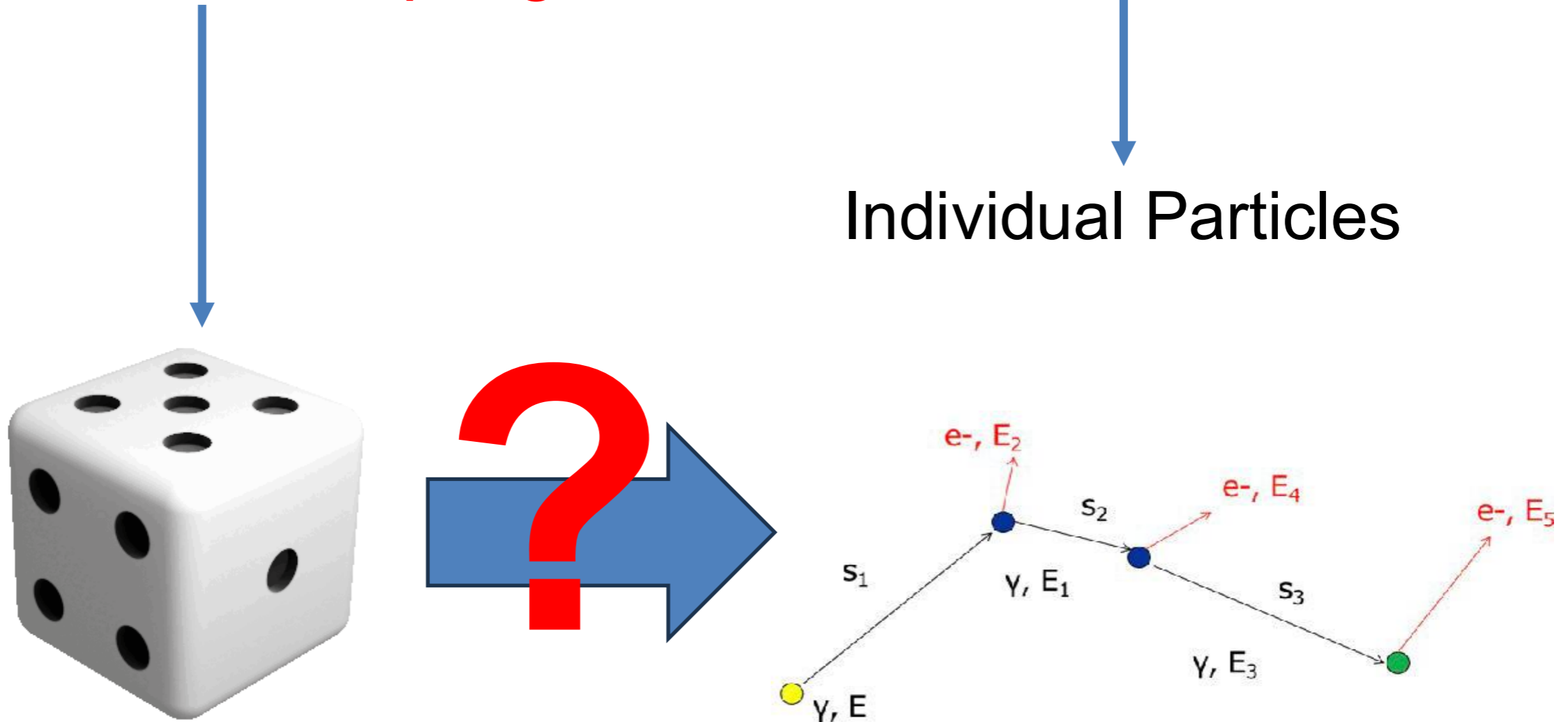

How do we simulate individual particle transport with random numbers?

Particle Transport

- **Physics-Driven Logic**: Utilizes geometry and material cross-sections to model discrete microscopic interactions
- The "Random Walk": Each particle's path is determined by probabilistic sampling of interaction types, scattering angles, and energy losses.

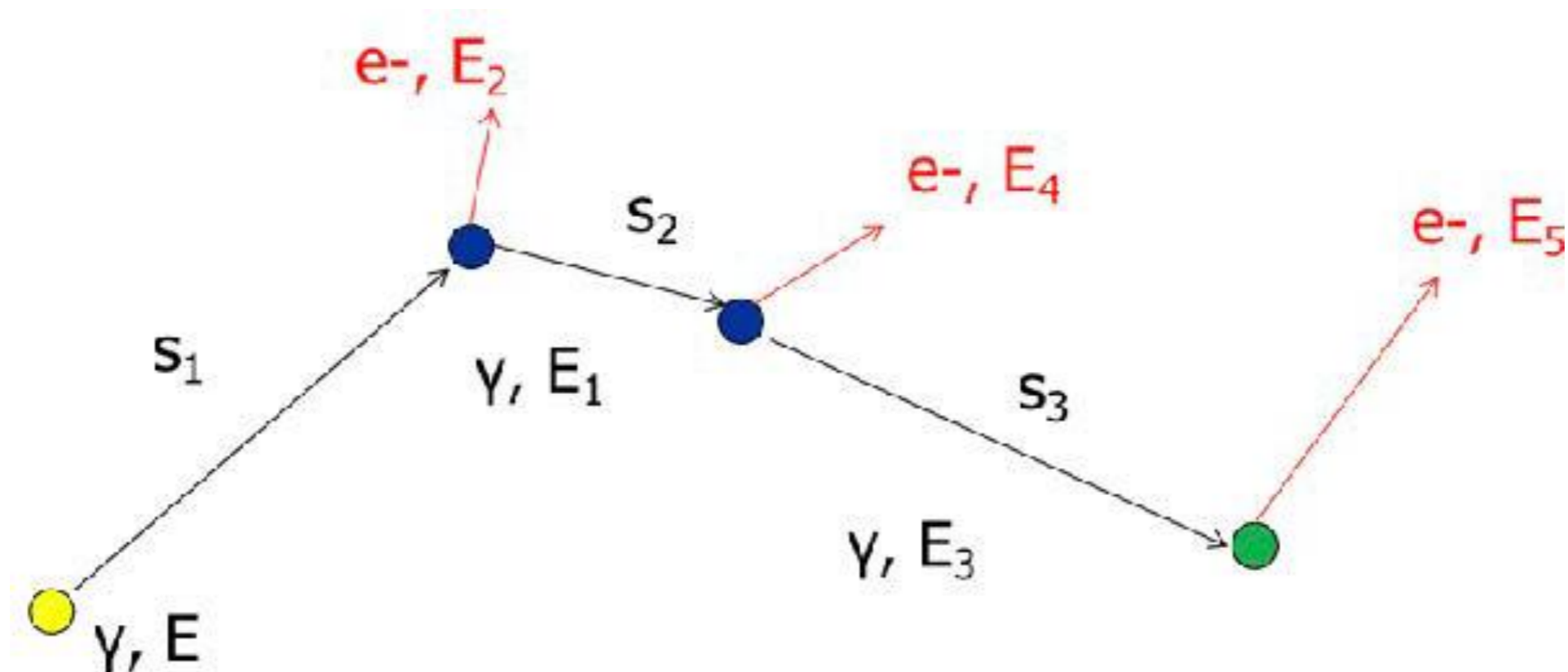

Particle Transport

•The "Random Walk":

- A particle's **trajectory** is treated as a sequence of **independent "steps"** and **probabilistic** events.
- **Distance to Next Collision:** The step length (s) is sampled from an exponential distribution $p(s) = \mu e^{-\mu s}$, where μ is the interaction probability per unit length.
- **Energy and Angle:** Physics models are used to sample the final state (kinematics)
- **Type of Interaction:** Competing processes (such as Scattering, Absorption, or Fission) are sampled according to their **differential cross-sections** (μ_i/μ).
- **Secondary Production:** The primary particle's properties are updated, and any produced **secondaries** are added to a stack to be tracked individually until they are absorbed or leave the geometry

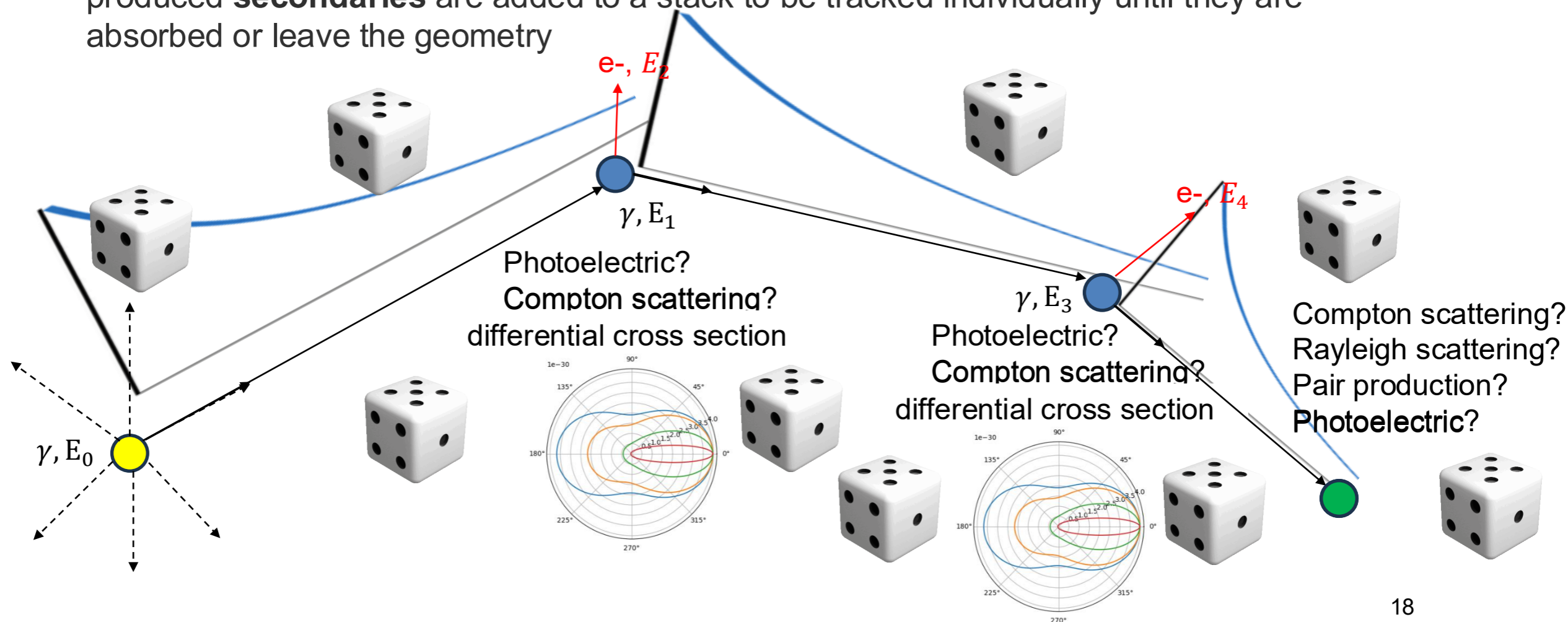

Example: 100-MeV proton beam in water

10 simulated proton trajectories in water ($E_p=100$ MeV):

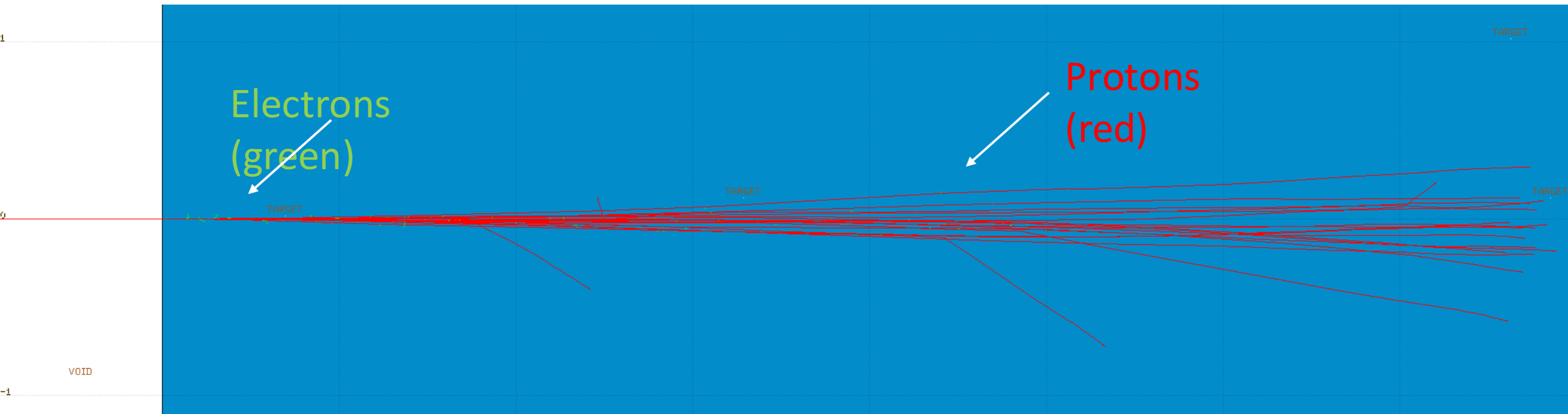

Statistical uncertainties

- Example: 100-MeV proton beam on water

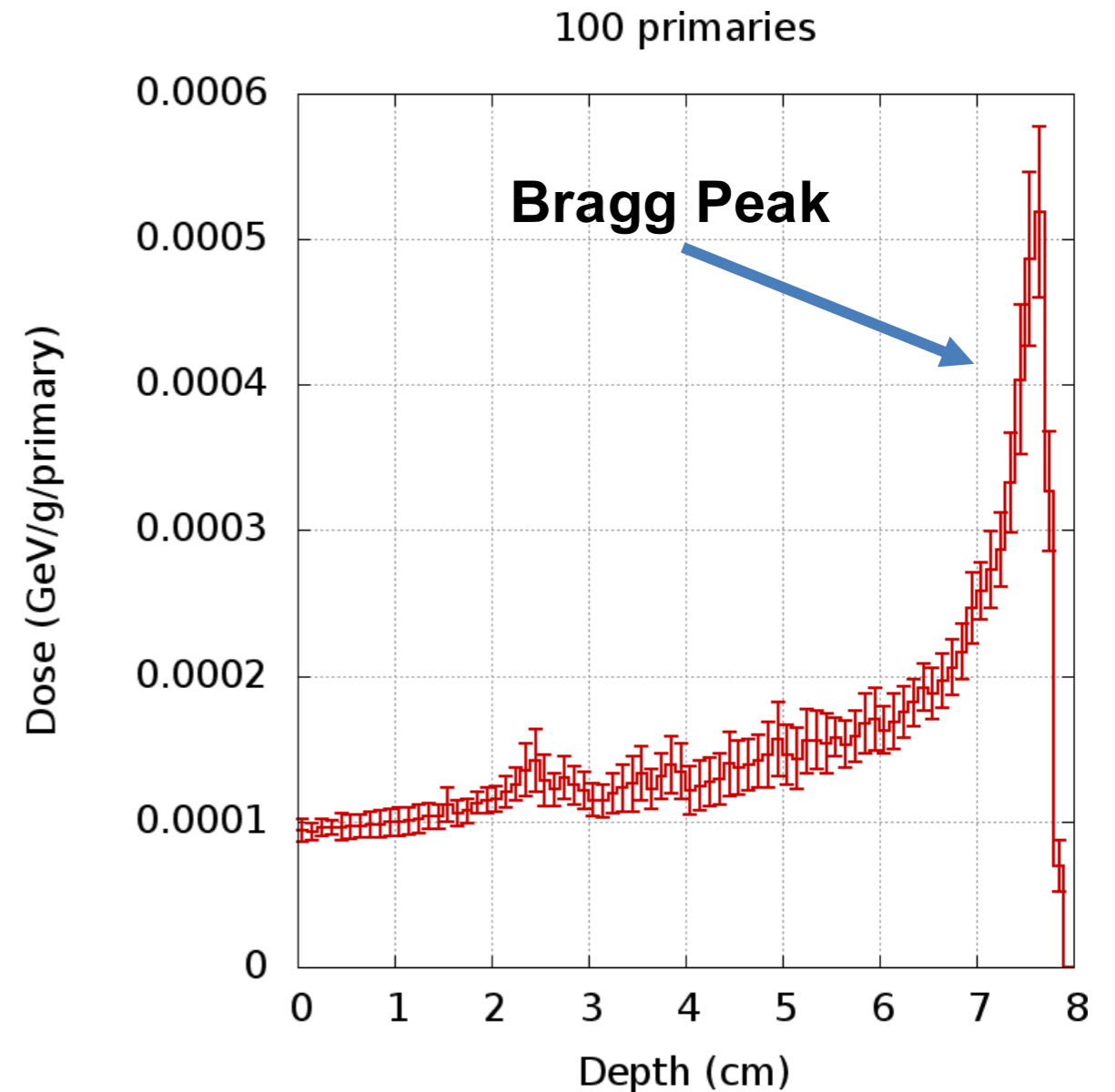
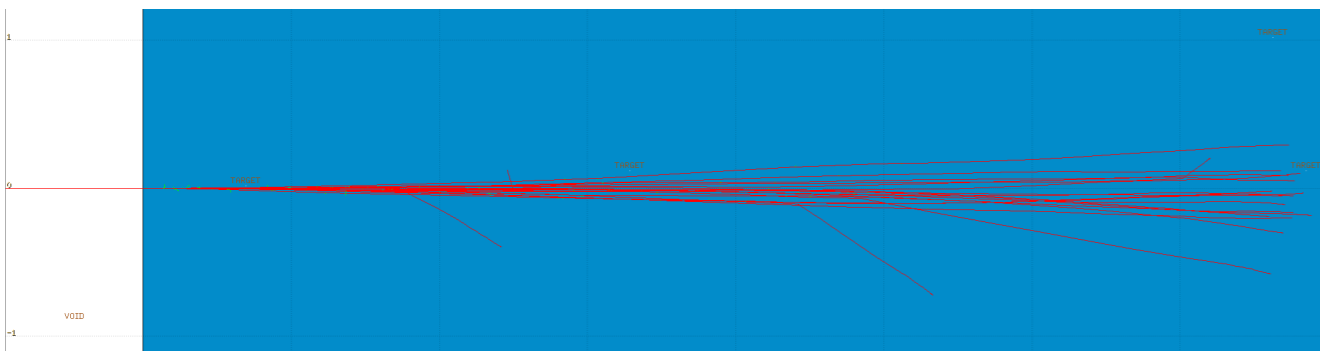

What if we increase the number of primaries?
Will x and y change? What else will change?

Statistical uncertainties

Example: 100-MeV proton beam on water

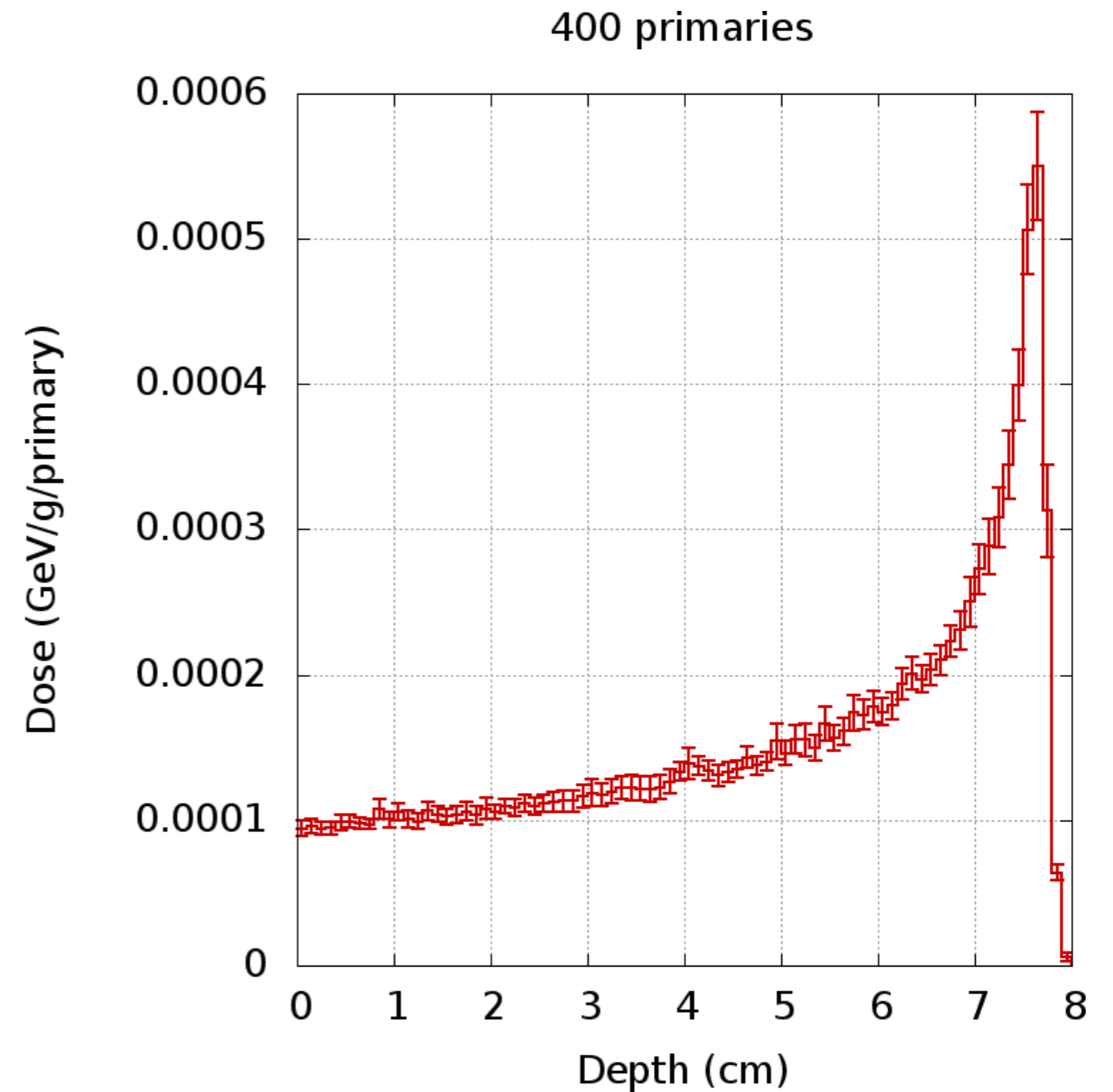

Statistical uncertainties

Example: 100-MeV proton beam on water

- Results from MC simulations are affected by statistical uncertainty
- The larger the number of primaries, the smaller the error bars.

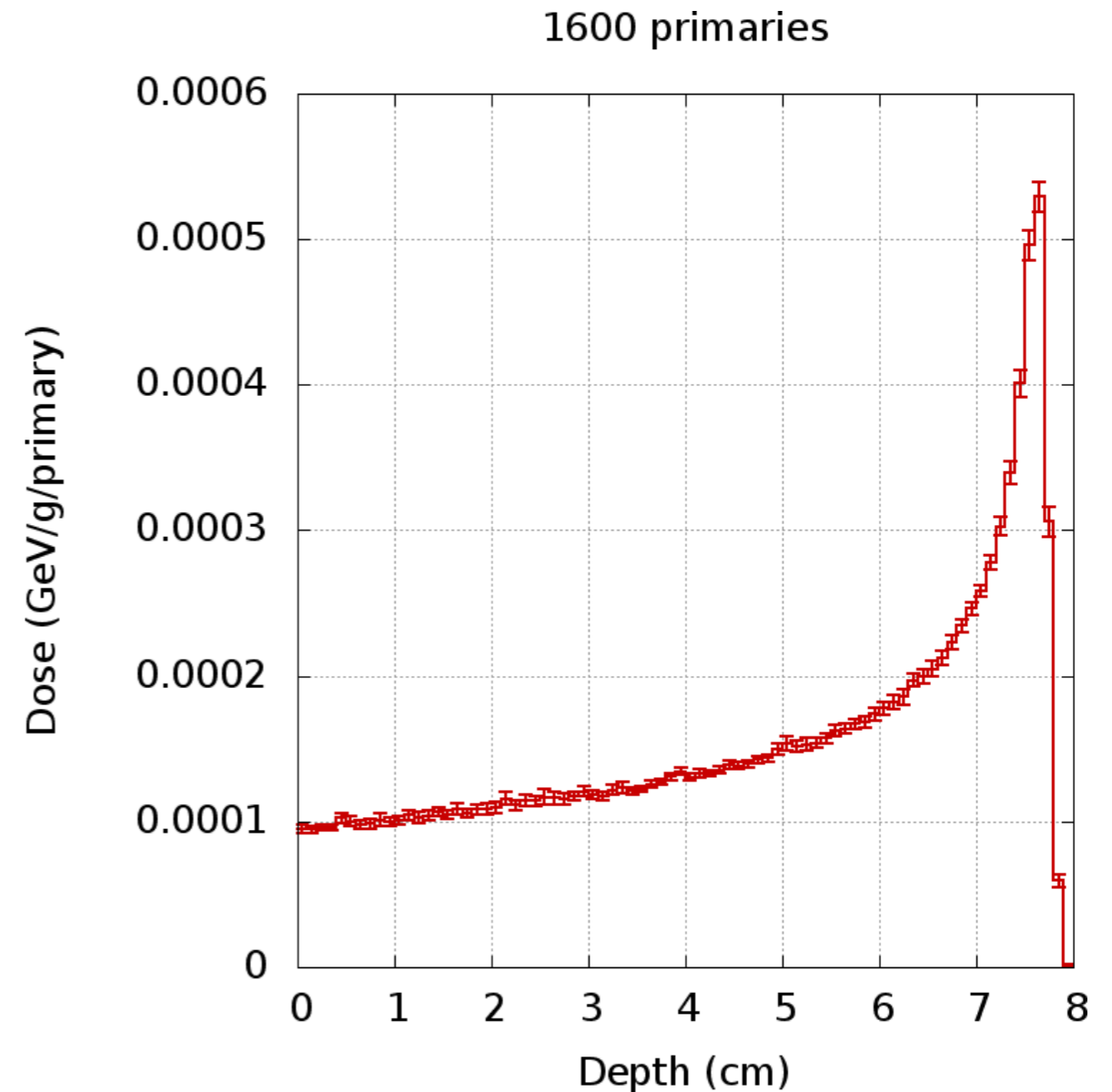

Tracking, not so easy...

- **Complex 3D geometry (millions of volumes)**
- **Massive cross-section databases**
- **Full physics:** EM + hadronic + charged particles
- **Extreme compute:** billions of particle tracks
 - Primary + Secondaries + Secondaries of Secondaries....

Luckily, We stand on decades of collective work

Toolkit	Primary Application
MCNP	Nuclear reactor design and criticality.
FLUKA	Particle physics and radiobiology.
Geant4	The "gold standard" for high-energy physics and complex medical imaging.



Geant4 (GEometry ANd Traking)

- Developed by an International Collaboration at CERN
 - Established in 1998
 - Approximately 100 members, from Europe, US and Japan
 - <http://geant4.org>
- Open source
- Written in C++ language
- A lot of examples from basic to advance. (Don't have to create a Geant4 project from nothing.)

[Geant4, a simulation toolkit Nucl. Inst. and Methods Phys. Res. A, 506 250-303

Geant4 developments and applications Transaction on Nuclear Science 53, 270-278]



CERN

Conseil Européen pour la Recherche Nucléaire (European Organization for Nuclear Research)

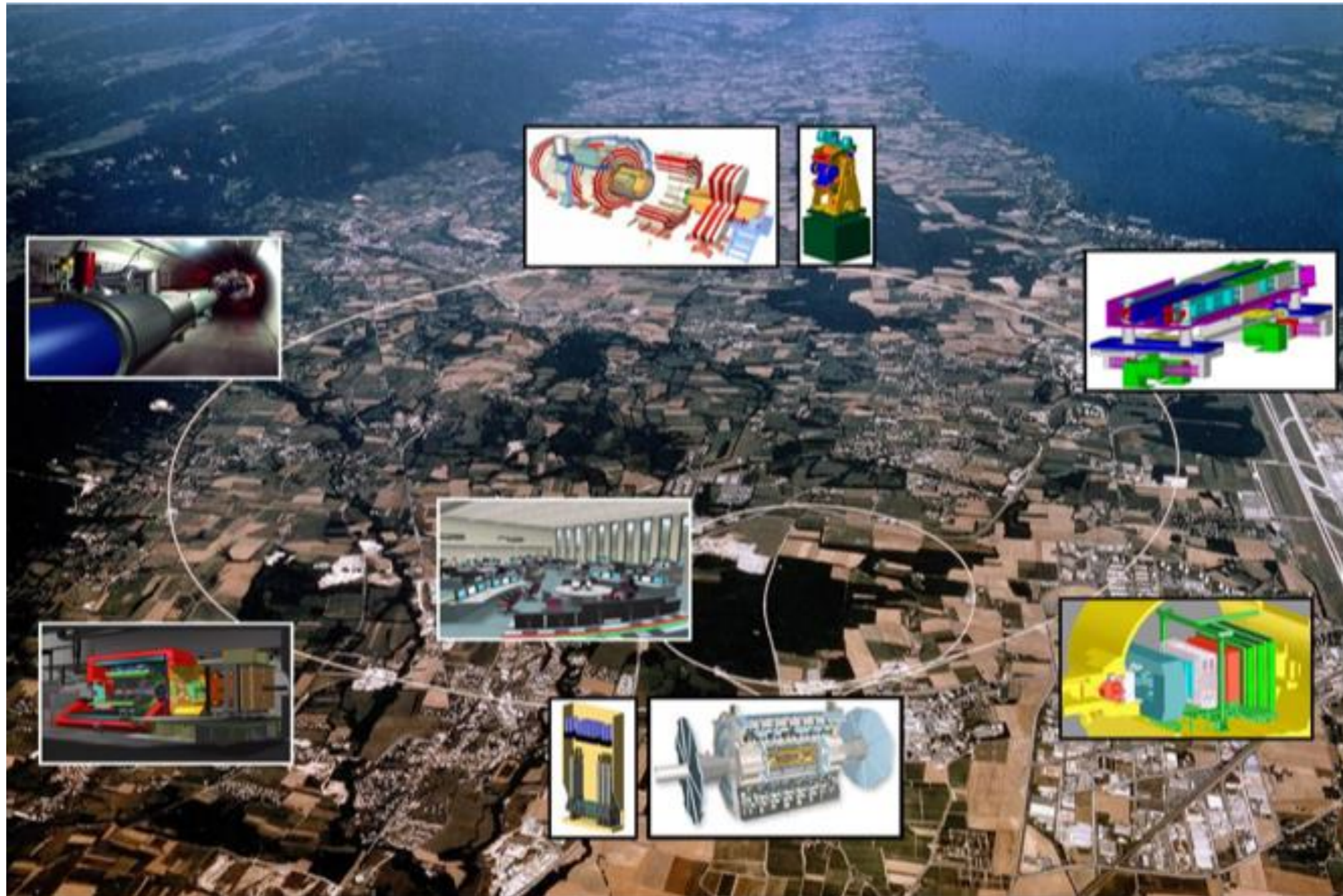

LHC @CERN

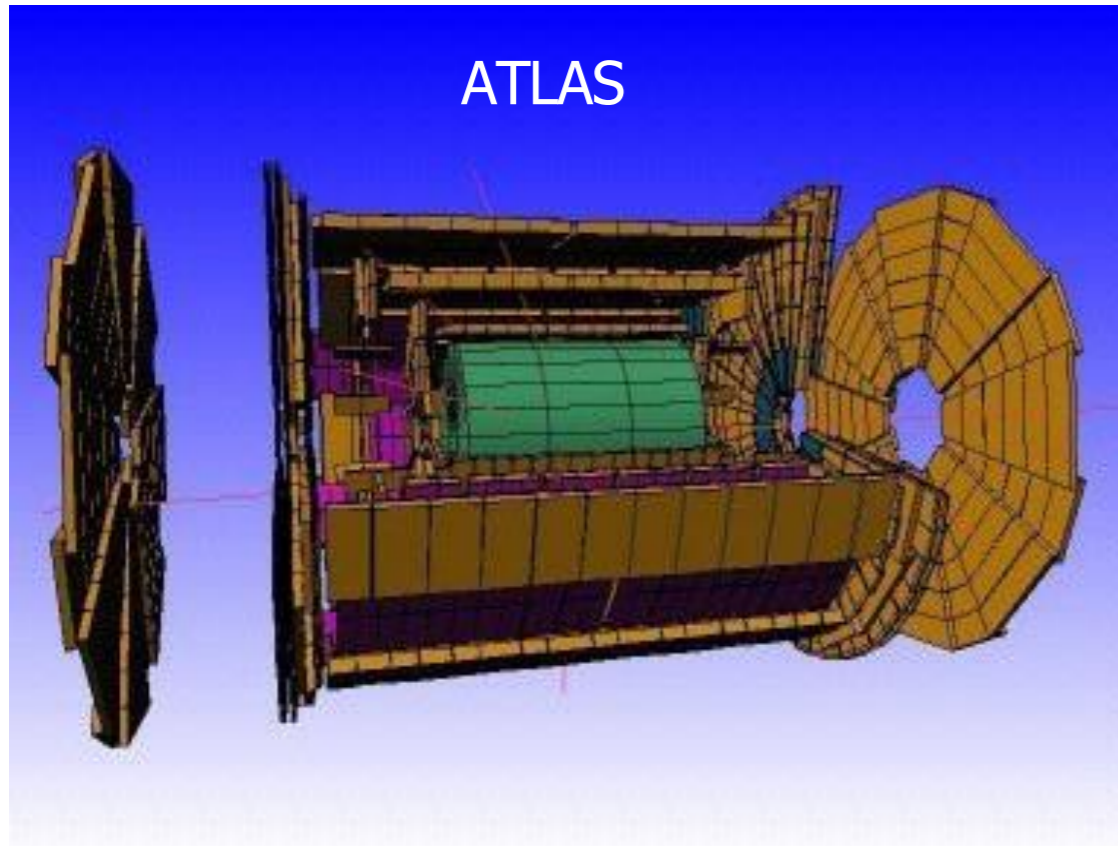

- All big **LHC experiments** have a **Geant4 simulation**
 - Millions of volumes
 - Physics at the TeV scale

- Benchmark with test-beam data
- Key role for the Higgs searches

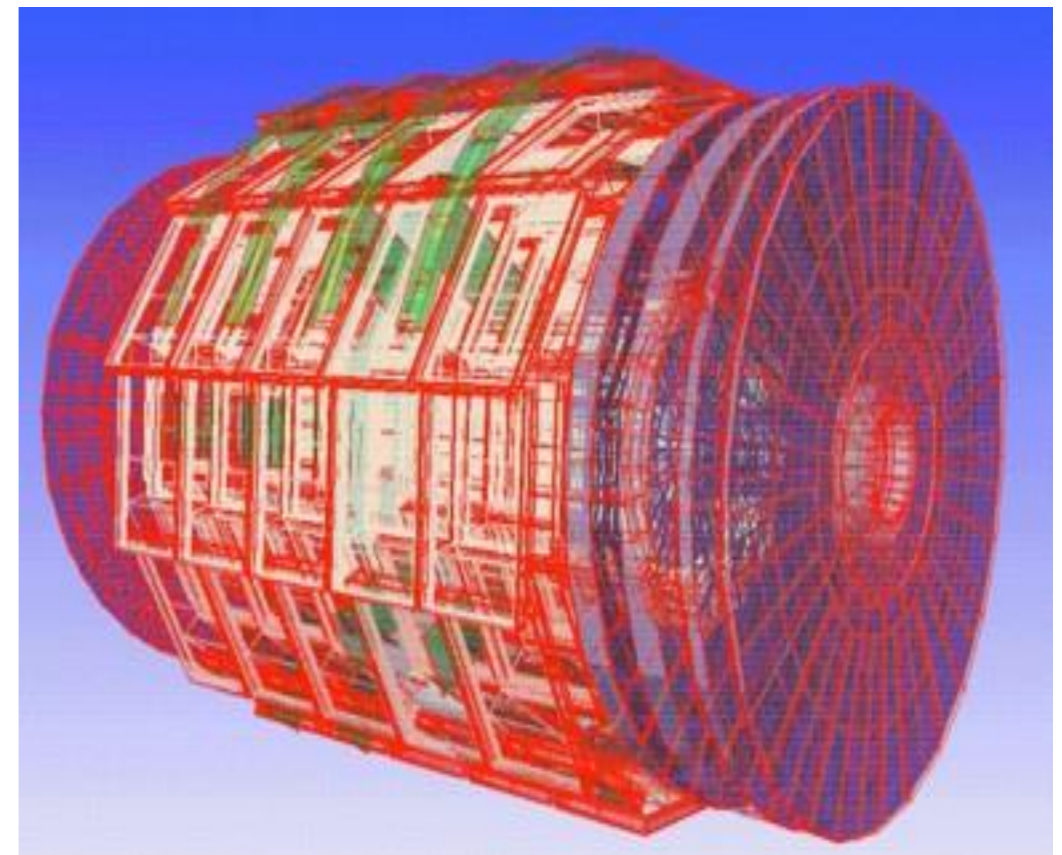
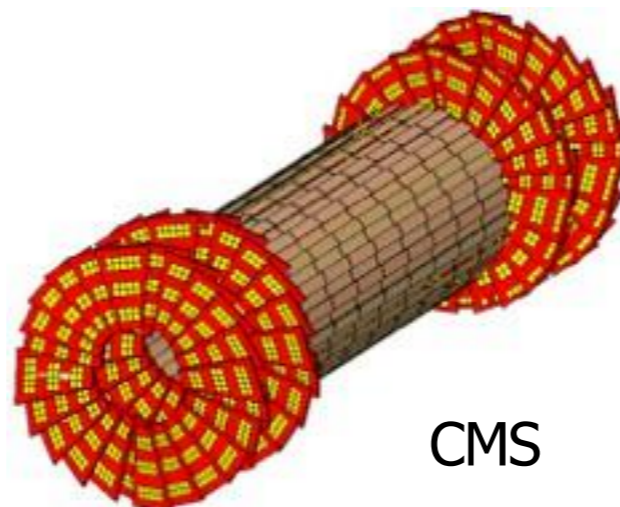

Space application

- **Satellites** (γ astrophysics, planetary sciences)
- Funding from ESA

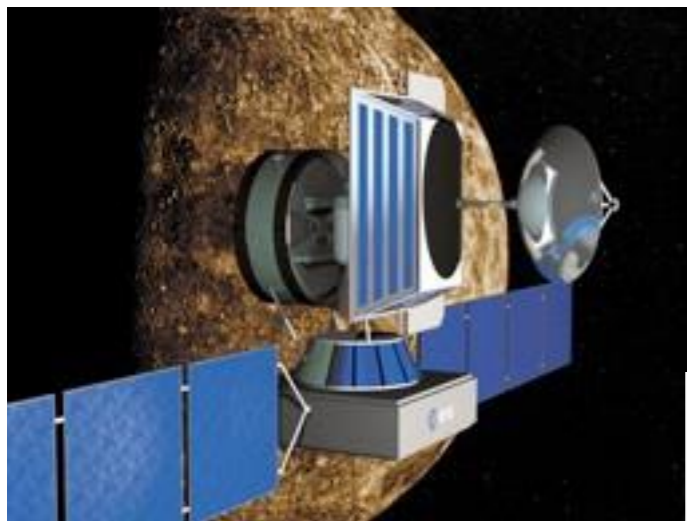

Typical telescope:
Tracker
Calorimeter
Anticoincidence

GLAST

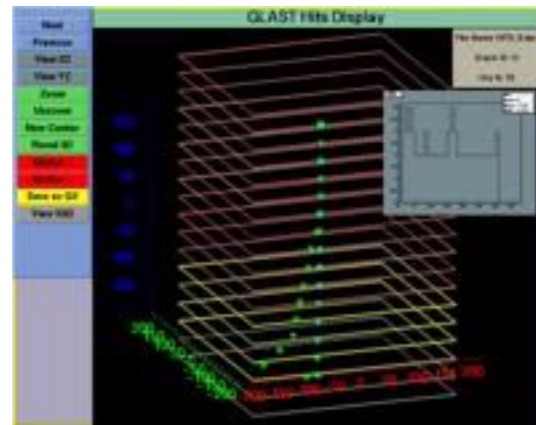

AGILE

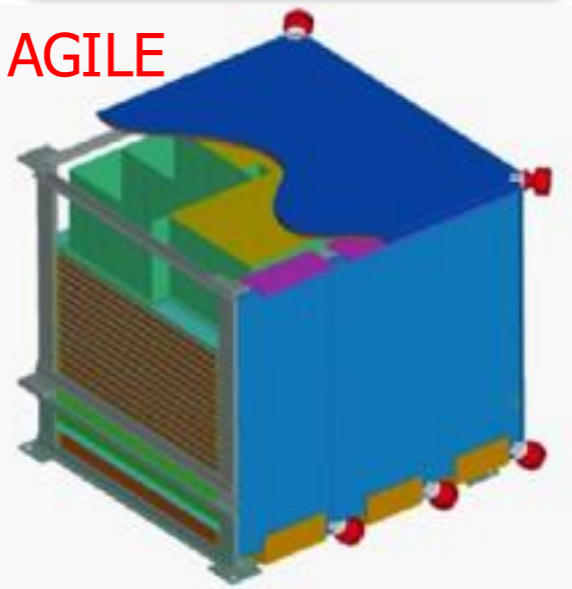

Medical Physics

- **Treatment planning** for **radiation therapy** systems
 - Goal: deliver dose to the tumor while **sparing** the **healthy tissues**
- Medical **imaging**
- **Radiation** fields from medical accelerators and **devices**

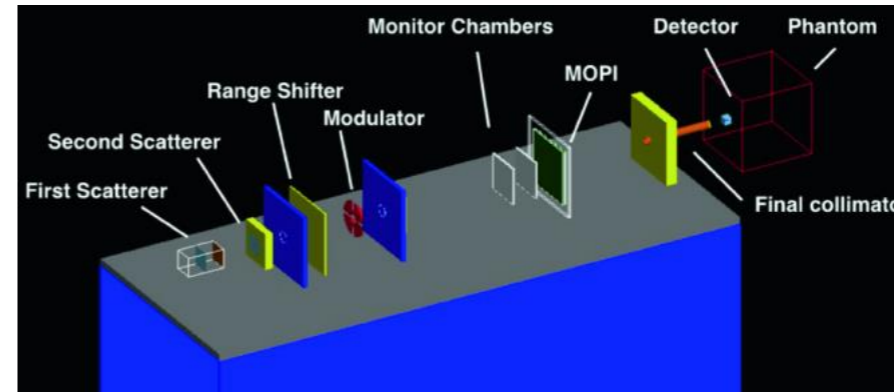

Hadron-therapy

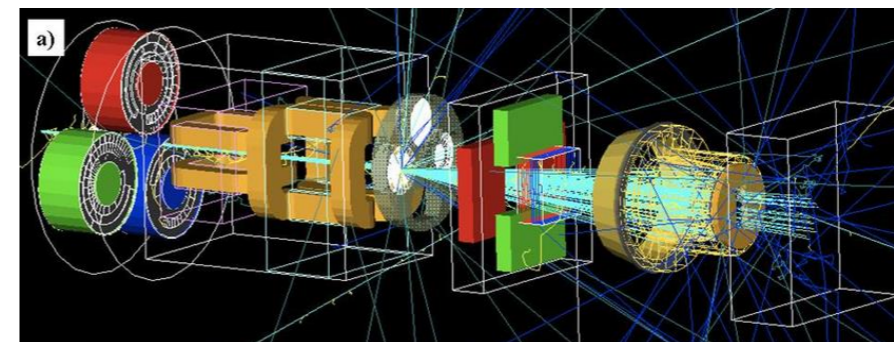

Proton-therapy

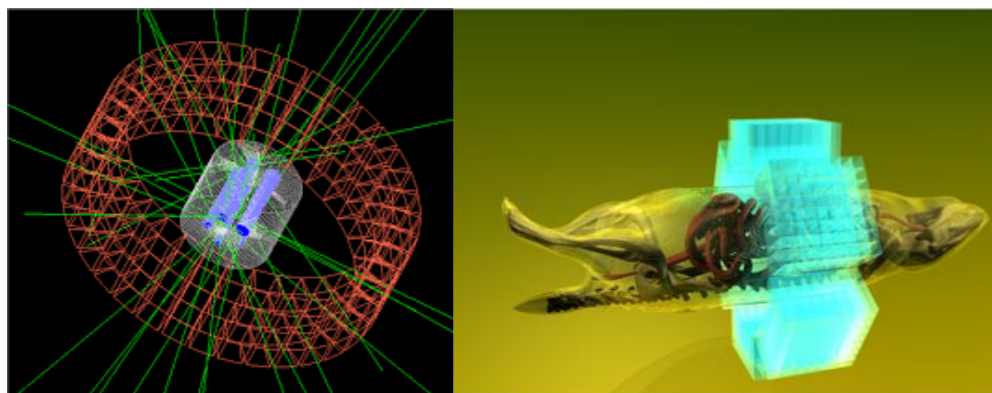

Preclinical PET System

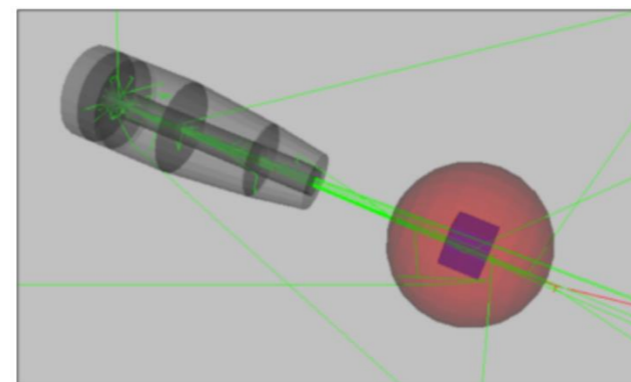

gamma-knife

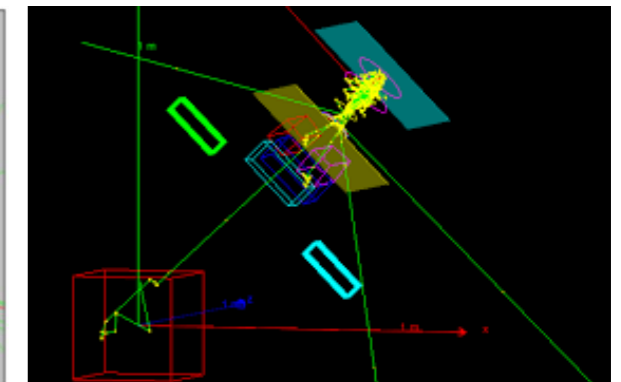

medical_linac

Project

Use Geant4 to simulate particle transport in radiotherapy and analyze how shielding influences the **doses** in on-axis and off-axis volumes

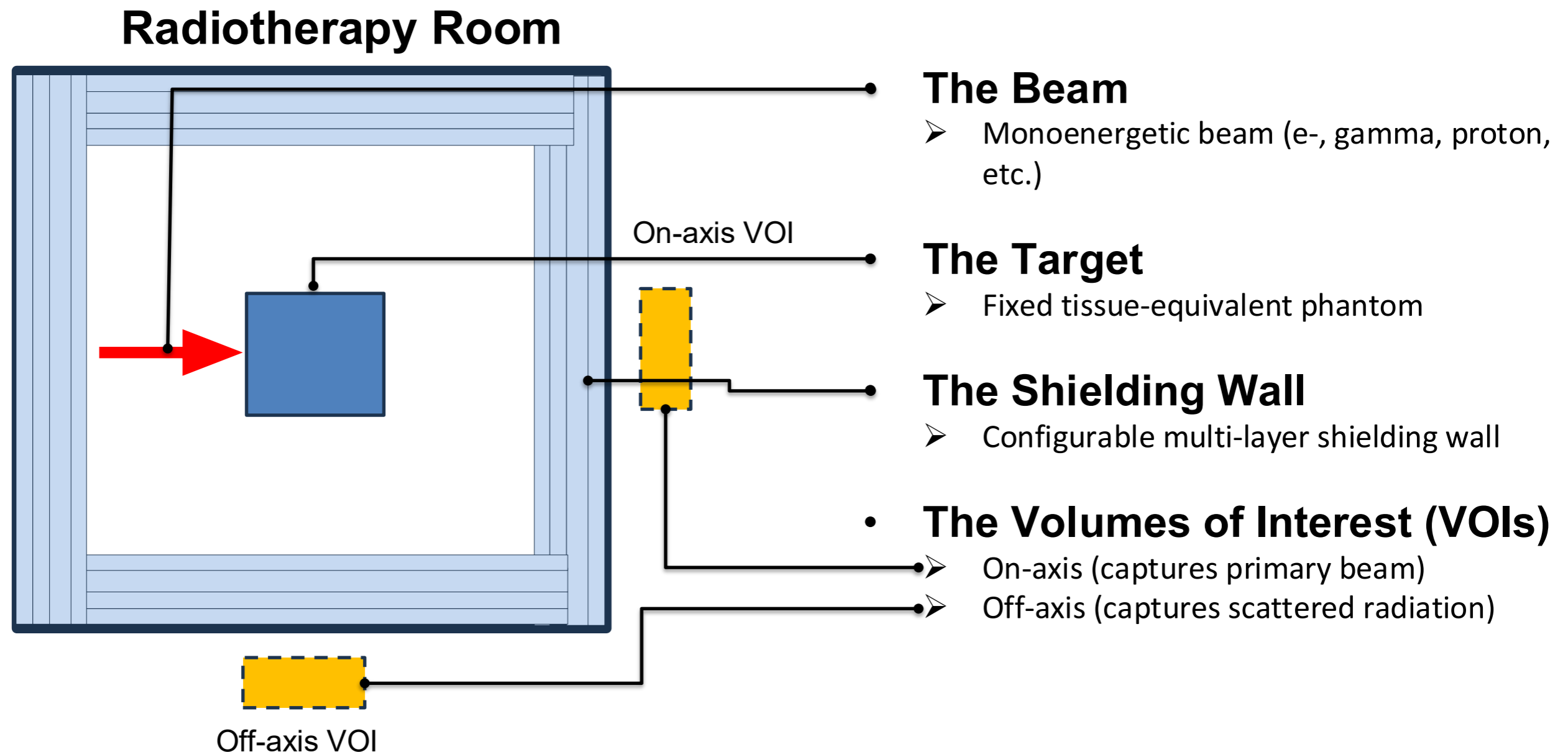

Workflow

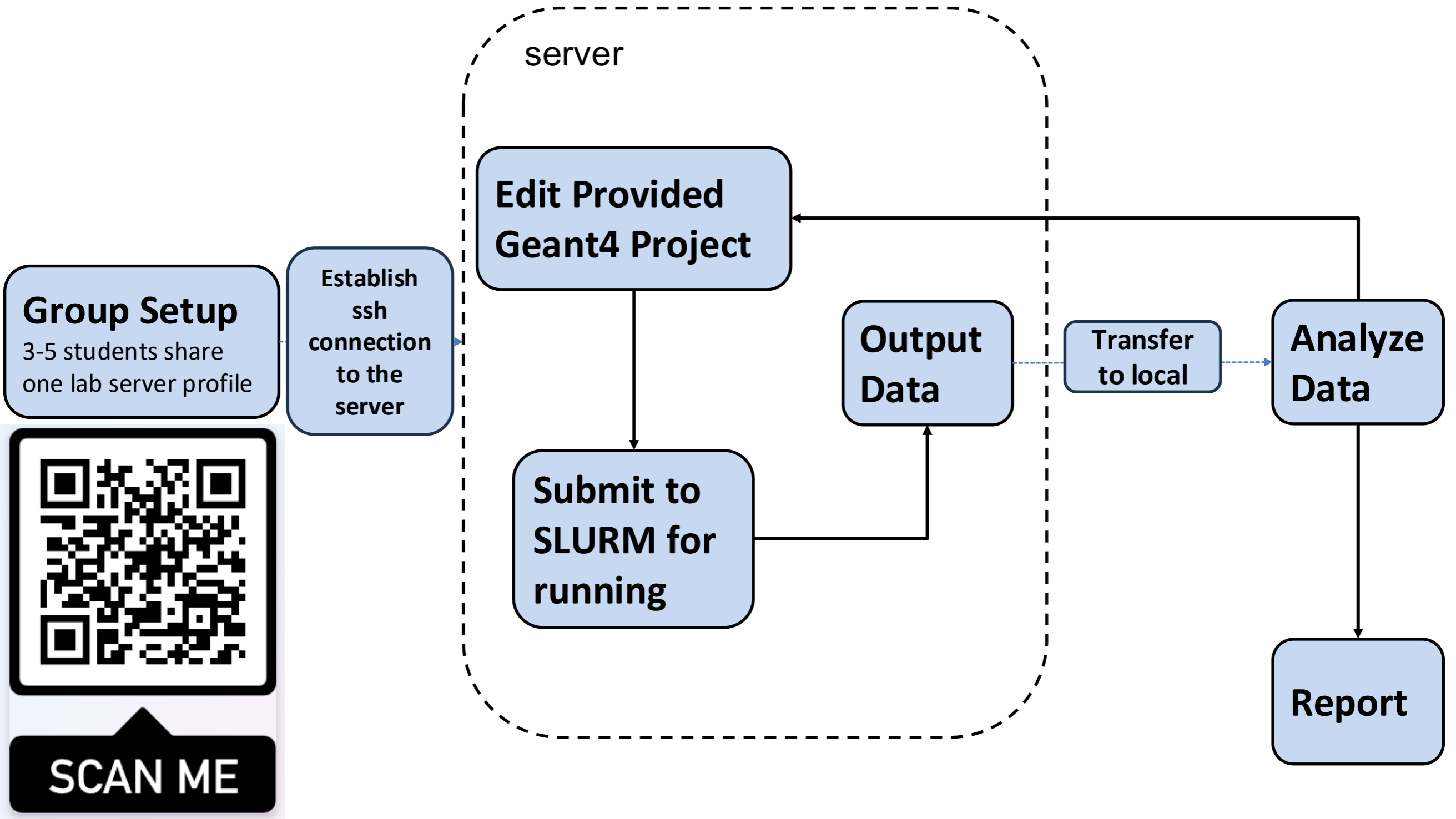

Configuration of the Physical Model

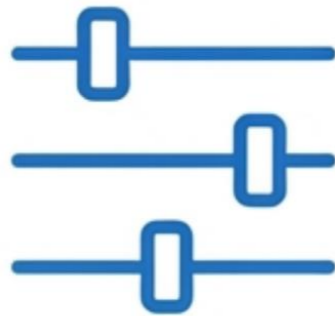

Adjustable via Macros

- Shielding material
- Shielding thickness
- Number of active shielding layers (1 to 5)
- Beam type (gamma, e-, protons)
- Energy bins
- Number of events



Fixed Source Code

- Base geometry layout
- Scoring logic
- C++ implementation

Expected Outputs from this Simulation Study

• For each VOI, please extract the following quantities from the output of GEANT 4:

1. Energy deposition in the VOI(s) from:

- Beta particles incident on the volume of interest (VOI)
- Photons
- Protons
- Neutrons

2. Total energy deposition in the VOI(s) from all particles.

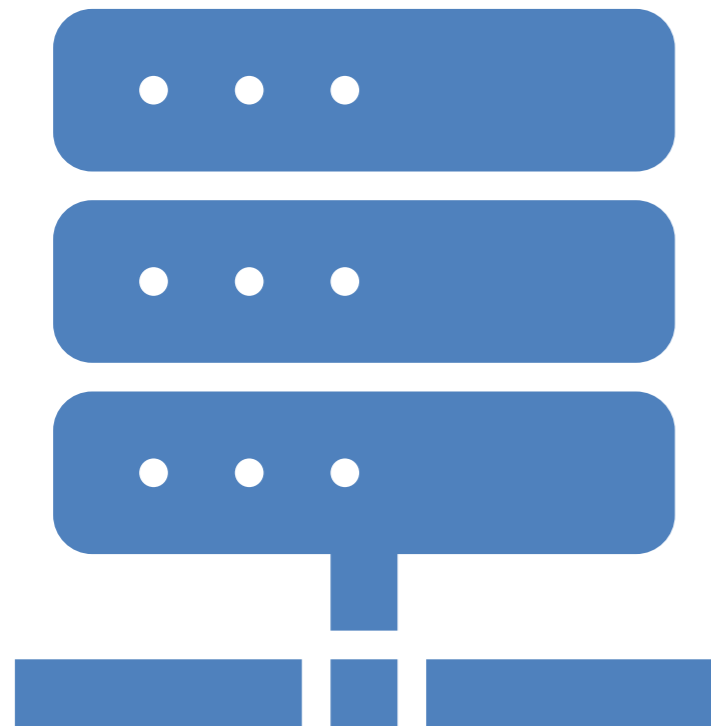

How to Access the Server through SSH?