

## ***Appendix C: Pipelining: Basic and Intermediate Concepts***

---

Key ideas and simple pipeline (Section C.1)

Hazards (Sections C.2 and C.3)

- Structural hazards

- Data hazards

- Control hazards

Exceptions (Section C.4)

Multicycle operations (Section C.5)

# Pipelining - Key Idea

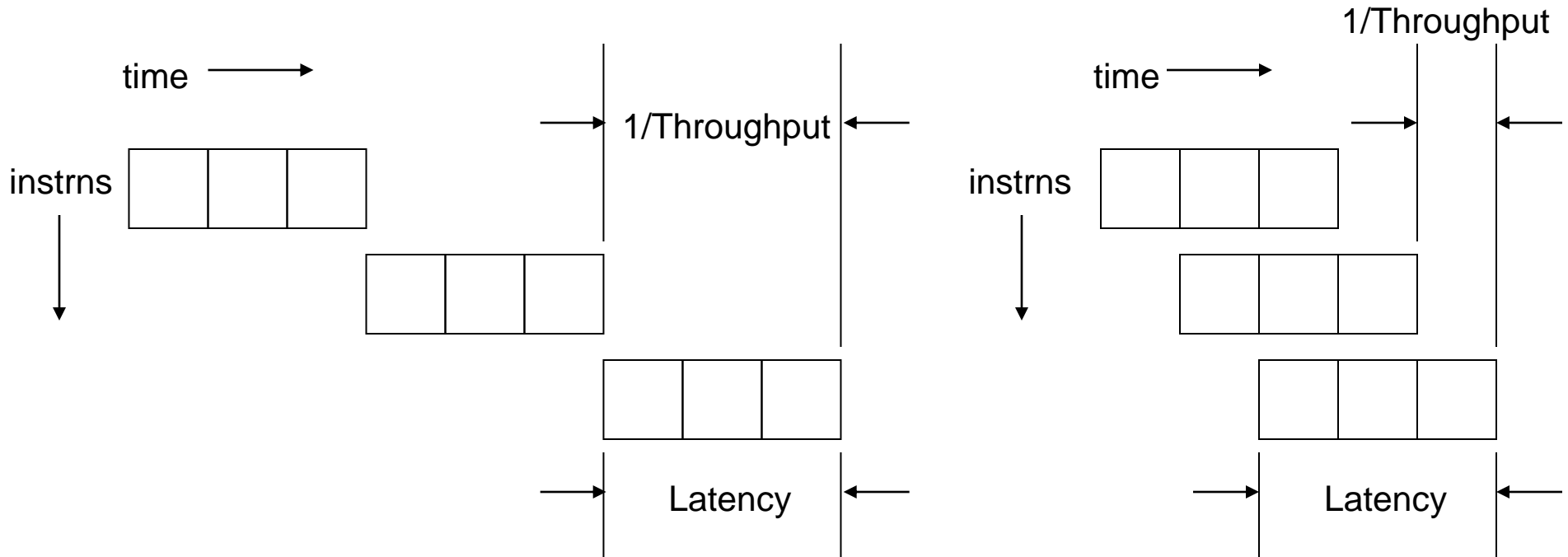

***Ideally,***

$$Time_{pipeline} = \frac{Time_{sequential}}{Pipeline\ Depth}$$

$$Speedup = \frac{Time_{sequential}}{Time_{pipeline}} = Pipeline\ Depth$$

# Practical Limit 1 – Unbalanced Stages

---

Consider an instruction that requires  $n$  stages

$s_1, s_2, \dots, s_n$ , taking time  $t_1, t_2, \dots, t_n$ .

Let  $T = \sum t_i$

Without pipelining

With an  $n$ -stage pipeline

Throughput =

Throughput =

Latency =

Latency =

Speedup

## *Practical Limit 2 - Overheads*

---

Let  $\Delta > 0$  be extra delay per stage

e.g., latches

$\Delta$  limits the useful depth of a pipeline.

With an  $n$  stage pipeline

$$\textit{Throughput} = \frac{1}{\Delta + \max t_i} < \frac{n}{T}$$

$$\textit{Latency} = n \times (\Delta + \max t_i) \geq n\Delta + T$$

$$\textit{Speedup} = \frac{\sum t_i}{\Delta + \max t_i} < n$$

## *Example*

---

Let  $t_{1,2,3} = 8, 12, 10$  ns and  $\Delta = 2$  ns

Throughput =

Latency =

Speedup =

## Practical Limit 3 - Hazards

---

$$\text{Pipeline Speedup} = \frac{\text{Time}_{\text{sequential}}}{\text{Time}_{\text{pipeline}}} = \frac{\text{CPI}_{\text{sequential}}}{\text{CPI}_{\text{pipeline}}} \times \frac{\text{Cycle Time}_{\text{sequential}}}{\text{Cycle Time}_{\text{pipeline}}}$$

If we ignore cycle time differences:

$$\text{CPI}_{\text{ideal-pipeline}} = \frac{\text{CPI}_{\text{sequential}}}{\text{Pipeline Depth}}$$

$$\text{Pipeline Speedup} = \frac{\text{CPI}_{\text{ideal-pipeline}} \times \text{Pipeline Depth}}{\text{CPI}_{\text{ideal-pipeline}} + \text{Pipeline stall cycles}}$$

# *Pipelining a Basic RISC ISA*

---

Assumptions:

Only loads and stores affect memory

Base register + immediate offset = effective address

ALU operations

Only access registers

Two sources – two registers, or register and immediate

Branches and jumps

Address = PC + offset

Comparison between a register and zero

***The last assumption is different from the 6<sup>th</sup> edition of the text and results in a slightly different pipeline. We will discuss reasons and implications in class.***

# A Simple Five Stage RISC Pipeline

---

## Pipeline Stages

IF – Instruction Fetch

ID – Instruction decode, register read, branch computation

EX – Execution and Effective Address

MEM – Memory Access

WB – Writeback

	1	2	3	4	5	6	7	8	9
i	IF	ID	EX	MEM	WB				
i+1		IF	ID	EX	MEM	WB			
i+2			IF	ID	EX	MEM	WB		
i+3				IF	ID	EX	MEM	WB	
i+4					IF	ID	EX	MEM	WB

Pipelining really isn't this simple



# A Naive Pipeline Implementation

Figure C.28  
of 5<sup>th</sup> edition

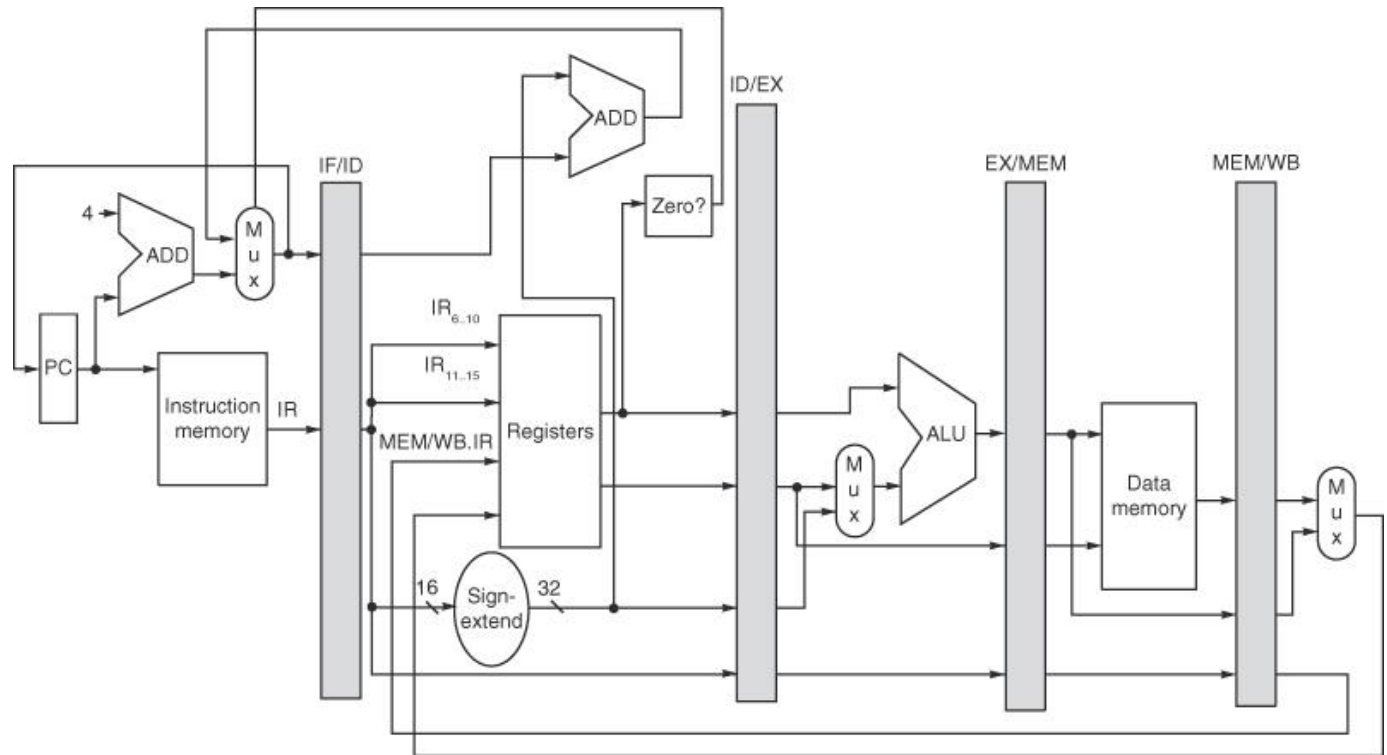

Copyright © 2011, Elsevier Inc. All rights Reserved.

Pipelining really isn't this simple

# *Hazards*

---

Hazards

Structural Hazards

Data Hazards

Control Hazards

# *Handling Hazards*

---

Pipeline interlock logic

    Detects hazard and takes appropriate action

Simplest solution: stall

    Increases CPI

    Decreases performance

Other solutions are harder, but have better performance

# Structural Hazards

---

When two *different* instructions want to use the *same* hardware resource in the *same* cycle

Stall (cause bubble)

- + Low cost, simple

- Increases CPI

- Use for rare events

- E.g., ??

Duplicate Resource

- + Good performance

- Increases cost (and maybe cycle time for interconnect)

- Use for cheap resources

- E.g., ALU and PC adder

## *Structural Hazards, cont.*

---

### Pipeline Resource

- + Good performance

- Often complex to do

- Use when simple to do

- E.g., write & read registers every cycle

Structural hazards are avoided if each instruction uses a resource

- At most once

- Always in the same pipeline stage

- For one cycle

- ( $\Rightarrow$  no cycle where two instructions use the same resource)

# Structural Hazard Example

---

Loads/stores (MEM) use same memory port as instrn fetches (IF)

30% of all instructions are loads and stores

Assume  $CPI_{old}$  is 1.5

	1	2	3	4	5	6	7	8	9	
i	IF	ID	EX	MEM	WB	<- a load				
i+1		IF	ID	EX	MEM	WB				
i+2			IF	ID	EX	MEM	WB			
i+3				**	IF	ID	EX	MEM	WB	
i+4						IF	ID	EX	MEM	WB

How much faster could a new machine with two memory ports be?

# Data Hazards

---

When two different instructions use the same location, it must appear as if instructions execute one at a time and in the specified order

```
i      ADD  r1, r2,  
i+1    SUB  r2, , r1  
i+2    OR   r1, --,
```

Read-After-Write (RAW, data-dependence)

A true dependence

**MOST IMPORTANT**

Write-After-Read (WAR, anti-dependence)

Write-After-Write (WAW, output-dependence)

NOT: Read-After-Read (RAR)

# Example Read-After-Write Hazards

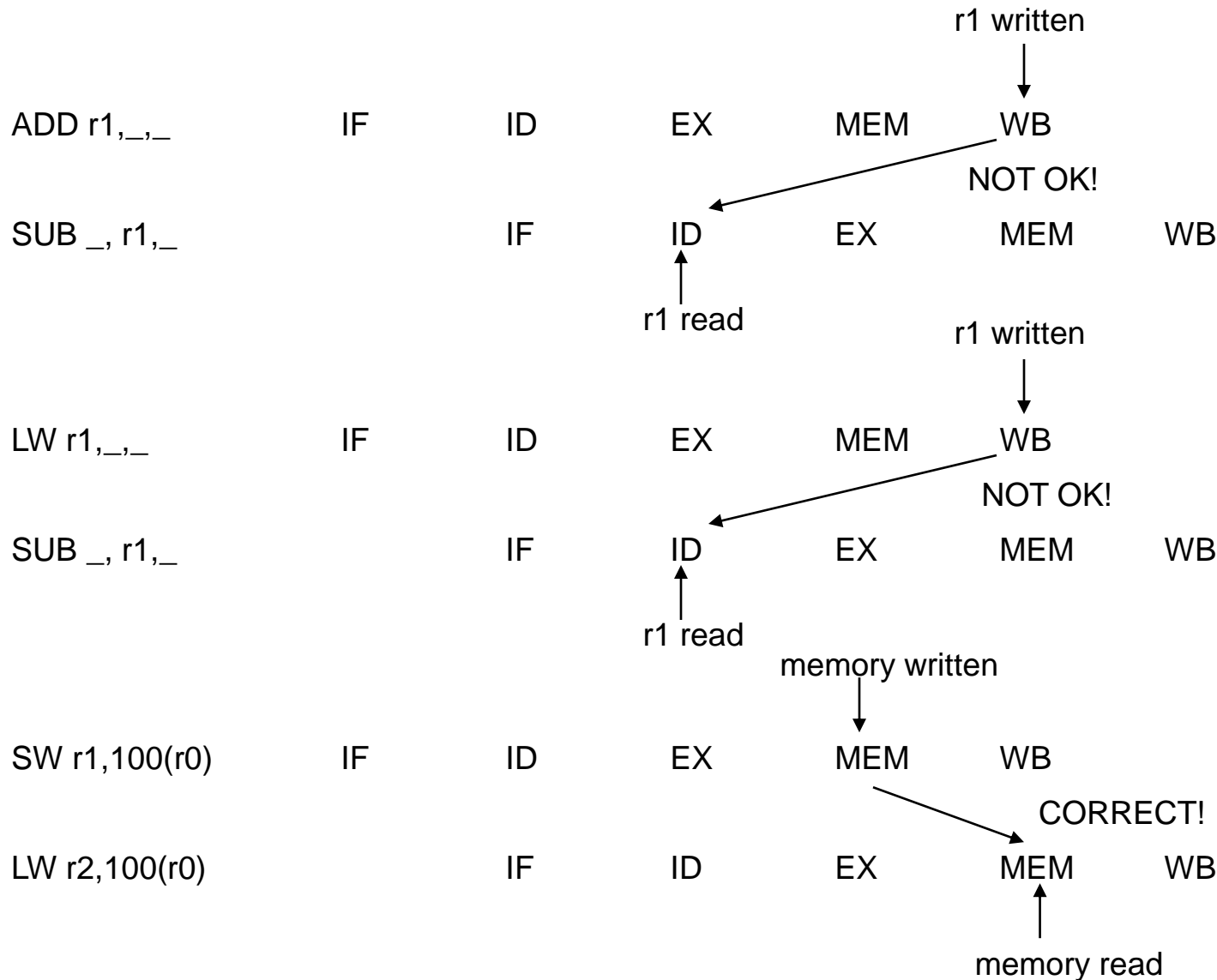

(Unless LW instrn is at address 100(r0))



# RAW Solutions

---

Solutions must first detect RAW, and then ...

Stall

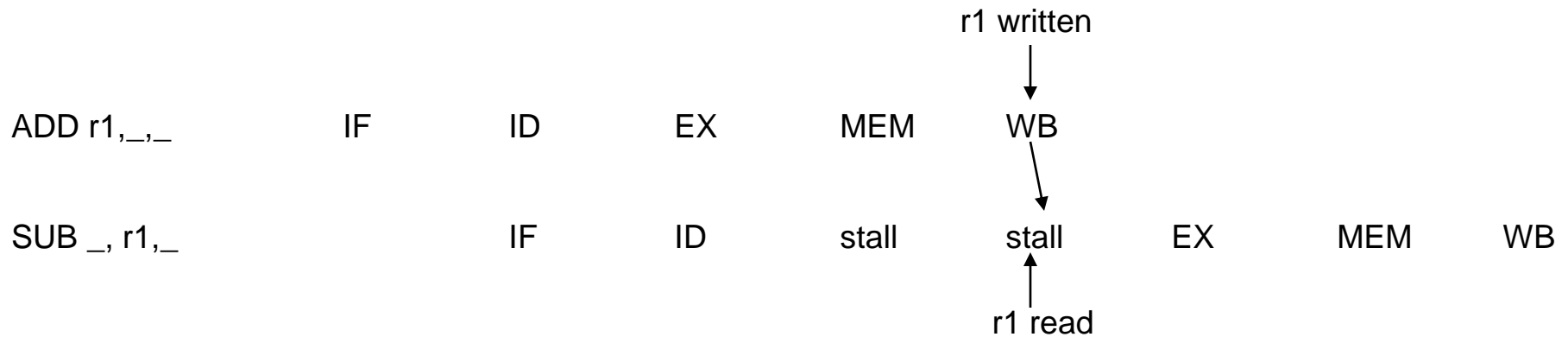

(Assumes registers written then read each cycle)

+ Low cost, simple

Increases CPI (plus 2 per stall in 5 stage pipeline)

Use for rare events

# RAW Solutions

---

## Bypass/Forward/ShortCircuit

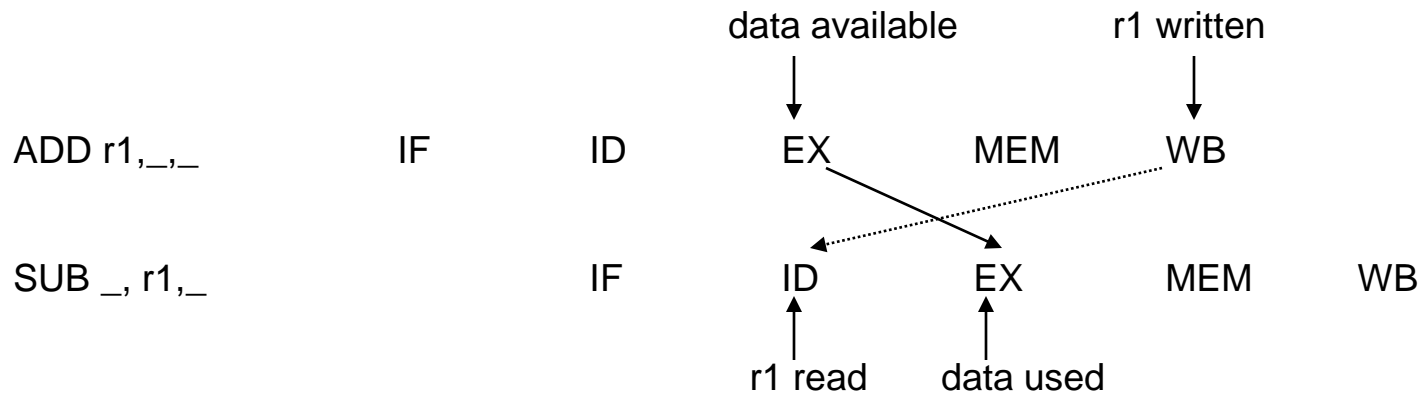

Use data before it is in register

+ Reduces (avoids) stalls

More complex

Critical for common RAW hazards

# Bypass, cont.

**Figure C.27**  
**5<sup>th</sup> edition**

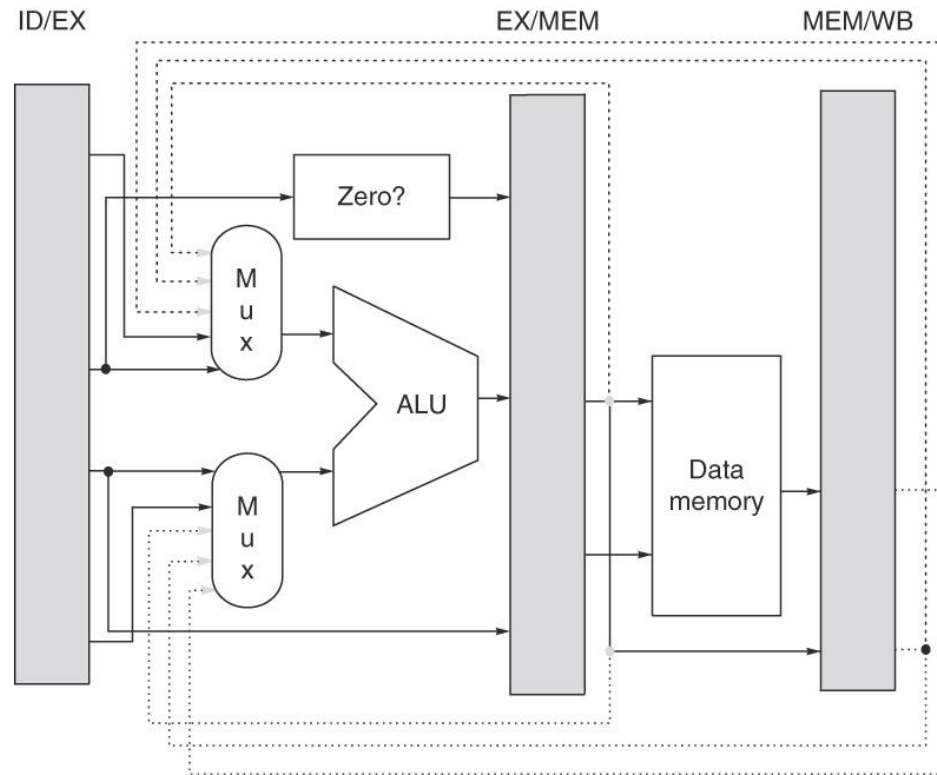

Copyright © 2011, Elsevier Inc. All rights Reserved.

Additional hardware

Muxes supply correct result to ALU

Additional control

Interlock logic must control muxes

# RAW Solutions, cont.

Hybrid solution sometimes required:

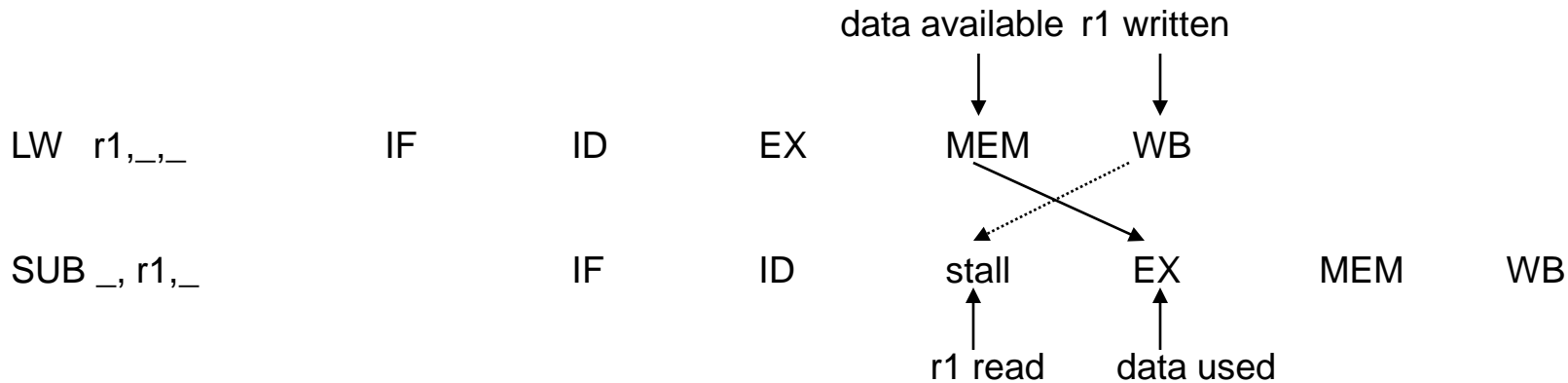

One cycle bubble if result of load used by next instruction

Pipeline scheduling at compile time

Moves instructions to eliminate stalls

# Pipeline Scheduling Example

---

Before:

```
a = b + c;  LW  Rb, b
             LW  Rc, c
             <- stall
             ADD Ra, Rb, Rc
             SW  a, Ra

d = e - f;  LW  Re, e
           LW  Rf, f
           <- stall
           SUB Rd, Re, Rf
           SW  d, Rd
```

After:

```
a = b + c;  LW  Rb, b
           LW  Rc, c
           LW  Re, e
           ADD Ra, Rb, Rc

d = e - f;  LW  Rf, f
           SW  a, Ra
           SUB Rd, Re, Rf
           SW  d, Rd
```

## *Other Data Hazards*

---

```
i      ADD r1,r2,  
i+1    SUB r2,,r1  
i+2    OR  r1,,
```

### Write-After-Read (WAR, anti-dependence)

```
i      MULT , (r2), r1 /* RX mult */  
i+1    LW   , (r1)+ /* autoincrement */
```

### Write-After-Write (WAW, output-dependence)

```
i      DIVF fr1, , /* slow */  
i+1  
i+2    ADDF fr1, , /* fast */
```

# Control Hazards

---

When an instruction affects which instructions are executed *next* --  
branches, jumps, calls

```
i      BEQZ r1,#8
i+1    SUB  ,,
      ...
i+8    OR   ,,
i+9    ADD  ,,
```

1	2	3	4	5	6	7	8	9
i	IF	ID	EX	MEM	WB			
i+1		IF (aborted)						
i+8			IF	ID	EX	MEM	WB	
i+9				IF	ID	EX	MEM	

Handling control hazards is very important

# *Handling Control Hazards*

---

## Branch Prediction

- Guess the direction of the branch

- Minimize penalty when right

- May increase penalty when wrong

## Techniques

- Static – At compile time

- Dynamic – At run time

## Static Techniques

- Predict NotTaken

- Predict Taken

- Delayed Branches

Dynamic techniques and more powerful static techniques later...



# Handling Control Hazards, cont.

---

Predict NOT-TAKEN Always

NotTaken:

	1	2	3	4	5	6	7	8
i	IF	ID	EX	MEM	WB			
i+1		IF	ID	EX	MEM	WB		
i+2			IF	ID	EX	MEM	WB	
i+3				IF	ID	EX	MEM	WB

Taken:

	1	2	3	4	5	6	7	8
i	IF	ID	EX	MEM	WB			
i+1		IF	(aborted)					
i+8			IF	ID	EX	MEM	WB	
i+9				IF	ID	EX	MEM	WB

Don't change machine state until branch outcome is known

Basic pipeline: State always changes late (WB)

## Handling Control Hazards, cont.

---

Predict TAKEN Always

	1	2	3	4	5	6	7	8
<i>i</i>	IF	ID	EX	MEM	WB			
<i>i</i> +8		'IF'	ID	EX	MEM	WB		
<i>i</i> +9			IF	ID	EX	MEM	WB	
<i>i</i> +10				IF	ID	EX	MEM	WB

Must know what address to fetch at BEFORE branch is decoded

Not practical for our basic pipeline

## *Handling Control Hazards, cont.*

---

Delayed branch

Execute next instruction regardless (of whether branch is taken)

What do we execute in the DELAY SLOT?

# *Delay Slots*

---

Fill from before branch

When:

Helps:

Fill from target

When:

Helps:

Fill from fall through

When:

Helps:

## *Delay Slots (Cont.)*

---

Cancelling or nullifying branch

Instruction includes direction of prediction

Delay instruction squashed if wrong prediction

Allows second and third case of previous slide to be more aggressive

# Comparison of Branch Schemes

---

Suppose 14% of all instructions are branches

Suppose 65% of all branches are taken

Suppose 50% of delay slots usefully filled

CPIpenalty = % branches ×

(% Taken × Taken-Penalty + % Not-Taken × Not-Taken penalty)

Branch Scheme	Taken Penalty	Not-Taken Penalty	CPI Penalty
Basic Branch	1	1	.14
Not-Taken	1	0	.09
Taken0	0	1	.05
Taken1	1	1	.14
Delayed Branch	.5	.5	.07

# *Real Processors*

---

MIPS R4000: 3 cycle branch penalty

First cycle: cancelling delayed branch (cancel if not taken)

Next two cycles: Predict not taken

Recent architectures:

Because of deeper pipelines, delayed branches not very useful

Processors rely more on hardware prediction (will see later) or  
may include both delayed and nondelayed branches

# *Interrupts*

---

Interrupts (a.k.a. faults, exceptions, traps) often require

- Surprise jump

- Linking of return address

- Saving of PSW (including CCs)

- State change (e.g., to kernel mode)

Some examples

- Arithmetic overflow

- I/O device request

- O.S. call

- Page fault

Make pipelining hard



# *One Classification of Interrupts*

---

## 1a. Synchronous

function of program and memory state

(e.g., arithmetic overflow, page fault)

## 1b. Asynchronous

external device or hardware malfunction

(printer ready, bus error)

# *Handling Interrupts*

---

Precise Interrupts (Sequential Semantics)

Complete instrns before offending one

Squash (effects of) instrns after

Save PC

Force trap instrn into IF

Must handle simultaneous interrupts

IF –

ID –

EX –

MEM –

WB –

Which interrupt should be handled first?

# Interrupts, cont.

---

## Example: Data Page Fault

	1	2	3	4	5	6	7	8
i	IF	ID	EX	MEM	WB			
i+1		IF	ID	EX	MEM	WB	← page fault (MEM)	
i+2			IF	ID	EX	MEM	WB	← squash
i+3				IF	ID	EX	MEM	WB ← squash
i+4					IF	ID	EX	MEM WB ← squash
i+5				trap	→	IF	ID	EX MEM WB
i+6				trap handler	→	IF	ID	EX MEM WB

Preceding instruction already complete

Squash succeeding instructions

Prevent from modifying state

'Trap' instruction jumps to trap handler

Hardware saves PC in IAR

Trap handler must save IAR

# Interrupts, cont.

---

## Example: Arithmetic Exception

	1	2	3	4	5	6	7	8	
i	IF	ID	EX	MEM	WB				
i+1		IF	ID	EX	MEM	WB			
i+2			IF	ID	EX	MEM	WB	← Exception (EX)	
i+3				IF	ID	EX	MEM	WB ← squash	
i+4					IF	ID	EX	MEM	WB ← squash
i+5				trap →	IF	ID	EX	MEM	WB
i+6				trap handler →	IF	ID	EX	MEM	WB

Let preceding instructions complete

Squash succeeding instruction

# Interrupts, cont.

---

## Example: Illegal Opcode

	1	2	3	4	5	6	7	8
i	IF	ID	EX	MEM	WB			
i+1		IF	ID	EX	MEM	WB		
i+2			IF	ID	EX	MEM	WB	
i+3				IF	ID	EX	MEM	WB ← ill. op (ID)
i+4					IF	ID	EX	MEM WB ← squash
i+5				trap →	IF	ID	EX	MEM WB
i+6				trap handler →	IF	ID	EX	MEM WB

Let preceding instructions complete

Squash succeeding instruction

# Interrupts, cont.

---

## Example: Out-of-order Interrupts

	1	2	3	4	5	6	7	8
i	IF	ID	EX	MEM	WB	<-	page fault (MEM)	
i+1		IF	ID	EX	MEM	WB	<-	page fault (IF)
i+2			IF	ID	EX	MEM	WB	
i+3				IF	ID	EX	MEM	WB

Which page fault should we take?

For precise interrupts – Post interrupts on a status vector associated with instruction, disable later writes in pipeline

- Check interrupt bit on entering WB

- Longer latency

For imprecise interrupts – Handle immediately

- Interrupts may occur in different order than on a sequential machine

- May cause implementation headaches

## *Interrupts, cont.*

---

Other complications

- Odd bits of state (e.g., CCs)

- Earlywrites (e.g., autoincrement)

- Outoforder execution

Interrupts come at random times

- The frequent case isn't everything

- The rare case **MUST** work correctly

# *Multicycle Operations*

---

Not all operations complete in one cycle

Floating point arithmetic is inherently slower than integer arithmetic

2 to 4 cycles for multiply or add

20 to 50 cycles for divide

Extend basic 5-stage pipeline

EX stage may repeat multiple times

Multiple function units

Not pipelined for now



# *Handling Multicycle Operations*

---

## Four Functional Units

EX: Integer unit

E\*: FP/integer multiplier

E+: FP adder

E/: FP/integer divider

## Assume

EX takes one cycle & all FP units take 4

Separate integer and FP registers

All FP arithmetic from FP registers

## Worry about

Structural hazards

RAW hazards & forwarding

WAR & WAW between integer & FP ops

# Simple Multicycle Example

---

	1	2	3	4	5	6	7	8	9	10	11
int	IF	ID	EX	MEM	WB						
fp*		IF	ID	E*	E*	E*	E*	MEM	WB		
int			IF	ID	EX	MEM	WB?	(1)			
fp/				IF	ID	E/	E/	E/	E/	MEM	WB
int					IF	ID	EX	**	MEM	WB	(2)
fp/				(3)	IF	ID	**	**	E/	E/	
int					(4)	IF	**	**	ID	EX	

## Notes

- (1) WAW possible only if?
- (2) Stall forced by?
- (3) Stall forced by?
- (4) Stall forced by?

# ***FP Instruction Issue***

---

Check for RAW data hazard (in ID)

Wait until source registers are not used as destinations by instructions in EX that will not be available when needed

Check for forwarding

Bypass data from other stages, if necessary

Check for structural hazard in function unit

Wait until function unit is free (in ID)

Check for structural hazard in MEM / WB

Instructions stall in ID

Instructions stall before MEM

Static priority (e.g., FU with longest latency)

## *FP Instruction Issue (Cont.)*

---

Check for WAW hazards

```
DIVF F0, F2, F4
```

```
SUBF F0, F8, F10
```

SUBF completes first

(1) Stall SUBF

(2) Abort DIVF's WB

WAR hazards?

# *More Multicycle Operations*

---

## Problems with Interrupts

```
DIVF F0, F2, F4
```

```
ADDF F2, F8, F10
```

```
SUBF F6, F4, F10
```

ADDF and SUBF complete before DIVF

Out-of-order completion

Possible imprecise interrupt

What happens if DIVF generates an exception after ADDF and SUBF complete??

We'll discuss solutions later